

FR-E700

Frequency Inverter

Instruction Manual

FR-E720S EC
FR-E740 EC

**Instruction Manual
Inverter FR-E700 EC
Art. no.: 213994**

| Version | | Changes / Additions / Corrections | |
|----------------|-------------------|--|--|
| A | 11/2007 pdp | — | |
| B | 08/2008 pdp | General | Description of the 3-phase frequency inverter for 400 V Expansion of performance classes through the frequency inverter FR-E740-230 and 300 Revision and correction of individual sections |
| C | 09/2009 pdp – akl | General Section 7.6 | Expansion of the range of models by the inverters FR-E720S for connection to a single-phase power supply Check first when you have troubles |
| C1 | 09/2010 akl | Page 3-30 Page 3-32 | Thermal relay type name |
| D | 03/2011 akl | Chapter 3 | Replacement: DC reactor FR-HEL -> FFR-HEL-(H)-E |

Thank you for choosing this Mitsubishi inverter.

This instruction manual provides instructions for advanced use of the FR-E700 series inverters. Incorrect handling might cause an unexpected fault. Before using the inverter, always read this instruction manual to use the equipment to its optimum.

Safety instructions

Do not attempt to install, operate, maintain or inspect the inverter until you have read through this instruction manual carefully and can use the equipment correctly. Do not use the inverter until you have a full knowledge of the equipment, safety information and instructions. In this instruction manual, the safety instruction levels are classified into "WARNING" and "CAUTION".



WARNING:

Assumes that incorrect handling may cause hazardous conditions, resulting in death or severe injury.



CAUTION:

Assumes that incorrect handling may cause hazardous conditions, resulting in medium or slight injury, or may cause physical damage only.

Note that even the CAUTION level may lead to a serious consequence according to conditions. Please follow strictly the instructions of both levels because they are important to personnel safety.

Electric Shock Prevention



WARNING:

- *While power is on or when the inverter is running, do not open the front cover. Otherwise you may get an electric shock.*
- *Do not run the inverter with the front cover removed. Otherwise, you may access the exposed high-voltage terminals or the charging part of the circuitry and get an electric shock.*
- *Even if power is off, do not remove the front cover except for wiring or periodic inspection. You may access the charged inverter circuits and get an electric shock.*
- *Before starting wiring or inspection, check to make sure that the operation panel indicator is off, wait for at least 10 minutes after the power supply has been switched off, and check that there are no residual voltage using a tester or the like. The capacitor is charged with high voltage for some time after power off and it is dangerous.*
- *This inverter must be earthed. Earthing must conform to the requirements of national and local safety regulations and electrical codes. (JIS, NEC section 250, IEC 536 class 1 and other applicable standards)
Use a neutral-point earthed (grounded) power supply for 400V class inverter in compliance with EN standard.*
- *Any person who is involved in the wiring or inspection of this equipment should be fully competent to do the work.*
- *Always install the inverter before wiring. Otherwise, you may get an electric shock or be injured.*
- *Perform setting dial and key operations with dry hands to prevent an electric shock. Otherwise you may get an electric shock.*
- *Do not subject the cables to scratches, excessive stress, heavy loads or pinching. Otherwise you may get an electric shock.*
- *Do not replace the cooling fan while power is on. It is dangerous to replace the cooling fan while power is on.*
- *Do not touch the printed circuit board with wet hands. You may get an electric shock.*
- *When measuring the main circuit capacitor capacity, the DC voltage is applied to the motor for 1s at powering off. Never touch the motor terminal, etc. right after powering off to prevent an electric shock.*

Fire Prevention



CAUTION:

- *Mount the inverter to incombustible material. Install the inverter on a nonflammable wall without holes (so that nobody can touch the inverter heatsink on the rear side, etc.). Mounting it to or near combustible material can cause a fire.*
- *If the inverter has become faulty, switch off the inverter power. A continuous flow of large current could cause a fire.*
- *When using a brake resistor, make up a sequence that will turn off power when an alarm signal is output. Otherwise, the brake resistor may excessively overheat due to damage of the brake transistor and such, causing a fire.*
- *Do not connect a resistor directly to the DC terminals +, -. This could cause a fire and destroy the inverter. The surface temperature of braking resistors can far exceed 100°C for brief periods. Make sure that there is adequate protection against accidental contact and a safe distance is maintained to other units and system parts.*

Injury Prevention



CAUTION:

- *Apply only the voltage specified in the instruction manual to each terminal. Otherwise, burst, damage, etc. may occur.*
- *Ensure that the cables are connected to the correct terminals. Otherwise, burst, damage, etc. may occur.*
- *Always make sure that polarity is correct to prevent damage, etc. Otherwise, burst, damage, etc. may occur.*
- *While power is on or for some time after power-off, do not touch the inverter as it is hot and you may get burnt.*

Additional Instructions

Also note the following points to prevent an accidental failure, injury, electric shock, etc.

Transport und Installation



CAUTION:

- **Transport the product using the correct method that corresponds to the weight. Failure to observe this could lead to injuries.**
- **Do not stack the inverter boxes higher than the number recommended.**
- **Ensure that installation position and material can withstand the weight of the inverter. Install according to the information in the instruction manual.**
- **Do not install or operate the inverter if it is damaged or has parts missing. This can result in breakdowns.**
- **When carrying the inverter, do not hold it by the front cover or setting dial; it may fall off or fail.**
- **Do not stand or rest heavy objects on the product.**
- **Check the inverter mounting orientation is correct.**
- **Prevent other conductive bodies such as screws and metal fragments or other flammable substance such as oil from entering the inverter.**
- **As the inverter is a precision instrument, do not drop or subject it to impact.**
- **Use the inverter under the following environmental conditions. Otherwise, the inverter may be damaged.**

| Operating Condition | Specifications |
|---------------------|--|
| Ambient temperature | -10°C to +50°C (non-freezing) |
| Ambient humidity | 90% RH or less (non-condensing) |
| Storage temperature | -20°C to +65°C ^① |
| Atmosphere | Indoors (free from corrosive gas, flammable gas, oil mist, dust and dirt) |
| Altitude | Maximum 1000m above sea level for standard operation. After that derate by 3% for every extra 500m up to 2500m (91%) |
| Vibration | 5.9m/s ² or less at 10 to 55Hz (directions of X, Y, Z axes) |

^① Temperature applicable for a short time, e.g. in transit.

Wiring



CAUTION:

- **Do not install assemblies or components (e. g. power factor correction capacitors) on the inverter output side, which are not approved from Mitsubishi.**
- **The direction of rotation of the motor corresponds to the direction of rotation commands (STF/STR) only if the phase sequence (U, V, W) is maintained.**

Trial run



CAUTION:

- *Before starting operation, confirm and adjust the parameters. A failure to do so may cause some machines to make unexpected motions.*

Operation



WARNING:

- *When you have chosen the retry function, stay away from the equipment as it will restart suddenly after an alarm stop.*
- *Since pressing the STOP/RESET-key may not stop output depending on the function setting status, provide a circuit and switch separately to make an emergency stop (power off, mechanical brake operation for emergency stop, etc).*
- *Make sure that the start signal is off before resetting the inverter alarm. A failure to do so may restart the motor suddenly.*
- *The load used should be a three-phase induction motor only. Connection of any other electrical equipment to the inverter output may damage the equipment.*
- *Do not modify the equipment.*
- *Do not perform parts removal which is not instructed in this manual. Doing so may lead to fault or damage of the inverter.*



CAUTION:

- *The electronic thermal relay function does not guarantee protection of the motor from overheating. It is recommended to install both an external thermal and PTC thermistor for overheat protection.*
- *Do not use a magnetic contactor on the inverter input for frequent starting/stopping of the inverter. Otherwise, the life of the inverter decreases.*
- *Use a noise filter to reduce the effect of electromagnetic interference and follow the accepted EMC procedures for proper installation of frequency inverters. Otherwise nearby electronic equipment may be affected.*
- *Take appropriate measures regarding harmonics. Otherwise this can endanger compensation systems or overload generators.*
- *Use a motor designed for inverter operation. (The stress for motor windings is bigger than in line power supply).*
- *When parameter clear or all clear is performed, set again the required parameters before starting operations. Each parameter returns to the initial value.*
- *The inverter can be easily set for high-speed operation. Before changing its setting, fully examine the performances of the motor and machine.*
- *The DC braking function of the frequency inverter is not designed to continuously hold a load. Use an electro-mechanical holding brake on the motor for this purpose.*
- *Before running an inverter which had been stored for a long period, always perform inspection and test operation.*
- *For prevention of damage due to static electricity, touch nearby metal before touching this product to eliminate static electricity from your body.*

Emergency stop



CAUTION:

- *Provide a safety backup such as an emergency brake which will prevent the machine and equipment from hazardous conditions if the inverter fails.*
- *When the breaker on the inverter primary side trips, check for the wiring fault (short circuit), damage to internal parts of the inverter, etc. Identify the cause of the trip, then remove the cause and power on the breaker.*
- *When the protective function is activated (i. e. the frequency inverter switches off with an error message), take the corresponding corrective action as described in the inverter manual, then reset the inverter, and resume operation.*

Maintenance, inspection and parts replacement



CAUTION:

- *Do not carry out a megger (insulation resistance) test on the control circuit of the inverter. It will cause a failure.*

Disposing the inverter



CAUTION:

- *Treat as industrial waste.*

General instructions

Many of the diagrams and drawings in instruction manuals show the inverter without a cover, or partially open. Never run the inverter in this status. Always replace the cover and follow this instruction manual when operating the inverter.

Contents

| | | |
|----------|--|------|
| 1 | Product checking and part identification | |
| 1.1 | Inverter type | 1-1 |
| 1.2 | Description of the Case | 1-2 |
| 1.2.1 | Accessory | 1-3 |
| 2 | Installation | |
| 2.1 | Removal and reinstallation of the front cover | 2-1 |
| 2.1.1 | FR-E720S and FR-E740-016 to FR-E740-170 | 2-1 |
| 2.1.2 | FR-E740-230 and FR-E740-300 | 2-2 |
| 2.2 | Removal and reinstallation of the wiring cover | 2-4 |
| 2.3 | Mounting | 2-5 |
| 2.4 | Enclosure design | 2-7 |
| 2.4.1 | Inverter installation environment | 2-7 |
| 2.4.2 | Inverter placement | 2-11 |
| 3 | Wiring | |
| 3.1 | Inverter and peripheral devices | 3-1 |
| 3.1.1 | Peripheral devices | 3-3 |
| 3.2 | Terminal connection diagramm | 3-4 |
| 3.3 | Main circuit connection | 3-6 |
| 3.3.1 | Specification of main circuit terminal | 3-6 |
| 3.3.2 | Terminal layout and wiring | 3-7 |
| 3.4 | Control circuit specifications | 3-14 |
| 3.4.1 | Control circuit terminals | 3-17 |
| 3.4.2 | Wiring instructions | 3-19 |
| 3.4.3 | Changing the control logic | 3-20 |

| | | |
|-------|--|------|
| 3.5 | PU connector | 3-23 |
| 3.5.1 | Connecting the parameter unit using a connection cable | 3-23 |
| 3.5.2 | RS-485 communication | 3-24 |
| 3.6 | USB connector | 3-25 |
| 3.7 | Connection of stand-alone option units | 3-26 |
| 3.7.1 | Magnetic contactors (MC) | 3-26 |
| 3.7.2 | Connection of a dedicated external brake resistor FR-ABR and MRS (FR-E720S-030 or more, FR-E740-016 or more) | 3-28 |
| 3.7.3 | Connection of a brake unit FR-BU2 | 3-32 |
| 3.7.4 | Connection of the high power factor converter FR-HC | 3-35 |
| 3.7.5 | Connection of the power regeneration common converter FR-CV | 3-36 |
| 3.7.6 | Connection of the power improving DC reactor FFR-HEL-(H)-E | 3-37 |
| 3.7.7 | Installation of a reactor | 3-37 |
| 3.8 | Electromagnetic compatibility (EMC) | 3-38 |
| 3.8.1 | Leakage currents and countermeasures | 3-38 |
| 3.8.2 | Inverter-generated noises and their reduction techniques | 3-42 |
| 3.8.3 | Power supply harmonics | 3-45 |
| 3.8.4 | Inverter-driven 400V class motor | 3-46 |

4 Operation

| | | |
|--------|---|------|
| 4.1 | Precautions for use of the inverter | 4-1 |
| 4.1.1 | Failsafe of the system which uses the inverter | 4-3 |
| 4.2 | Drive the motor | 4-6 |
| 4.3 | Operation panel | 4-7 |
| 4.3.1 | Parts of the operation panel | 4-7 |
| 4.3.2 | Basic operation (factory setting) | 4-9 |
| 4.3.3 | Easy operation mode setting (easy setting mode) | 4-10 |
| 4.3.4 | Operation lock | 4-12 |
| 4.3.5 | Monitoring of output current and output voltage | 4-14 |
| 4.3.6 | First priority monitor | 4-14 |
| 4.3.7 | Digital dial push | 4-14 |
| 4.3.8 | Change the parameter setting value | 4-15 |
| 4.3.9 | Parameter clear/All Parameter clear | 4-16 |
| 4.3.10 | Initial value change list | 4-17 |

| | | |
|----------|--|------|
| 5 | Basic settings | |
| 5.1 | Simple mode parameter list | 5-1 |
| 5.1.1 | Overheat protection of the motor by the inverter | 5-2 |
| 5.1.2 | When the rated motor frequency is 60Hz (Pr. 3) | 5-4 |
| 5.1.3 | Increase the starting torque (Pr. 0) | 5-5 |
| 5.1.4 | Limit the maximum and minimum output frequency (Pr. 1, Pr. 2) | 5-7 |
| 5.1.5 | Change the acceleration/deceleration time (Pr. 7, Pr. 8) | 5-9 |
| 5.1.6 | Operation mode (Pr. 79) | 5-11 |
| 5.1.7 | Large starting torque and low speed torque are necessary (Advance magnetic flux control, general-purpose magnetic flux vector control) (Pr. 71, Pr. 80, Pr. 81, Pr. 800) | 5-12 |
| 5.1.8 | To exhibit the best performance of the motor performance (offline auto tuning) (Pr. 9, Pr. 71, Pr. 83, Pr. 84, Pr. 96) | 5-15 |
| 5.2 | PU operation mode | 5-20 |
| 5.2.1 | Set the set frequency to operate | 5-21 |
| 5.2.2 | Use the digital dial like a potentiometer to perform operation | 5-23 |
| 5.2.3 | Use switches to give the frequency command (multi-speed setting) | 5-24 |
| 5.2.4 | Perform frequency setting by analog voltage input | 5-26 |
| 5.2.5 | Perform frequency setting by analog current input | 5-28 |
| 5.3 | External operation | 5-30 |
| 5.3.1 | Use the set frequency set by the operation panel (Pr. 79 = 3) | 5-30 |
| 5.3.2 | Use switches to give a start command and a frequency command (multi-speed setting) (Pr. 4 to Pr. 6) | 5-32 |
| 5.3.3 | Perform frequency setting by analog voltage input | 5-35 |
| 5.3.4 | Change the frequency (40Hz) of the maximum value of potentiometer (at 5V) | 5-38 |
| 5.3.5 | Perform frequency setting by analog current input | 5-39 |
| 5.3.6 | Change the frequency (40Hz) of the maximum value of potentiometer (at 20mA) | 5-41 |

| | | |
|----------|--|------|
| 6 | Parameter | |
| 6.1 | Parameter overview | 6-1 |
| 6.2 | Control mode | 6-30 |
| 6.2.1 | Change the control method (Pr. 80, Pr. 81, Pr. 800) | 6-31 |
| 6.3 | Adjust the output torque (current) of the motor | 6-33 |
| 6.3.1 | Manual torque boost (Pr. 0, Pr. 46) | 6-33 |
| 6.3.2 | Advanced magnetic flux vector control (Pr. 71, Pr. 80, Pr. 81, Pr.89, Pr. 800) | 6-36 |
| 6.3.3 | General-purpose magnetic flux vector control (Pr. 71, Pr. 80, Pr. 81, Pr. 800) | 6-39 |
| 6.3.4 | Slip compensation (Pr. 245 to Pr. 247) | 6-41 |
| 6.3.5 | Stall prevention operation (Pr. 22, Pr. 23, Pr. 48, Pr. 66, Pr. 156, Pr. 157, Pr. 277) | 6-42 |
| 6.4 | Limit the output frequency | 6-50 |
| 6.4.1 | Maximum and minimum frequency (Pr. 1, Pr. 2, Pr. 18) | 6-50 |
| 6.4.2 | Avoid mechanical resonance points (frequency jumps) (Pr. 31 to Pr. 36) | 6-52 |
| 6.5 | Set V/f pattern | 6-54 |
| 6.5.1 | Base frequency, voltage (Pr. 3, Pr. 19, Pr. 47) | 6-54 |
| 6.5.2 | Load pattern selection (Pr. 14) | 6-56 |
| 6.6 | Frequency setting by external terminals | 6-58 |
| 6.6.1 | Multi-speed setting operation (Pr. 4 to Pr. 6, Pr. 24 to Pr. 27, Pr. 232 to Pr. 239) | 6-58 |
| 6.6.2 | Jog operation (Pr. 15, Pr. 16) | 6-61 |
| 6.6.3 | Remote setting function (Pr. 28) | 6-65 |
| 6.7 | Acceleration and deceleration | 6-69 |
| 6.7.1 | Acceleration and deceleration time (Pr. 7, Pr. 8, Pr. 20, Pr. 21, Pr. 44, Pr. 45, Pr. 147) | 6-69 |
| 6.7.2 | Starting frequency and start-time hold function | 6-73 |
| 6.7.3 | Acceleration and deceleration pattern (Pr. 29) | 6-75 |
| 6.7.4 | Shortest acceleration/deceleration (automatic acceleration/deceleration) (Pr. 61 to Pr. 63, Pr. 292, Pr. 293) | 6-77 |
| 6.8 | Selection and protection of a motor | 6-80 |
| 6.8.1 | Motor overheat protection (Electronic thermal O/L relay) (Pr. 9, Pr. 51) | 6-80 |
| 6.8.2 | Applied motor (Pr. 71, Pr. 450) | 6-85 |
| 6.8.3 | To exhibit the best performance of the motor performance (offline auto tuning) (Pr. 71, Pr. 80 to Pr. 84, Pr. 90 to Pr. 94, Pr. 96, Pr. 859) | 6-88 |

| | | |
|--------|--|-------|
| 6.9 | Motor brake and stop operation | 6-98 |
| 6.9.1 | DC injection brake (Pr. 10 to Pr. 12) | 6-98 |
| 6.9.2 | Selection of a regenerative brake (Pr. 30, Pr. 70) | 6-101 |
| 6.9.3 | Stop selection (Pr. 250) | 6-103 |
| 6.9.4 | Stop-on contact control function (Pr. 6, Pr. 48, Pr. 270, Pr. 275, Pr. 276) | 6-105 |
| 6.9.5 | Brake sequence function (Pr. 278 to Pr. 283, Pr. 292) | 6-109 |
| 6.10 | Function assignment of external terminals | 6-114 |
| 6.10.1 | Input terminal function selection (Pr. 178 to Pr. 184) | 6-114 |
| 6.10.2 | Inverter output shutoff signal (MRS signal, Pr. 17) | 6-117 |
| 6.10.3 | Condition selection of function validity by second function selection signal (RT, Pr. 155) | 6-119 |
| 6.10.4 | Start signal selection (Terminal STF, STR, STOP, Pr. 250) | 6-120 |
| 6.10.5 | Output terminal function selection (Pr. 190 to Pr. 192) | 6-124 |
| 6.10.6 | Detection of output frequency (SU, FU, Pr. 41 to Pr. 43) | 6-129 |
| 6.10.7 | Output current detection function (Y12, Y13, Pr. 150 to Pr. 153) | 6-131 |
| 6.10.8 | Remote output function (REM, Pr. 495 to Pr. 497) | 6-133 |
| 6.11 | Monitor display and monitor output signals | 6-136 |
| 6.11.1 | Speed display and speed setting (Pr. 37) | 6-136 |
| 6.11.2 | Monitor display selection of DU/PU and terminal AM (Pr. 52, Pr. 158, Pr. 170, Pr. 171, Pr. 268, Pr. 563, Pr. 564) | 6-138 |
| 6.11.3 | Reference of the terminal AM (analog voltage output) (Pr. 55, Pr. 56) | 6-146 |
| 6.11.4 | Terminal AM calibration [calibration parameter Pr. 645, C1 (Pr.901)] | 6-148 |
| 6.12 | Operation selection at power failure | 6-151 |
| 6.12.1 | Automatic restart (Pr. 30, Pr. 57, Pr. 58, Pr. 96, Pr. 162, Pr. 165, Pr. 298, Pr. 299, Pr. 611) | 6-151 |
| 6.12.2 | Power failure-time deceleration-to-stop function (Pr. 261) | 6-162 |
| 6.13 | Operation setting at alarm occurrence | 6-166 |
| 6.13.1 | Retry function (Pr. 65, Pr. 67 to Pr. 69) | 6-166 |
| 6.13.2 | Input/output phase failure protection selection (Pr. 251, Pr. 872) | 6-169 |
| 6.13.3 | Earth (ground) fault detection at start (Pr. 249) | 6-170 |
| 6.14 | Energy saving operation | 6-171 |
| 6.14.1 | Optimum excitation control (Pr. 60) | 6-171 |
| 6.15 | Motor noise, EMI measures, mechanical resonance | 6-172 |
| 6.15.1 | PWM carrier frequency and soft-PWM control (Pr. 72, Pr. 240) | 6-172 |
| 6.15.2 | Speed smoothing control (Pr. 653) | 6-173 |

| | | |
|--------|---|-------|
| 6.16 | Frequency setting by analog input (terminal 2, 4) | 6-174 |
| 6.16.1 | Analog input selection (Pr. 73, Pr. 267) | 6-174 |
| 6.16.2 | Input filter time constant (Pr. 74) | 6-179 |
| 6.16.3 | Bias and gain of frequency setting voltage (current) [Pr. 125, Pr. 126, Pr. 241, C2 (Pr. 902) to C7 (Pr. 905)] | 6-180 |
| 6.17 | Misoperation prevention and parameter setting restriction. | 6-187 |
| 6.17.1 | Reset selection/disconnected PU detection/PU stop selection (Pr. 75) | 6-187 |
| 6.17.2 | Parameter write selection (Pr. 77) | 6-192 |
| 6.17.3 | Reverse rotation prevention selection (Pr. 78) | 6-194 |
| 6.17.4 | User groups (Pr. 160, Pr. 172 to Pr. 174) | 6-195 |
| 6.18 | Selection of operation mode and operation location | 6-198 |
| 6.18.1 | Operation mode selection (Pr. 79) | 6-198 |
| 6.18.2 | Operation mode at power on (Pr. 79, Pr. 340) | 6-210 |
| 6.18.3 | Start command source and frequency command source during communication operation (Pr. 338, Pr. 339, Pr. 550, Pr. 551) | 6-212 |
| 6.19 | Communication operation and setting | 6-221 |
| 6.19.1 | PU connector | 6-221 |
| 6.19.2 | Initial settings and specifications of RS-485 communication (Pr. 117 to Pr. 120, Pr. 123, Pr. 124, Pr. 549) | 6-226 |
| 6.19.3 | Communication E ² PROM write selection (Pr. 342) | 6-232 |
| 6.19.4 | Mitsubishi inverter protocol (computer link communication) | 6-233 |
| 6.19.5 | Modbus-RTU communication (Pr. 117, Pr. 118, Pr. 120, Pr. 122, Pr. 343, Pr. 549) | 6-251 |
| 6.19.6 | USB communication (Pr. 547, Pr. 548) | 6-269 |
| 6.20 | Special operation | 6-270 |
| 6.20.1 | PID control (Pr. 127 to Pr. 134) | 6-270 |
| 6.20.2 | Dancer control (Pr. 44, Pr. 45, Pr. 128 to Pr. 134) | 6-282 |
| 6.20.3 | Droop control (Pr. 286 to Pr. 287) | 6-291 |
| 6.20.4 | Regeneration avoidance function (Pr. 665, Pr. 882, Pr. 883, Pr. 885, Pr. 886) | 6-292 |
| 6.21 | Useful functions | 6-295 |
| 6.21.1 | Cooling fan operation selection (Pr. 244) | 6-295 |
| 6.21.2 | Display of the life of the inverter parts (Pr. 255 to Pr. 259) | 6-296 |
| 6.21.3 | Maintenance timer alarm (Pr. 503, Pr. 504) | 6-300 |
| 6.21.4 | Current average value monitor signal (Pr. 555 to Pr. 557) | 6-301 |
| 6.21.5 | Free parameters (Pr. 888, Pr. 889) | 6-305 |

| | | |
|--------|---|-------|
| 6.22 | Setting for the parameter unit, operation panel | 6-306 |
| 6.22.1 | RUN key rotation direction selection (Pr. 40) | 6-306 |
| 6.22.2 | PU display language selection (Pr. 145) | 6-306 |
| 6.22.3 | Operation panel frequency setting/key lock operation selection (Pr. 161) | 6-307 |
| 6.22.4 | Magnitude of frequency change setting (Pr. 295) | 6-308 |
| 6.22.5 | Buzzer control (Pr. 990) | 6-309 |
| 6.22.6 | PU contrast adjustment (Pr. 991) | 6-309 |

7 Troubleshooting

| | | |
|--------|---|------|
| 7.1 | List of alarm display | 7-2 |
| 7.2 | Causes and corrective actions | 7-4 |
| 7.3 | Reset method of protective function | 7-16 |
| 7.4 | LED display | 7-17 |
| 7.5 | Check and clear of the fault history | 7-18 |
| 7.6 | Check first when you have troubles | 7-20 |
| 7.6.1 | Motor does not start | 7-20 |
| 7.6.2 | Motor or machine generates abnormal noise | 7-22 |
| 7.6.3 | Inverter generates abnormal noise | 7-22 |
| 7.6.4 | Motor generates heat abnormally | 7-23 |
| 7.6.5 | Motor rotates in opposite direction | 7-23 |
| 7.6.6 | Speed greatly differs from the setting | 7-23 |
| 7.6.7 | Acceleration/deceleration is not smooth | 7-24 |
| 7.6.8 | Speed varies during operation | 7-25 |
| 7.6.9 | Operation mode is not changed properly | 7-26 |
| 7.6.10 | Operation panel display is not operating | 7-26 |
| 7.6.11 | Motor current is too large | 7-27 |
| 7.6.12 | Speed does not accelerate | 7-28 |
| 7.6.13 | Unable to write parameter setting | 7-29 |
| 7.7 | Meters and measuring methods | 7-30 |
| 7.7.1 | Measurement of powers | 7-31 |
| 7.7.2 | Measurement of voltages and use of PT | 7-32 |
| 7.7.3 | Measurement of currents | 7-32 |
| 7.7.4 | Use of CT and transducer | 7-33 |
| 7.7.5 | Measurement of inverter input power factor | 7-33 |
| 7.7.6 | Measurement of converter output voltage (across terminals + and -) | 7-33 |

| | | | |
|----------|---|-----------------------------------|------|
| 8 | | Maintenance and inspection | |
| 8.1 | Inspection | | 8-1 |
| | 8.1.1 Daily inspection | | 8-1 |
| | 8.1.2 Periodic inspection | | 8-1 |
| | 8.1.3 Daily and periodic inspection | | 8-2 |
| | 8.1.4 Display of the life of the inverter parts | | 8-4 |
| | 8.1.5 Checking the inverter and converter modules | | 8-5 |
| | 8.1.6 Cleaning | | 8-6 |
| | 8.1.7 Replacement of parts | | 8-6 |
| | 8.1.8 Inverter replacement | | 8-10 |
| 8.2 | Measurements on the main circuit | | 8-11 |
| | 8.2.1 Insulation resistance test using megger | | 8-11 |
| | 8.2.2 Pressure test | | 8-11 |
| | 8.2.3 Measurement of voltages and currents | | 8-12 |
| A | | Appendix | |
| A.1 | Specifications | | A-1 |
| | A.1.1 1-phase, 200V class | | A-1 |
| | 8.2.4 3-phase, 400V class | | A-2 |
| A.2 | Common specifications | | A-3 |
| A.3 | Outline dimension drawings | | A-5 |
| | A.3.1 FR-E720S-008 to 030 | | A-5 |
| | A.3.2 FR-E720S-050 and 080 | | A-6 |
| | A.3.3 FR-E720S-110 and FR-E740-016 to 095 | | A-7 |
| | A.3.4 FR-E740-120 and 170 | | A-8 |
| | A.3.5 FR-E740-230 and 300 | | A-8 |
| | A.3.6 Parameter unit FR-PU07 | | A-9 |
| | A.3.7 Parameter unit FR-PA07 | | A-10 |
| A.4 | Parameter list with instruction codes | | A-11 |

1 Product checking and part identification

Unpack the inverter and check the capacity plate on the front cover and the rating plate on the inverter side face to ensure that the product agrees with your order and the inverter is intact.

1.1 Inverter type

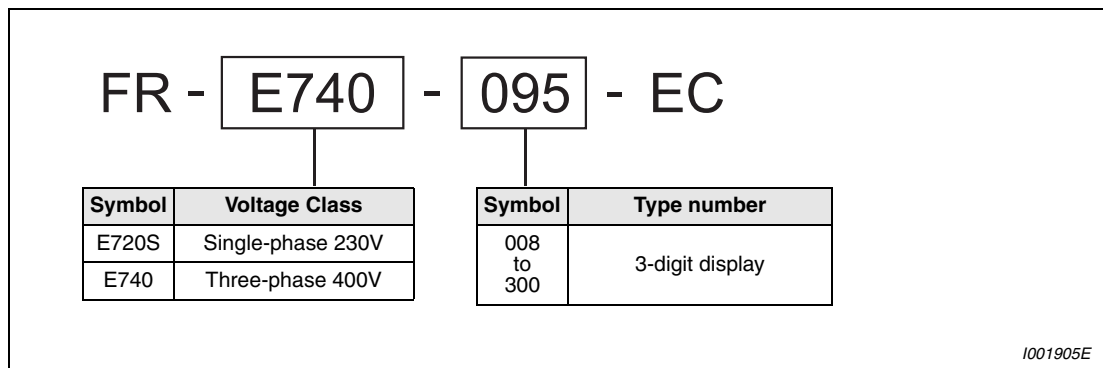

Fig. 1-1: Inverter type FR-E700 EC

1.2 Description of the Case

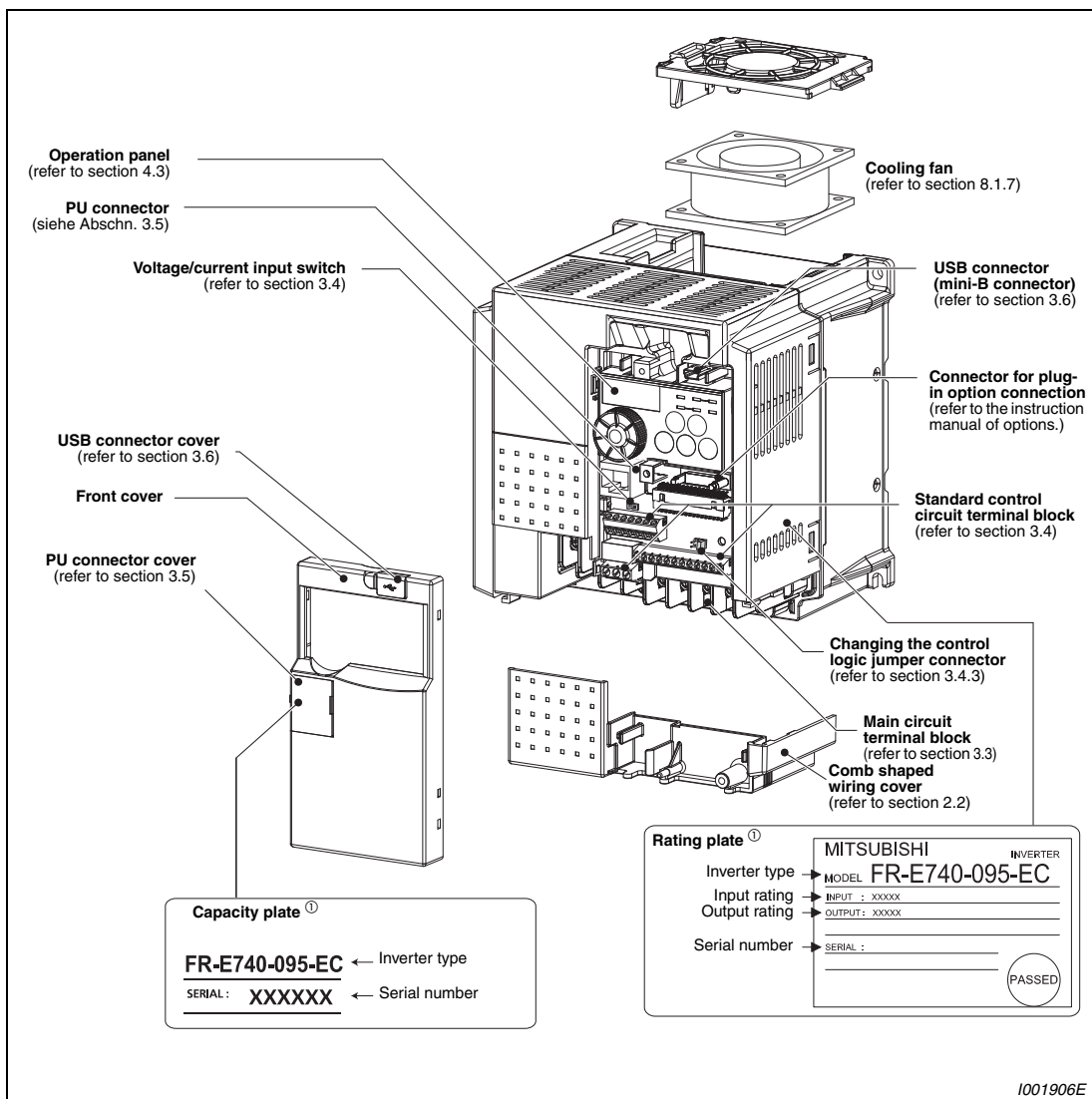

Fig. 1-2: Appearance and Structure

① Location of the capacity plate and the rating plate differs according to the inverter capacity. Refer to the outline dimension drawing. (Refer to section A.3.)

NOTE

For removal and reinstallation of covers, refer to section 2.1.

1.2.1 Accessory

Fan cover fixing screws

| Capacity | Screw Size [mm] | Number |
|---------------------|-----------------|--------|
| FR-E720S-050 to 110 | M3 × 35 | 1 |
| FR-E740-040 to 095 | M3 × 35 | 1 |
| FR-E740-120 to 300 | M3 × 35 | 2 |

Tab. 1-1: Fan cover fixing screws

NOTES

The fan cover fixing screws are not delivered with models FR-E720S-008 to 030 and FR-E740-026 or less.

For removal and reinstallation of the cooling fans, refer to section 8.1.7.

2 Installation

2.1 Removal and reinstallation of the front cover

2.1.1 FR-E720S and FR-E740-016 to FR-E740-170

Removal

Remove the front cover by pulling it toward you in the direction of arrow (refer to the figure below).

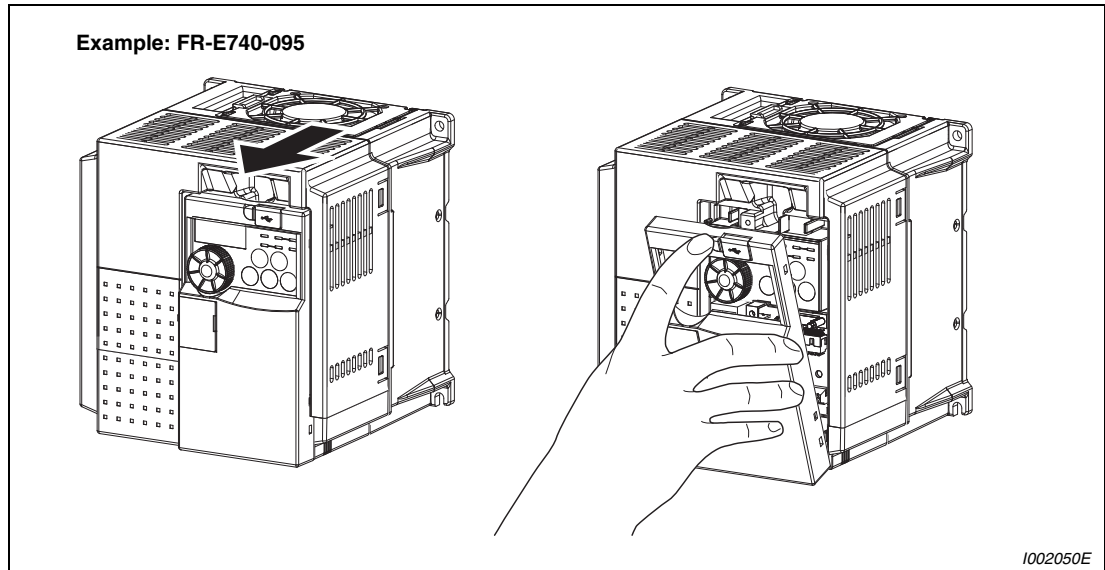

Fig. 2-1: Removal of the front cover

Reinstallation

To reinstall, match the cover to the inverter front and install it straight.

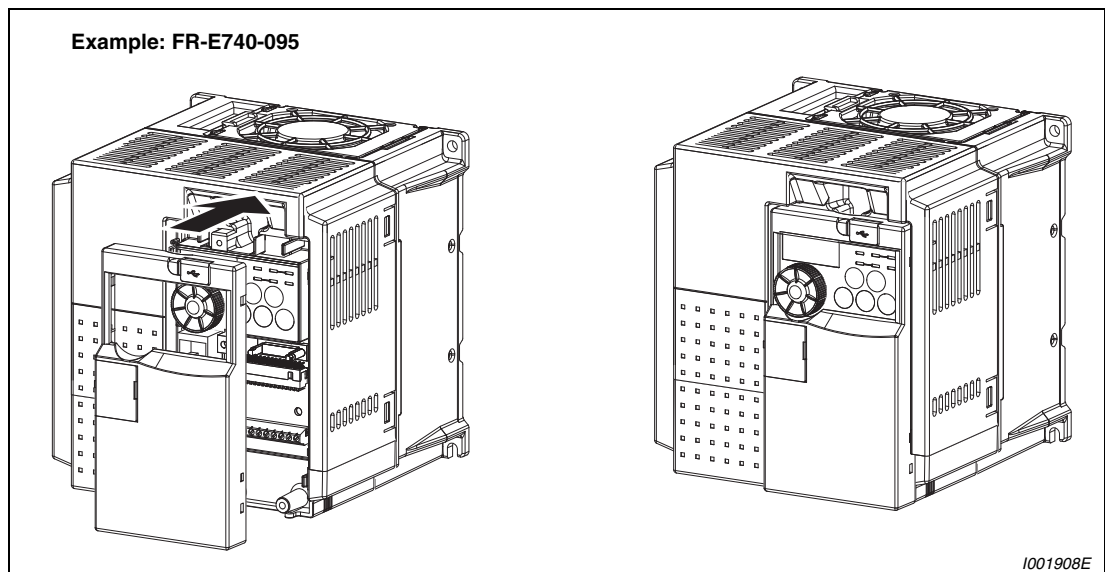

Fig. 2-2: Reinstallation of the front cover

2.1.2 FR-E740-230 and FR-E740-300

Removal

Loosen the installation screws of the front cover 1. Remove the front cover 1 by pulling it toward you in the direction of arrow.

Remove the front cover 2 by pulling it toward you in the direction of arrow (refer to the figure below).

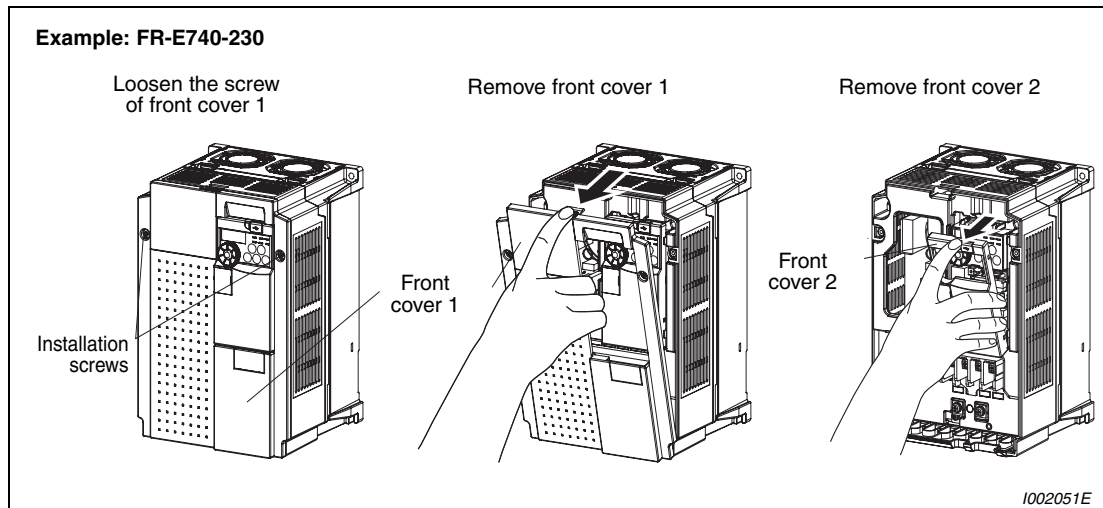

Fig. 2-3: Removal of the front cover

Reinstallation

Match the front cover 2 to the inverter front and install it straight.

Insert the two fixed hooks on the lower side of the front cover 1 into the sockets of the inverter.

Tighten the screw of the front cover 1.

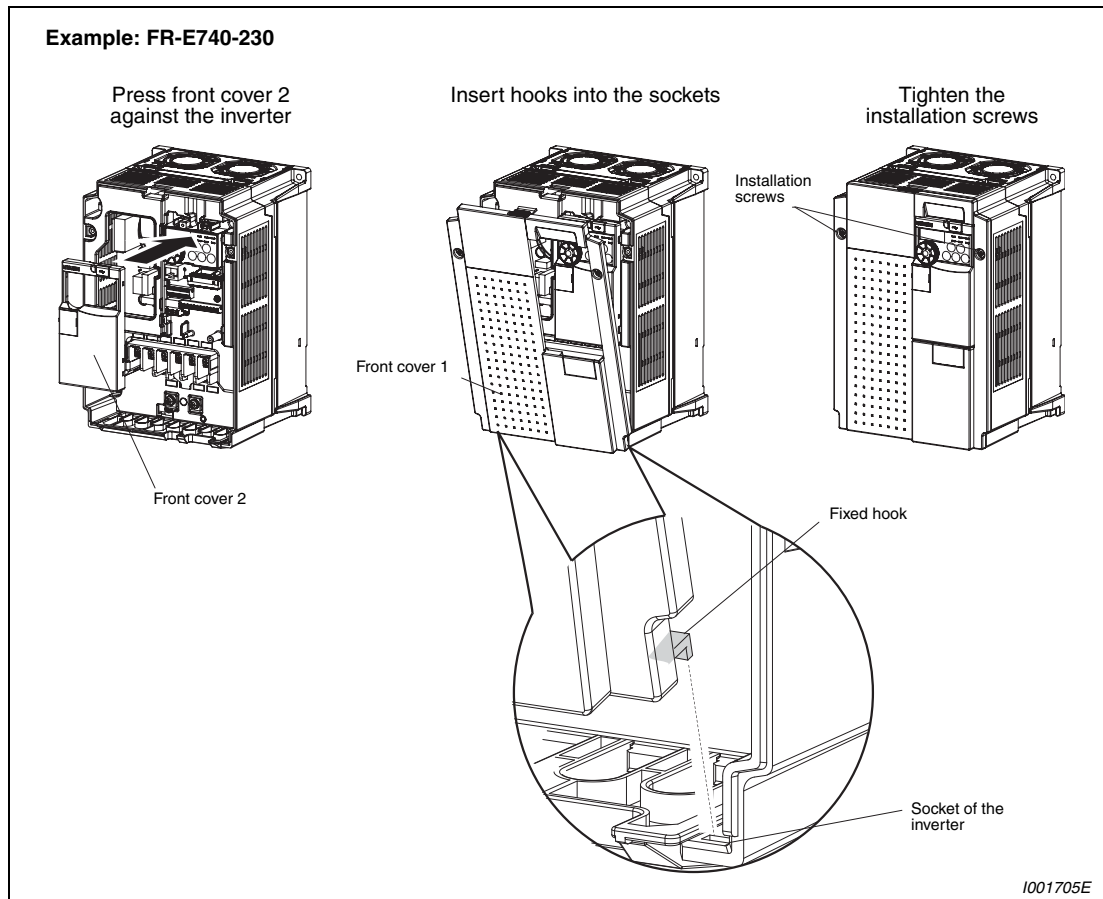

Fig. 2-4: Reinstallation of the front cover

NOTES

Fully make sure that the front cover has been reinstalled securely. Always tighten the installation screws of the front cover.

The same serial number is printed on the capacity plate of the front cover and the rating plate of the inverter. Before reinstalling the front cover, check the serial numbers to ensure that the cover removed is reinstalled to the inverter from where it was removed.

2.2 Removal and reinstallation of the wiring cover

The cover can be removed easily by pulling it toward you. To reinstall, fit the cover to the inverter along the guides.

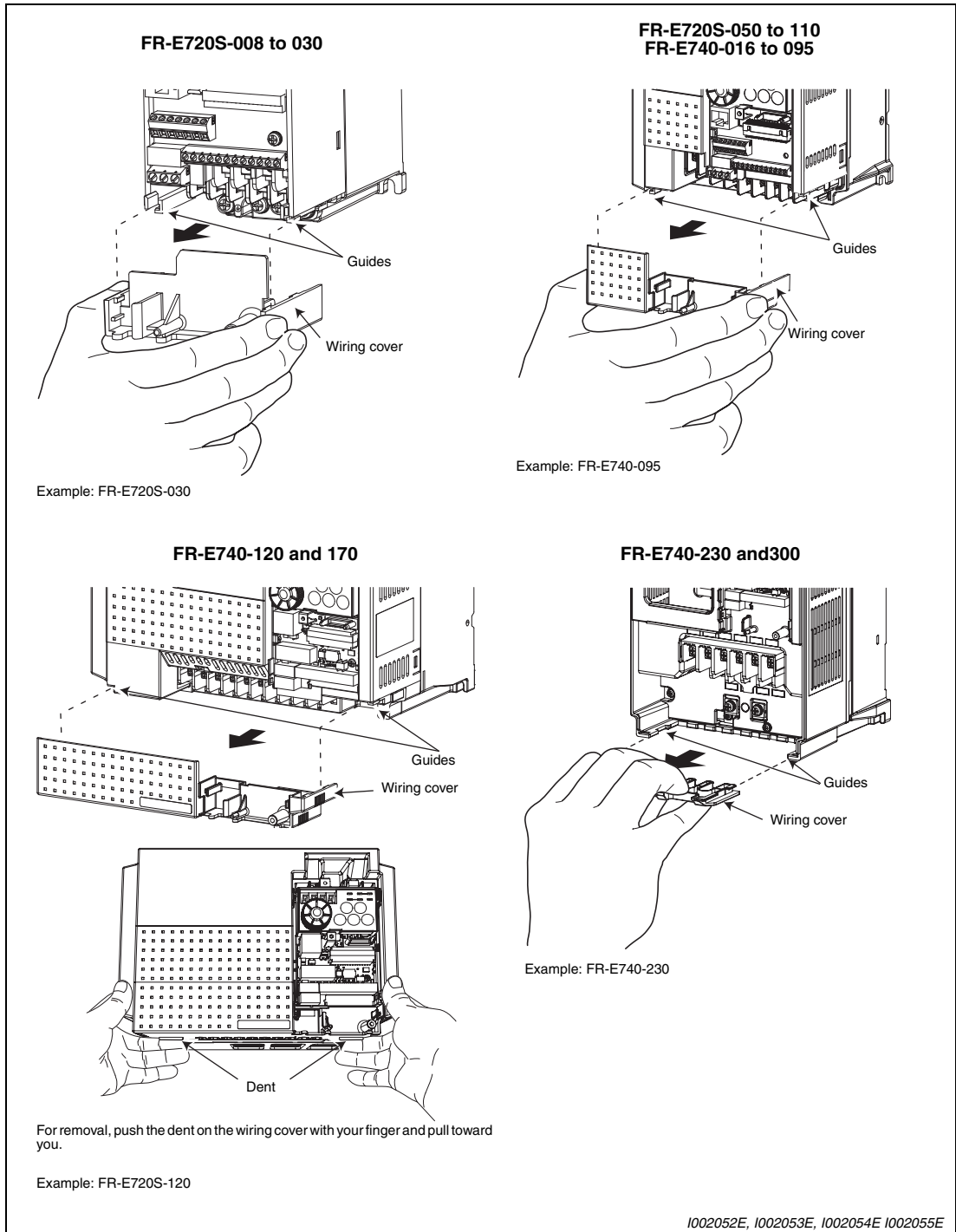

Fig. 2-5: Removing the wiring cover

2.3 Mounting

NOTE | Install the inverter vertically. Do not mount it horizontally or any other way.

Remove the front cover and wiring cover to fix the inverter to the surface.

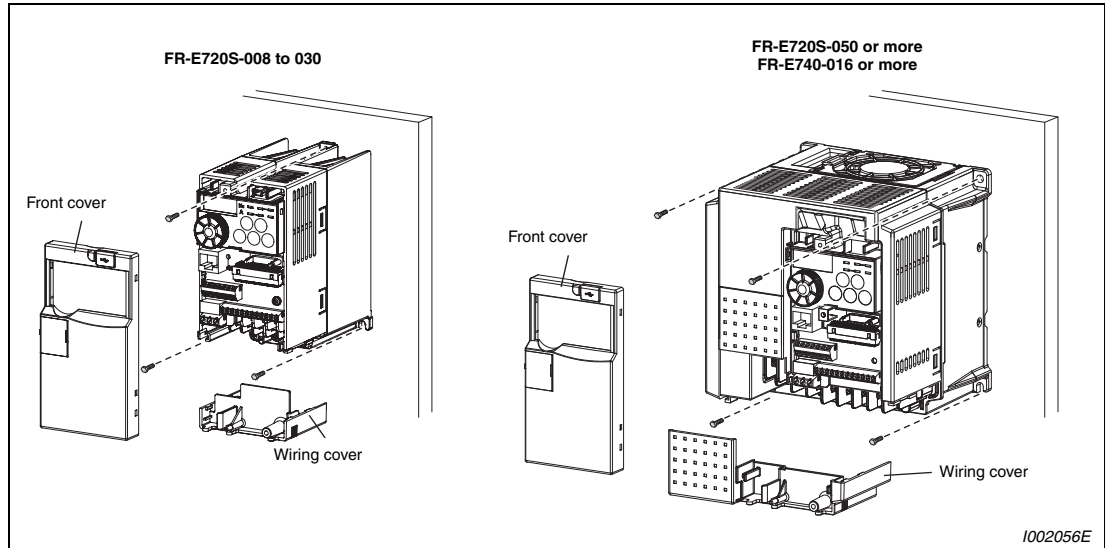

Fig. 2-6: Installation on the panel

NOTE | When encasing multiple inverters, install them in parallel as a cooling measure. Leave enough clearances around the inverter (refer to page 2-11).

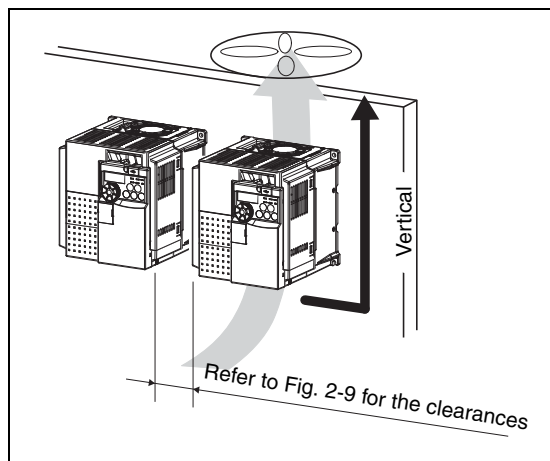

Fig. 2-7: Good heat dissipation is achieved through the vertical alignment of the frequency inverter, the side-by-side mounting and maintenance of minimum clearances.

I001911E

The inverter consists of precision mechanical and electronic parts. Never install or handle it in any of the following conditions as doing so could cause an operation fault or failure.

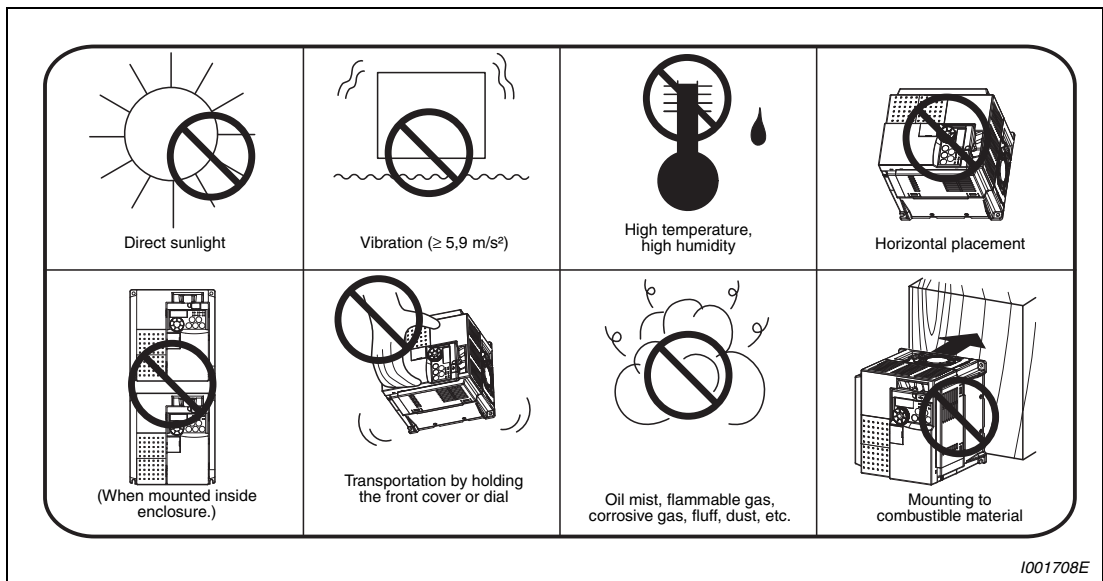

Fig. 2-8: Conditions, that could cause an operation fault or failure

2.4 Enclosure design

When an inverter enclosure is to be designed and manufactured, heat generated by contained equipment, etc., the environment of an operating place, and others must be fully considered to determine the enclosure structure, size and equipment layout. The inverter unit uses many semiconductor devices. To ensure higher reliability and long period of operation, operate the inverter in the ambient environment that completely satisfies the equipment specifications.

2.4.1 Inverter installation environment

As the inverter installation environment should satisfy the standard specifications indicated in the following table, operation in any place that does not meet these conditions not only deteriorates the performance and life of the inverter, but also causes a failure. Refer to the following points and take adequate measures.

| Item | Specification |
|---------------------|--|
| Ambient temperature | -10°C to +50°C (non-freezing) |
| Ambient humidity | 90% RH or less (non-condensing) |
| Atmosphere | Free from corrosive and explosive gases, dust and dirt |
| Maximum altitude | 1000m or less |
| Vibration | 5.9m/s ² or less (0,6 g) at 10 to 55Hz (directions of X, Y, Z axes) |

Tab. 2-1: Environmental standard specifications of inverter

Temperature

The permissible ambient temperature of the inverter FR-E700 is between -10 and +50°C. Always operate the inverter within this temperature range. Operation outside this range will considerably shorten the service lives of the semiconductors, parts, capacitors and others. Take the following measures so that the ambient temperature of the inverter falls within the specified range.

- Measures against high temperature
 - Use a forced ventilation system or similar cooling system. (Refer to page 2-10.)
 - Install the enclosure in an air-conditioned electrical chamber.
 - Block direct sunlight.
 - Provide a shield or similar plate to avoid direct exposure to the radiated heat and wind of a heat source.
 - Ventilate the area around the enclosure well.
- Measures against low temperature
 - Provide a space heater in the enclosure.
 - Do not power off the inverter. (Keep the start signal of the inverter off.)
- Sudden temperature changes
 - Select an installation place where temperature does not change suddenly.
 - Avoid installing the inverter near the air outlet of an air conditioner.
 - If temperature changes are caused by opening/closing of a door, install the inverter away from the door.

Humidity

Normally operate the inverter within the 45% to 90% range of the ambient humidity. Too high humidity will pose problems of reduced insulation and metal corrosion. On the other hand, too low humidity may produce a spatial electrical breakdown. The insulation distance specified in JEM1103 "Control Equipment Insulator" is defined as humidity 45% to 85%.

- Measures against high humidity

- Make the enclosure enclosed, and provide it with a hygroscopic agent.
- Take dry air into the enclosure from outside.
- Provide a space heater in the enclosure

- Measures against low humidity

What is important in fitting or inspection of the unit in this status is to discharge your body (static electricity) beforehand and keep your body from contact with the parts and patterns, besides blowing air of proper humidity into the enclosure from outside.

- Measures against condensation

Condensation may occur if frequent operation stops change the in-enclosure temperature suddenly or if the outside air temperature changes suddenly. Condensation causes such faults as reduced insulation and corrosion.

- Take the measures against high humidity.
- Do not power off the inverter. (Keep the start signal of the inverter off.)

Dust, dirt, oil mist

Dust and dirt will cause such faults as poor contact of contact points, reduced insulation or reduced cooling effect due to moisture absorption of accumulated dust and dirt, and in-enclosure temperature rise due to clogged filter.

In the atmosphere where conductive powder floats, dust and dirt will cause such faults as malfunction, deteriorated insulation and short circuit in a short time.

Since oil mist will cause similar conditions, it is necessary to take adequate measures.

- Measures against dust, dirt, oil mist

- Place in a totally enclosed enclosure.
Take measures if the in-enclosure temperature rises. (Refer to page 2-10.)
- Purge air.
Pump clean air from outside to make the in-enclosure pressure higher than the outside-air pressure.

Corrosive gas, salt damage

If the inverter is exposed to corrosive gas or to salt near a beach, the printed board patterns and parts will corrode or the relays and switches will result in poor contact. In such places, take the measures against dust, dirt, oil mist.

Explosive, flammable gases

As the inverter is non-explosion proof, it must be contained in an explosion proof enclosure. In places where explosion may be caused by explosive gas, dust or dirt, an enclosure cannot be used unless it structurally complies with the guidelines and has passed the specified tests. This makes the enclosure itself expensive (including the test charges). The best way is to avoid installation in such places and install the inverter in a non-hazardous place.

Highland

Use the inverter at the altitude of within 1000m.

If it is used at a higher place, it is likely that thin air will reduce the cooling effect and low air pressure will deteriorate dielectric strength.

Vibration, impact

The vibration resistance of the inverter is up to 5.9m/s^2 at 10 to 55Hz frequency and 1mm amplitude for the directions of X, Y, Z axes.

Vibration or impact, if less than the specified value, applied for a long time may make the mechanism loose or cause poor contact to the connectors.

Especially when impact is imposed repeatedly, caution must be taken as the part pins are likely to break.

● Countermeasures

- Provide the enclosure with rubber vibration isolators.
- Strengthen the structure to prevent the enclosure from resonance.
- Install the enclosure away from sources of vibration.

Cooling system types for inverter enclosure

From the enclosure that contains the inverter, the heat of the inverter and other equipment (transformers, lamps, resistors, etc.) and the incoming heat such as direct sunlight must be dissipated to keep the in-enclosure temperature lower than the permissible temperatures of the in-enclosure equipment including the inverter.

The cooling systems are classified as follows in terms of the cooling calculation method.

- Cooling by natural heat dissipation from the enclosure surface (Totally enclosed type)
- Cooling by heat sink (Aluminium fin, etc.)
- Cooling by ventilation (Forced ventilation type, pipe ventilation type)
- Cooling by heat exchanger or cooler (Heat pipe, cooler, etc.)

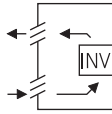
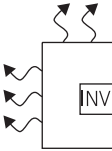
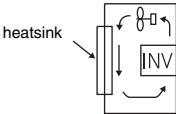
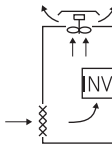
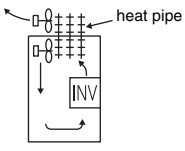
| Cooling System | | Enclosure Structure | Comment |
|-----------------|---|---|--|
| Natural cooling | Natural ventilation (Enclosed, open type) |  <p style="text-align: center;">1001000E</p> | Low in cost and generally used, but the enclosure size increases as the inverter capacity increases. For relatively small capacities. |
| | Natural ventilation (Totally enclosed type) |  <p style="text-align: center;">1001001E</p> | Being a totally enclosed type, the most appropriate for hostile environment having dust, dirt, oil mist, etc. The enclosure size increases depending on the inverter capacity. |
| Forced cooling | Heatsink cooling |  <p style="text-align: center;">1001002E</p> | Having restrictions on the heatsink mounting position and area, and designed for relative small capacities. |
| | Forced ventilation |  <p style="text-align: center;">1001003E</p> | For general indoor installation. Appropriate for enclosure downsizing and cost reduction, and often used. |
| | Heat pipe |  <p style="text-align: center;">1001004E</p> | Totally enclosed type for enclosure downsizing. |

Tab. 2-2: Cooling system types for inverter enclosure

2.4.2 Inverter placement

Clearances around the inverter

Always observe the specified minimum clearances to ensure good heat dissipation and adequate accessibility of the frequency inverter for servicing.

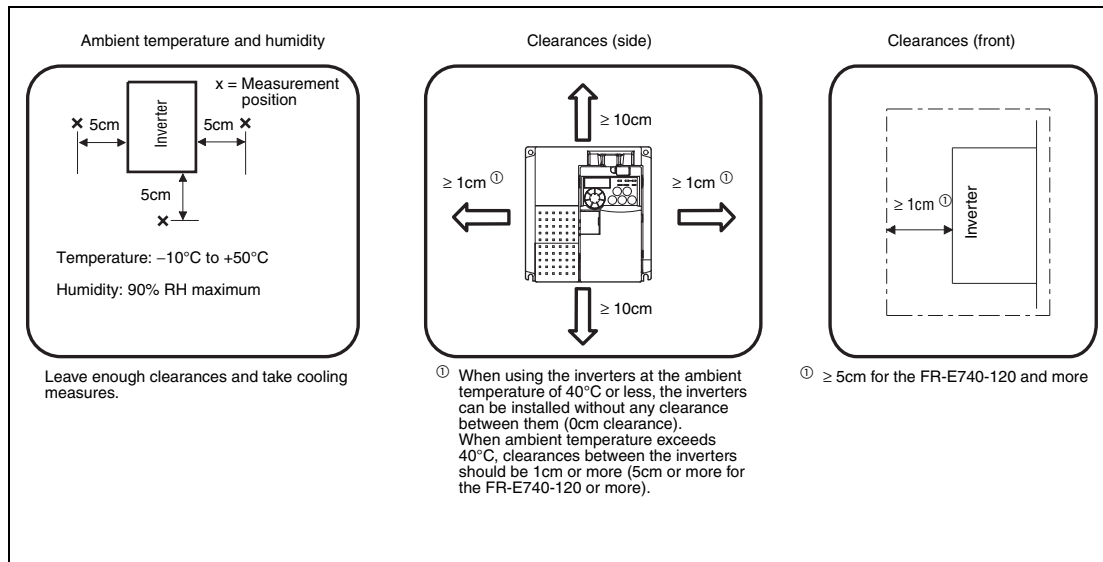

Fig. 2-9: Clearances

Inverter mounting orientation

Mount the inverter on a wall as specified. Do not mount it horizontally or any other way.

Above the inverter

Heat is blown up from inside the inverter by the small fan built in the unit. Any equipment placed above the inverter should be heat resistant.

Arrangement of multiple inverters

When multiple inverters are placed in the same enclosure, generally arrange them horizontally as shown in the figure (a). When it is inevitable to arrange them vertically to minimize space, take such measures as to provide guides since heat from the bottom inverters can increase the temperatures in the top inverters, causing inverter failures.

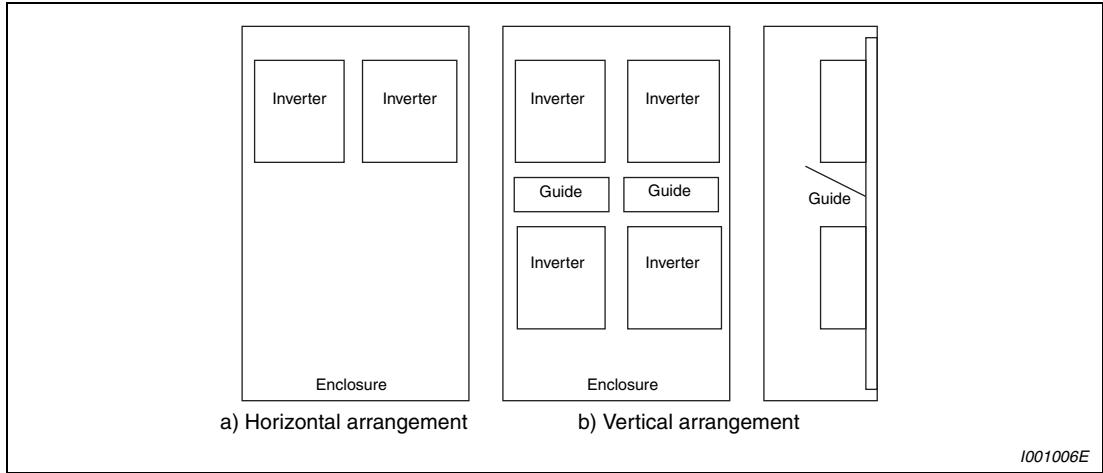

Fig. 2-10: Arrangement of multiple inverters

NOTE

When mounting multiple inverters, fully take caution not to make the ambient temperature of the inverter higher than the permissible value by providing ventilation and increasing the enclosure size.

Placement of ventilation fan and inverter

Heat generated in the inverter is blown up from the bottom of the unit as warm air by the cooling fan. When installing a ventilation fan for that heat, determine the place of ventilation fan installation after fully considering an air flow. (Air passes through areas of low resistance. Make an airway and airflow plates to expose the inverter to cool air.)

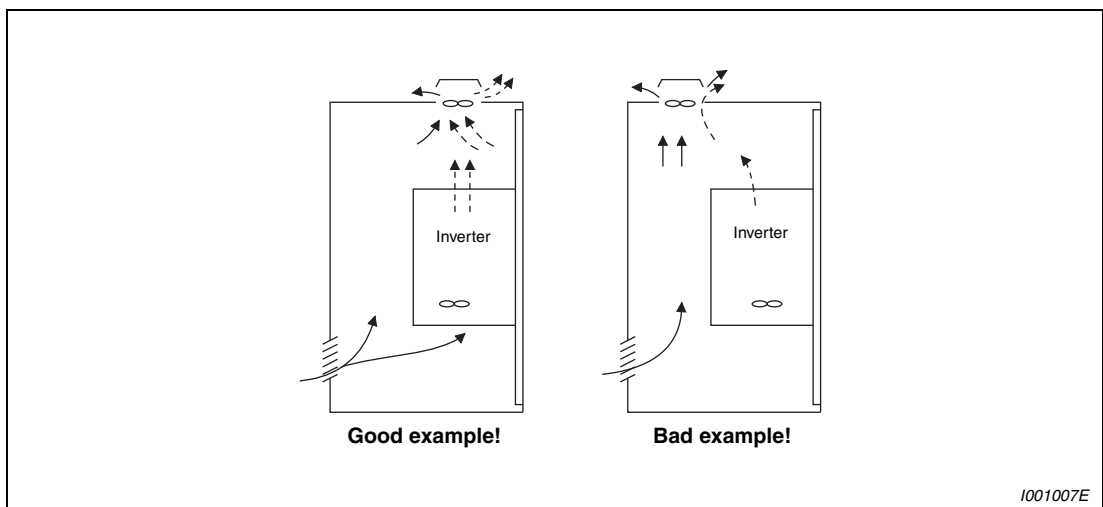

Fig. 2-11: Placement of ventilation fan and inverter

3 Wiring

3.1 Inverter and peripheral devices

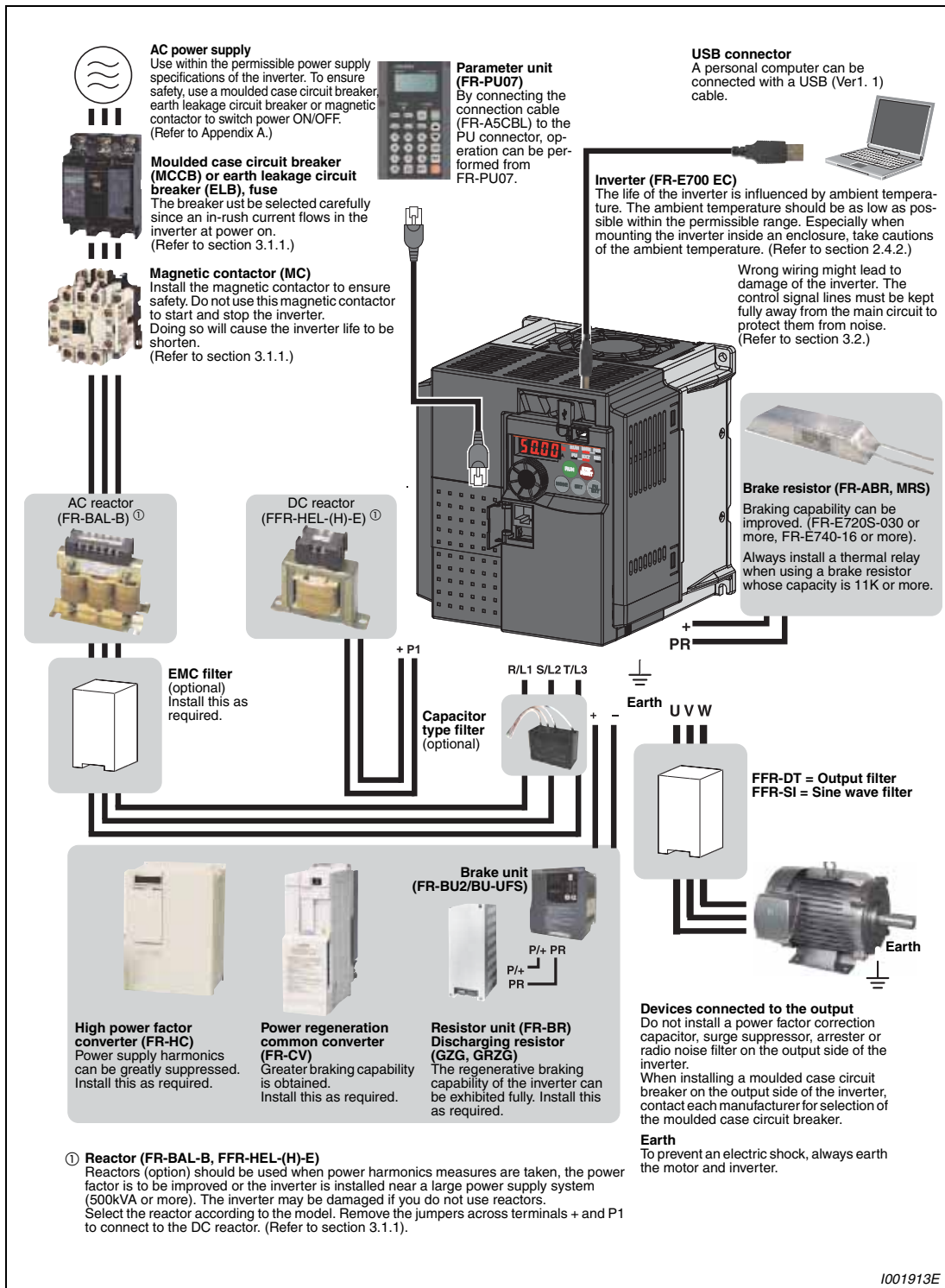

Fig. 3-1: System configuration overview

NOTES

Do not install a power factor correction capacitor or surge suppressor on the inverter output side. This will cause the inverter to trip or the capacitor and surge suppressor to be damaged. If any of the above devices are connected, immediately remove them.

Electromagnetic Compatibility

Operation of the frequency inverter can cause electromagnetic interference in the input and output that can be propagated by cable (via the power input lines), by wireless radiation to nearby equipment (e.g. AM radios) or via data and signal lines.

Activate the integrated EMC filter (and an additional optional filter if present) to reduce air propagated interference on the input side of the inverter. Use AC or DC reactors to reduce line propagated noise (harmonics). Use shielded motor power lines to reduce output noise (refer also to section 3.8 Electromagnetic Compatibility).

Refer to the instruction manual of each option and peripheral devices for details of peripheral devices.

3.1.1 Peripheral devices

Check the motor capacity of the inverter you purchased. Appropriate peripheral devices must be selected according to the capacity. Refer to the following list and prepare appropriate peripheral devices:

| | Motor output [kW] | Applicable Inverter Type | Breaker Selection ① | | Input Side Magnetic Contactor ② | |
|------------|-------------------|--------------------------|---------------------|-----------------|---------------------------------|-------|
| | | | Reactor connection | | Reactor connection | |
| | | | Without | With | Without | With |
| 200V class | 0.1 | FR-E720S-008 | NF32 xx 3P 5 A | | S-N10 | |
| | 0.2 | FR-E720S-015 | | | | |
| | 0.4 | FR-E720S-030 | NF32 xx 3P 10 A | | | |
| | 0.75 | FR-E720S-050 | NF32 xx 3P 15 A | NF32 xx 3P 10 A | | |
| | 1.5 | FR-E720S-080 | NF63 xx 3P 20 A | | | |
| | 2.2 | FR-E720S-110 | NF32 xx 3P 40 A | NF32 xx 3P 32 A | S-N20, S-N21 | S-N10 |
| 400V class | 0.4 | FR-E740-016 | NF32 xx 3P 5 A | | S-N10 | |
| | 0.75 | FR-E740-026 | | | | |
| | 1.5 | FR-E740-040 | NF32 xx 3P 10 A | | | |
| | 2.2 | FR-E740-060 | NF32 xx 3P 15 A | NF32 xx 3P 10 A | | |
| | 3.7 | FR-E740-095 | NF63 xx 3P 20 A | NF32 xx 3P 15 A | | |
| | 5.5 | FR-E740-120 | NF63 xx 3P 30 A | NF63 xx 3P 20 A | S-N20 | S-N11 |
| | 7.5 | FR-E740-170 | NF63 xx 3P 30 A | NF63 xx 3P 30 A | S-N20 | |
| | 11 | FR-E740-230 | NF63 xx 3P 50 A | NF63 xx 3P 40 A | | |
| | 15 | FR-E740-300 | NF125 xx 3P 100 A | NF63 xx 3P 50 A | S-N25 | S-N20 |

Tab. 3-1: Breakers and contactors

- ① Select the MCCB according to the inverter power supply capacity. Install one MCCB per inverter. The places with "xx" refer to the breaking capacity in case of short circuit. The correct selection must be done depending on the design of the power input wiring.

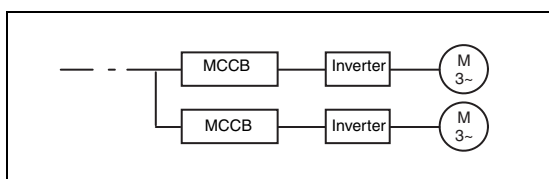

Fig. 3-2: Installation of the breakers

1001332E

- ② Magnetic contactor is selected based on the AC-1 class. The electrical durability of magnetic contactor is 500,000 times. When the magnetic contactor is used for emergency stop during motor driving, the electrical durability is 25 times. When using the MC for emergency stop during motor driving or using on the motor side during commercial-power supply operation, select the MC with class AC-3 rated current for the motor rated current.

NOTES

When the inverter capacity is larger than the motor capacity, select an MCCB and a magnetic contactor according to the inverter type and cable and reactor according to the motor output.

When the breaker on the inverter primary side trips, check for the wiring fault (short circuit), damage to internal parts of the inverter, etc. Identify the cause of the trip, then remove the cause and power on the breaker.

3.2 Terminal connection diagramm

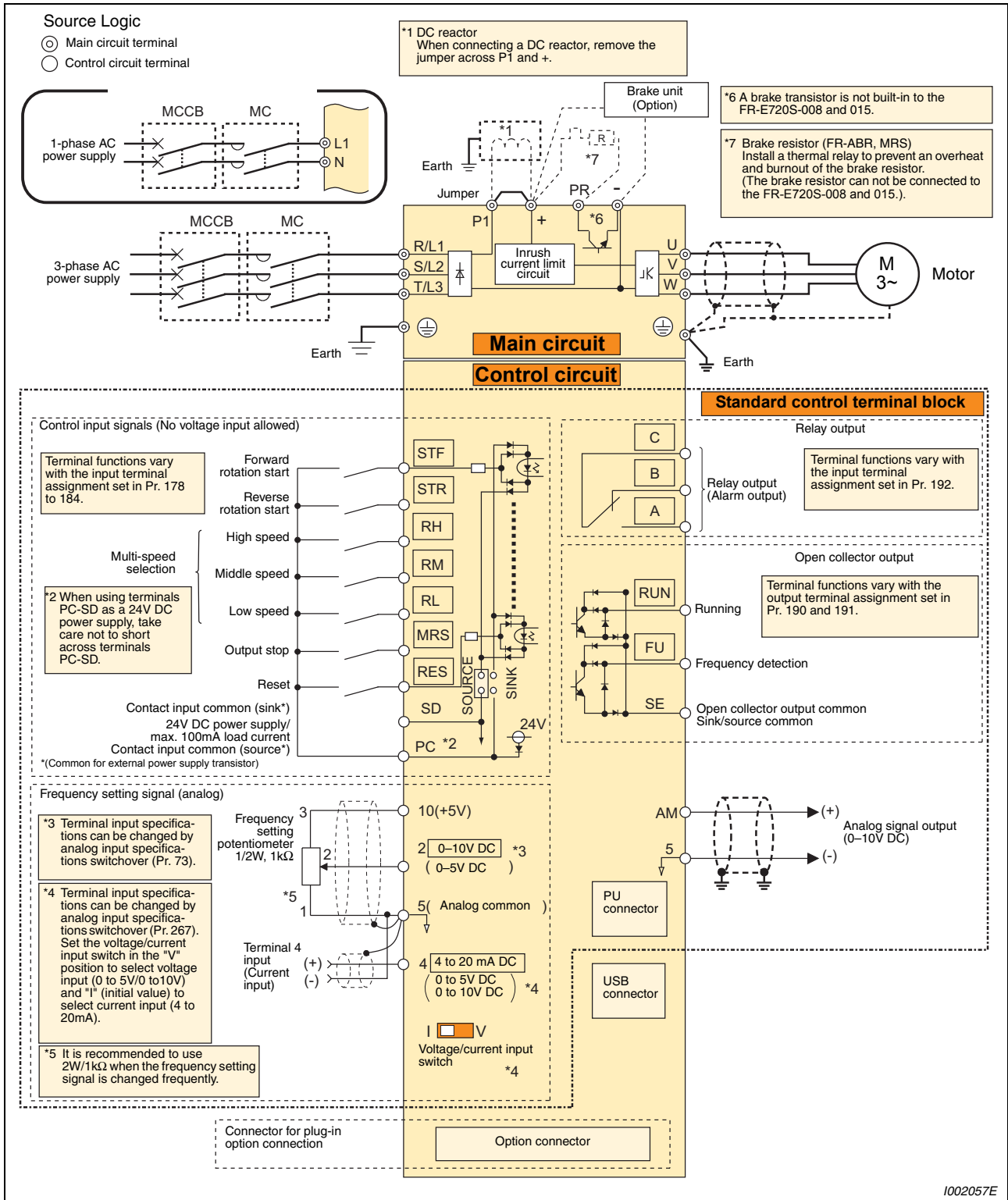

1002057E

Fig. 3-3: Terminal connection diagram of the inverter

NOTES

To prevent a malfunction due to noise, keep the signal cables more than 10cm away from the power cables. Also separate the main circuit wire of the input side and the output side.

After wiring, wire offcuts must not be left in the inverter.

Wire offcuts can cause an alarm, failure or malfunction. Always keep the inverter clean.

When drilling mounting holes in an enclosure etc., take care not to allow chips and other foreign matter to enter the inverter.

The output of the single-phase power input specification is three-phase 230V.

3.3 Main circuit connection

3.3.1 Specification of main circuit terminal

| Terminal | Name | Description |
|---|---------------------------|---|
| R/L1, S/L2, T/L3 ① | AC power input | Connect to the commercial power supply. Keep these terminals open when using the high power factor converter (FR-HC) or power regeneration common converter (FR-CV). |
| U, V, W | Inverter output | Voltage output of the inverter (3~, 0V—power supply voltage, 0.2–400 Hz) |
| +, PR | Brake resistor connection | Connect a brake transistor (FR-ABR, MRS) across terminals + and PR. (The brake resistor can not be connected to the FR-E720S-008 and 015.) |
| +, – | Brake unit connection | Connect the brake unit (FR-BU2), power regeneration common converter (FR-CV) or high power factor converter (FR-HC). |
| +, P1 | DC reactor connection | Remove the jumper across terminals + and P1 and connect a DC reactor. |
|  | PE | For earthing the inverter chassis. Must be earthed. |

Tab. 3-2: Specification of main circuit terminal

① When using single-phase power input, terminals are L1, N.

3.3.2 Terminal layout and wiring

Single-phase, 200V class

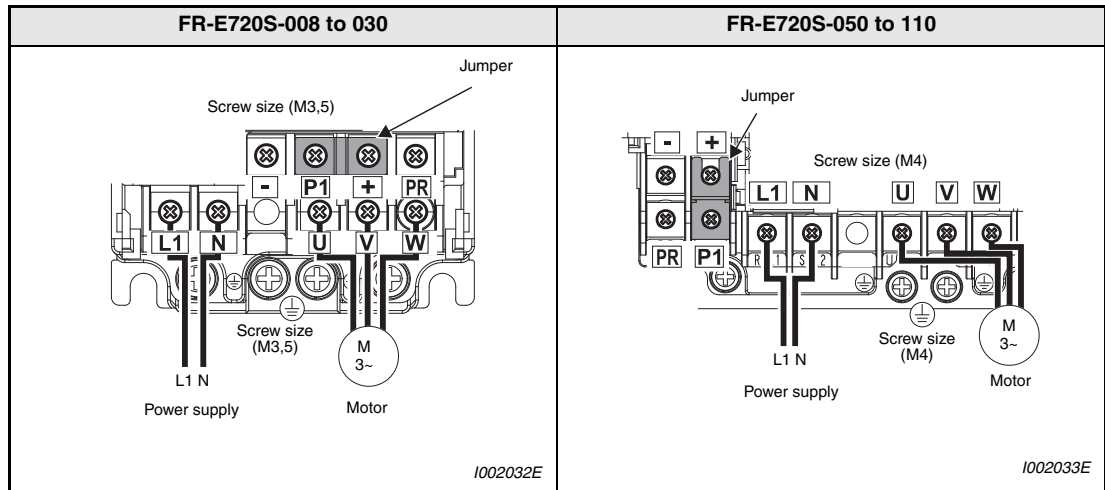

Tab. 3-3: Terminal layout and wiring

Three-phase, 400V class

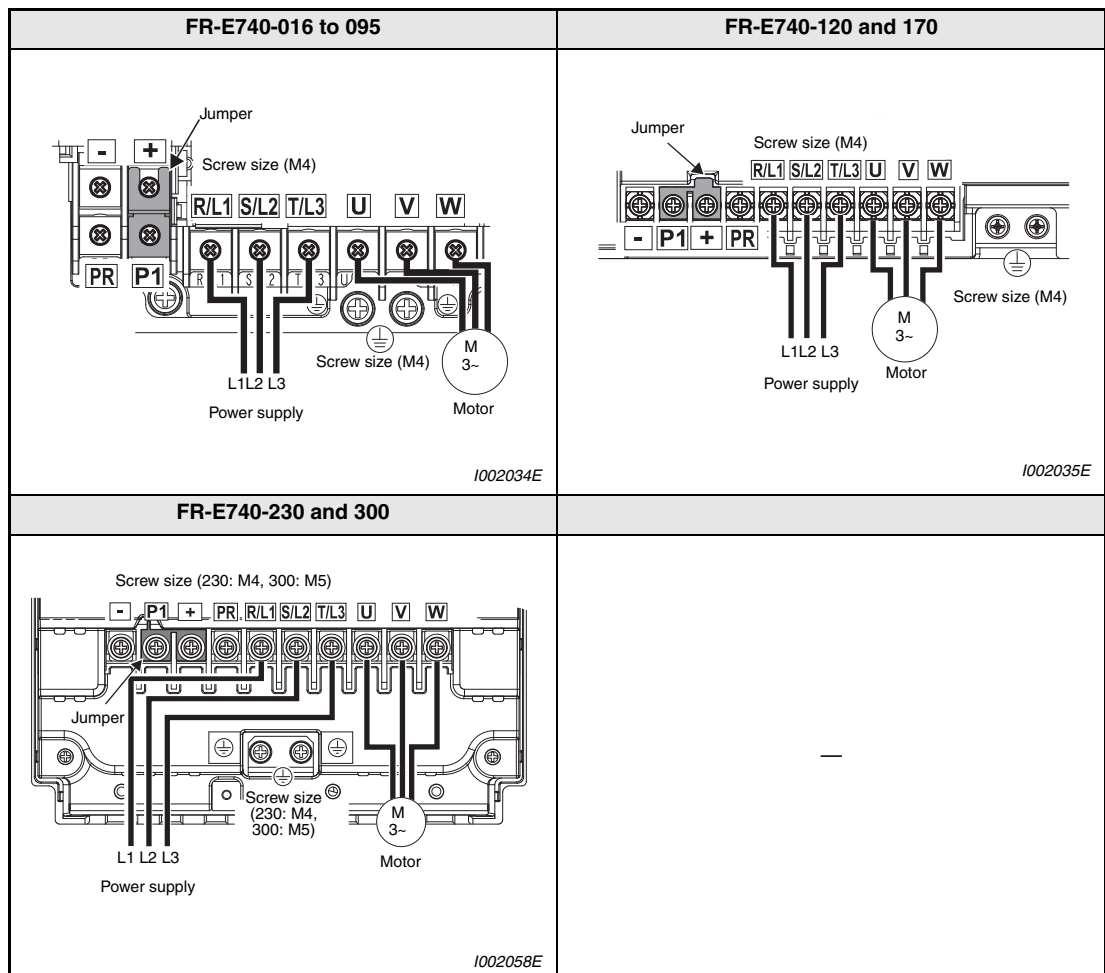

Tab. 3-4: Terminal layout and wiring

**CAUTION:**

- *The power supply cables must be connected to R/L1, S/L2, T/L3. Never connect the power cable to the U, V, W of the inverter. Doing so will damage the inverter. (Phase sequence needs not to be matched.)*
- *Connect the motor to U, V, W. At this time, turning on the forward rotation switch (signal) rotates the motor in the counter clockwise direction when viewed from the motor shaft.*

Cables and wiring length

Select the recommended cable size to ensure that a voltage drop will be 2% max.
If the wiring distance is long between the inverter and motor, a main circuit cable voltage drop will cause the motor torque to decrease especially at the output of a low frequency.

The following tables indicate a selection example for the wiring length of 20m.

200V class (when input power supply is 230V)

| Applicable Inverter Type | Terminal Screw Size ④ | Tightening Torque [Nm] | Crimping Terminal | | Cable Size | | | | | | | |
|--------------------------|-----------------------|------------------------|-------------------|---------|-------------------------------|---------|-------------------|--------------|---------|--------------------------|---------|-------------------|
| | | | | | HIV etc. [mm ²] ① | | | AWG ② | | PVC [mm ²] ③ | | |
| | | | L1, N, P1, + | U, V, W | L1, N, P1, + | U, V, W | Earth cable gauge | L1, N, P1, + | U, V, W | L1, N, P1, + | U, V, W | Earth cable gauge |
| FR-E720S-008 to 030 | M3.5 | 1.2 | 2-3.5 | 2-3.5 | 2 | 2 | 2 | 14 | 14 | 2.5 | 2.5 | 2.5 |
| FR-E720S-050 | M4 | 1.5 | 2-4 | 2-4 | 2 | 2 | 2 | 14 | 14 | 2.5 | 2.5 | 2.5 |
| FR-E720S-080 | M4 | 1.5 | 2-4 | 2-4 | 2 | 2 | 2 | 14 | 14 | 2.5 | 2.5 | 2.5 |
| FR-E720S-110 | M4 | 1.5 | 5.5-4 | 2-4 | 3.5 | 2 | 3.5 | 12 | 14 | 4 | 2.5 | 4 |

Tab. 3-5: Cable size

400V class (when input power supply is 440V)

| Applicable Inverter Type | Terminal Screw Size ④ | Tightening Torque [Nm] | Crimping Terminal | | Cable Size | | | | | | | |
|--------------------------|-----------------------|------------------------|-------------------------|---------|-------------------------------|---------|-------------------|-------------------------|---------|--------------------------|---------|-------------------|
| | | | | | HIV etc. [mm ²] ① | | | AWG ② | | PVC [mm ²] ③ | | |
| | | | R/L1, S/L2, T/L3, P1, + | U, V, W | R/L1, S/L2, T/L3, P1, + | U, V, W | Earth cable gauge | R/L1, S/L2, T/L3, P1, + | U, V, W | R/L1, S/L2, T/L3, P1, + | U, V, W | Earth cable gauge |
| FR-E740-016 to 095 | M4 | 1.5 | 2-4 | 2-4 | 2 | 2 | 2 | 14 | 14 | 2.5 | 2.5 | 2.5 |
| FR-E740-120 | M4 | 1.5 | 5.5-4 | 2-4 | 3.5 | 2 | 3.5 | 12 | 14 | 4 | 2.5 | 4 |
| FR-E740-170 | M4 | 1.5 | 5.5-4 | 5.5-4 | 3.5 | 3.5 | 3.5 | 12 | 12 | 4 | 4 | 4 |
| FR-E740-230 | M4 | 1.5 | 5.5-4 | 5.5-4 | 5.5 | 5.5 | 8 | 10 | 10 | 6 | 6 | 10 |
| FR-E740-300 | M5 | 2.5 | 8-5 | 8-5 | 8 | 8 | 8 | 8 | 8 | 10 | 10 | 10 |

Tab. 3-6: Cable size

- ① The recommended cable size is that of the HIV cable (600 V class 2 vinyl-insulated cable) with continuous maximum permissible temperature of 75 °C. Assumes that the ambient temperature is 50 °C or less and the wiring distance is 20 m or less.
- ② The recommended cable size is that of the THHW cable with continuous maximum permissible temperature of 75 °C. Assumes that the ambient temperature is 40 °C or less and the wiring distance is 20 m or less.
(Selection example for use mainly in the United States.)
- ③ The recommended cable size is that of the PVC cable with continuous maximum permissible temperature of 70°C. Assumes that the ambient temperature is 40°C or less and the wiring distance is 20m or less.
(Selection example for use mainly in Europe.)
- ④ The terminal screw size indicates the terminal size for R/L1, S/L2, T/L3, U, V, W, and a screw for earthing. (For single-phase power input, the terminal screw size indicates the size of terminal screw for L1, N, U, V, W, PR, +, – and P1 and a screw for earthing (grounding).)

The line voltage drop can be calculated by the following expression:

$$\text{Line voltage drop [V]} = \frac{\sqrt{3} \times \text{wire resistance [m}\Omega/\text{m}] \times \text{wiring distance [m]} \times \text{current [A]}}{1000}$$

Use a larger diameter cable when the wiring distance is long or when it is desired to decrease the voltage drop (torque reduction) in the low speed range.

**CAUTION:**

- *Tighten the terminal screw to the specified torque. A screw that has been tightened too loosely can cause a short circuit or malfunction. A screw that has been tightened too tightly can cause a short circuit or malfunction due to the unit breakage.*
- *Use crimping terminals with insulation sleeve to wire the power supply and motor.*

Notes on earthing



CAUTION:
Leakage currents flow in the inverter or the EMC filter respectively. To prevent an electric shock, the inverter, input filter and motor must be earthed. (This inverter must be earthed. Earthing must conform to the requirements of national and local safety regulations and electrical codes. (JIS, NEC section 250, IEC 536 class 1 and other applicable standards)).

Use the dedicated earth terminal to earth the inverter. (Do not use the screw in the casing, chassis, etc.)

Use the thickest possible earth cable. Use the cable whose size is equal to or greater than that indicated in Tab. 3-6, and minimize the cable length. The earthing point should be as near as possible to the inverter.

Always earth the motor and inverter

● Purpose of earthing

Generally, an electrical apparatus has an earth terminal, which must be connected to the ground before use.

An electrical circuit is usually insulated by an insulating material and encased. However, it is impossible to manufacture an insulating material that can shut off a leakage current completely, and actually, a slight current flow into the case. The purpose of earthing the case of an electrical apparatus is to prevent operator from getting an electric shock from this leakage current when touching it.

To avoid the influence of external noises, this earthing is important to audio equipment, sensors, computers and other apparatuses that handle low-level signals or operate very fast.

● Earthing methods and earthing work

As described previously, earthing is roughly classified into an electrical shock prevention type and a noise affected malfunction prevention type. Therefore, these two types should be discriminated clearly, and the following work must be done to prevent the leakage current having the inverter's high frequency components from entering the malfunction prevention type earthing:

- Where possible, use independent earthing for the inverter. If independent earthing (I) is impossible, use joint earthing (II) where the inverter is connected with the other equipment at an earthing point. Joint earthing as in (III) must be avoided as the inverter is connected with the other equipment by a common earth cable.

Also a leakage current including many high frequency components flows in the earth cables of the inverter and inverter-driven motor. Therefore, they must use the independent earthing method and be separated from the earthing of equipment sensitive to the aforementioned noises.

In a tall building, it will be a good policy to use the noise malfunction prevention type earthing with steel frames and carry out electric shock prevention type earthing in the independent earthing method.

- This inverter must be earthed. Earthing must conform to the requirements of national and local safety regulations and electrical codes. (JIS, NEC section 250, IEC 536 class 1 and other applicable standards).
- Use the thickest possible earth cable. The earth cable should be of not less than the size indicated in Tab. 3-6.
- The grounding point should be as near as possible to the inverter, and the ground wire length should be as short as possible.
- Run the earth cable as far away as possible from the I/O wiring of equipment sensitive to noises and run them in parallel in the minimum distance.

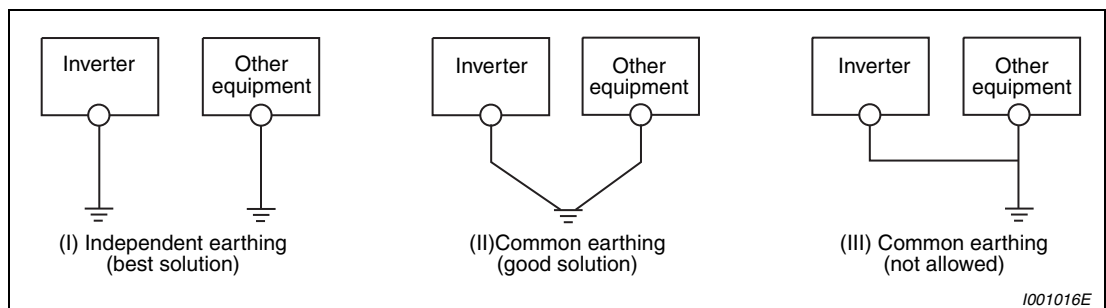

Fig. 3-4: Earthing the drive

Total wiring length

The maximum possible length of the motor cables depends on the capacity of the inverter and the selected carrier frequency.

The lengths in the following table are for unshielded cables. When shielded cables are use divide the values listed in the table by 2.

200V class

| Pr. 72 "PWM frequency selection" setting (carrier frequency) | FR-E720S- | | | | | |
|--|-----------|------|------|------|------|------|
| | 008 | 015 | 030 | 050 | 080 | 110 |
| ≤ 1 (1kHz) | 200m | 200m | 300m | 500m | 500m | 500m |
| 2 to 15 (2kHz to 14,5kHz) | 30m | 100m | 200m | 300m | 500m | 500m |

Tab. 3-7: Total wiring length

400V class

| Pr. 72 "PWM frequency selection" setting (carrier frequency) | FR-E740- | | | | |
|--|----------|------|------|------|-------|
| | 016 | 026 | 040 | 060 | ≥ 095 |
| ≤ 1 (1kHz) | 200m | 200m | 300m | 500m | 500m |
| 2 to 15 (2kHz to 14,5kHz) | 30m | 100m | 200m | 300m | 500m |

Tab. 3-8: Total wiring length

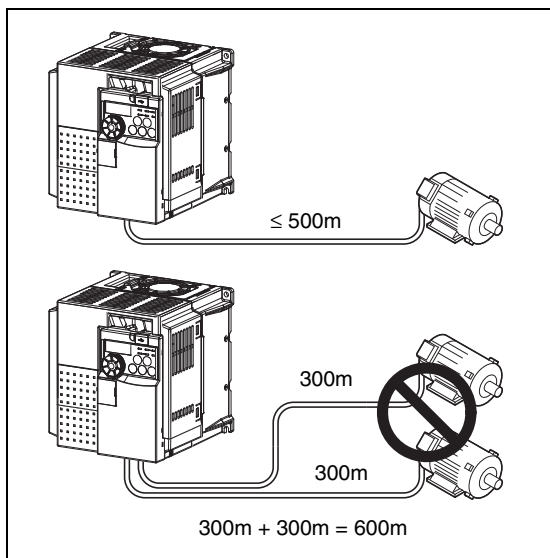

Fig. 3-5: Remember that in the table above the total wiring length is what is being referred to. In parallel connections of several motors every motor wire must be counted. In this example, for the frequency inverter with an output capacity of 3.7kW the permissible wiring length is exceeded by the two parallel motor lead wires.

I001904E

NOTES

Note that the motor windings are subjected to significantly higher loads when the motor is operated by inverter than with normal mains operation. The motors must be approved for inverter operation by the manufacturer (refer also to section 3.8.4).

Especially for long-distance wiring, the inverter may be affected by a charging current caused by the stray capacitances of the wiring, leading to a malfunction of the overcurrent protective function, fast response current limit function, or stall prevention function or a malfunction or fault of the equipment connected on the inverter output side.

If fast-response current limit malfunctions, disable this function. When the stall prevention function misoperates, increase the stall level. (Refer Pr. 22 "Stall prevention operation level" and Pr. 156 "Stall prevention operation selection".)

Refer to section 6.15.1 for details of Pr. 72 "PWM frequency selection".

When using the automatic restart after instantaneous power failure function with wiring length exceeding than 100m, select without frequency search (Pr. 162 = "1, 11").

3.4 Control circuit specifications

The functions of the terminals highlighted in grey can be adjusted with parameters 178 to 184 "Input terminal function assignment" and Pr. 190 to 192 "Output terminal function assignment" (refer to section 6.10). The listed settings show the default configuration as shipped, which you can restore by resetting to the factory defaults.

Input signals

| | Terminal | Name | Description | Rated Specifications | Refer to Page | |
|-----------------|------------|---|--|---|--|-------|
| Contact input | STF | Forward rotation start | Turn on the STF signal to start forward rotation and turn it off to stop. | When the STF and STR signals are turned on simultaneously, the stop command is given. | Input resistance: 4.7kΩ Voltage at opening: 21V to 26V DC Contacts at short-circuited: 4 to 6mA DC | 6-114 |
| | STR | Reverse rotation start | Turn on the STR signal to start reverse rotation and turn it off to stop. | | | |
| | RH, RM, RL | Multi-speed selection | Multi-speed can be selected according to the combination of RH, RM and RL signals. | | | |
| | MRS | Output stop | Turn on the MRS signal (20ms or more) to stop the inverter output. Use to shut off the inverter output when stopping the motor by electromagnetic brake. | | | |
| | RES | Reset | Used to reset alarm output provided when protective function is activated. Turn on the RES signal for more than 0.1s, then turn it off. Initial setting is for reset always. By setting Pr. 75, reset can be set to enabled only at an inverter alarm occurrence. Recover about 1s after reset is cancelled. | | | |
| Reference point | SD | Contact input common (sink) 24V DC power supply common | A determined control function is activated, if the corresponding terminal is connected to the terminal SD (sink logic). The SD terminal is isolated from the digital circuits via opto couplers. The terminal is isolated from the reference potential of the analog circuit (terminal 5). | — | — | |
| | PC | 24V DC power supply, contact input common (source) | 24V DC/0.1A output With negative logic and control via open collector transistors (e.g. a PLC) the positive pole of an external power source must be connected to the PC terminal. With positive logic the PC terminal is used as a common reference for the control inputs. This means that when positive logic is selected (default setting of the EC units) the corresponding control function is activated by connecting its terminal to the PC terminal. | Power supply voltage range: 22 V to 26,5 V DC Permissible load current: 100 mA | 3-20 | |

Tab. 3-9: Input signals (1)

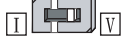
| | Terminal | Name | Description | Rated Specifications | Refer to Page |
|-------------------|------------------------------|--------------------------------|--|--|---------------|
| Frequency setting | 10 (Output voltage 5V DC) | Frequency setting power supply | Used as power supply when connecting potentiometer for frequency setting (speed setting) from outside of the inverter. Rated output voltage: 5V DC Recommended potentiometer: 1kΩ, 2W linear, multi turn potentiometer | 5.2V DC ± 0.2V, Permissible load current 10mA | 6-174 |
| | 2 | Frequency setting (voltage) | Inputting 0 to 5V DC (or 0 to 10V) provides the maximum output frequency at 5V (10V) and makes input and output proportional. Use Pr. 73 to switch from among input 0 to 5V DC (initial setting), 0 to 10V DC. | Input resistance: 10kΩ ± 1kΩ Maximum permissible voltage: 20V DC | |
| | 4 | Frequency setting (current) | Inputting 4 to 20mA DC (or 0 to 5V, 0 to 10V) provides the maximum output frequency at 20mA and makes input and output proportional. This input signal is valid only when the AU signal is on (terminal 2 input is invalid). Use Pr. 267 to switch from among input 4 to 20mA (initial setting), 0 to 5V DC and 0 to 10V DC. Set the voltage/current input switch in the "V" position to select voltage input (0 to 5V/0 to 10V). <div style="display: flex; justify-content: space-around; align-items: center;"> <div style="text-align: center;"> <p>Current input (initial status)</p>  </div> <div style="text-align: center;"> <p>Voltage input</p>  </div> </div> | Current input: Input resistance: 233Ω ± 5Ω Maximum permissible current: 30mA Voltage input: Input resistance: 10kΩ ± 1kΩ Maximum permissible voltage: 20V DC | |
| | 5 | Frequency setting common | Terminal 5 provides the common reference potential (0V) for all analog set point values and for the analog output signals AM (voltage). The terminal is isolated from the digital circuit's reference potential (SD). This terminal should not be grounded. If local regulations require grounding of the reference potential note that this can propagate any noise in the ground potential to the control electronics, thus increasing sensitivity to interference. | — | |

Tab. 3-9: Input signals (2)

NOTE

Set Pr. 267 and a voltage/current input switch correctly, then input analog signals in accordance with the settings. Applying a voltage with voltage/current input switch in "I" position (current input is selected) or a current with switch in "V" position (voltage input is selected) could cause component damage of the inverter or analog circuit of output devices. Refer to section 6.16 for details.

Output signals

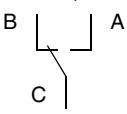
| | Terminal | Name | Description | Rated Specifications | Refer to Page | |
|---------------|----------|------------------------------|---|--|---|----------------|
| Relay | A, B, C | Relay output (alarm output) | <p>The alarm is output via relay contacts. The block diagram shows the normal operation and voltage free status. If the protective function is activated, the relay picks up.</p>  | <p>Contact capacity: 230V AC/0.3A (Power factor: 0.4) or 30V DC/0.3A</p> | 6-124 | |
| | | | | | | Open collector |
| | FU | Frequency detection | <p>The output is switched low once the output frequency exceeds a value preset in Pr. 42 (or 43). Otherwise the FU output is switched high.</p> | | | |
| | SE | Open collector output common | <p>Reference potential for the signals RUN and FU. This terminal is isolated from the reference potential of the control circuit SD.</p> | — | — | |
| Analog output | AM | Analog voltage output | <p>Select one e.g. output frequency from monitor items. The output signal is proportional to the magnitude of the corresponding monitoring item. Not output during inverter reset.</p> | <p>Output item: Output frequency (initial setting)</p> | <p>Output signal: 0–10V DC Permissible load current: 1 mA (load impedance: $\geq 10k\Omega$) Resolution: 8 bit</p> | 6-146 |

Tab. 3-10: Output signals

Communication

| | Name | Description | Specification | Refer to Page |
|--------|---------------|---|--|----------------|
| RS-485 | PU connector | <p>With the PU connector, communication can be made through RS-485.</p> | <p>Conforming standard: EIA-485 (RS-485) Transmission format: Multidrop Communication speed: 4800 to 38400bps Overall length: 500m</p> | 3-23, 6-221 |
| USB | USB connector | <p>The FR Configurator can be operated by connecting the inverter to the personal computer through USB.</p> | <p>Interface: conforms to USB1.1 Transmission speed: 12Mbps Connector: USB mini B connector (receptacle mini B type)</p> | 3-25, 6-269 |

Tab. 3-11: Communication signals

3.4.1 Control circuit terminals

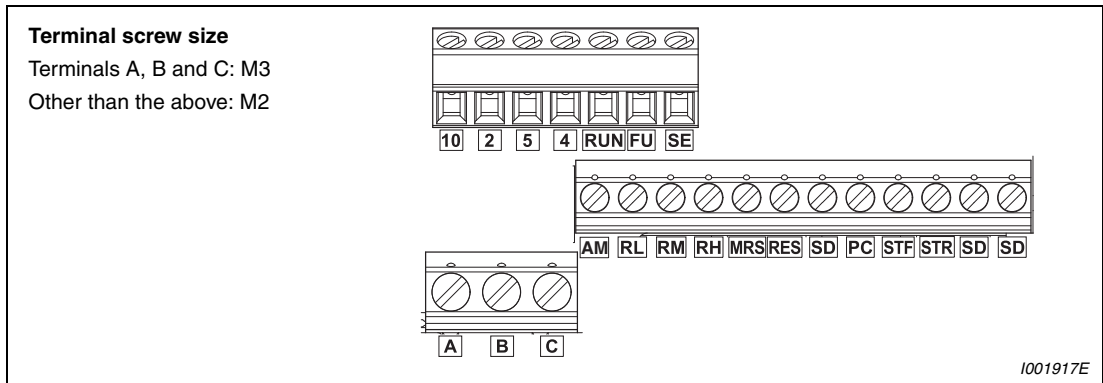

Fig. 3-6: Terminal layout

Wiring method

- Remove about 6mm of the cable insulation. Wire the stripped cable after twisting it to prevent it from becoming loose. In addition, do not solder it.

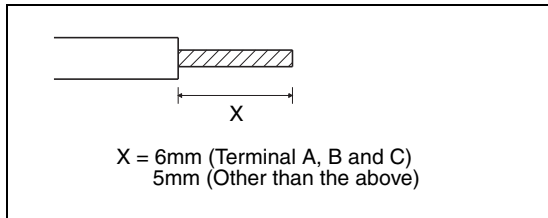

Fig. 3-7: Preparation of the cable

I001326E

- Loosen the terminal screw and insert the cable into the terminal.

| Item | Terminals A, B and C | Other terminals |
|-------------------|--|--|
| Screw size | M3 | M2 |
| Tightening torque | 0.5Nm–0.6Nm | 0.22 Nm–0.25 Nm |
| Cable size | 0.3mm ² –0.75mm ² | 0.3 mm ² –0.5 mm ² |
| Screwdriver | Flat blade screw driver Edge thickness: 0,4mm × 2,5mm | |

Tab. 3-12: Connection to the terminals



CAUTION:
 Undertightening can cause cable disconnection or malfunction. Overtightening can cause a short circuit or malfunction due to damage to the screw or unit.

Common terminals of the control circuits PC, 5, SE

Terminals PC, 5, and SE are all common terminals (0V) for I/O signals and are isolated from each other. Avoid connecting the terminal PC and 5 and the terminal SE and 5. Terminal PC is a common terminal for the contact input terminals (STF, STR, RH, RM, RL, MRS and RES).

The open collector circuit is isolated from the internal control circuit by photocoupler.

Terminal 5 is a common terminal for frequency setting signal (terminal 2 or 4) and analog output terminal AM. It should be protected from external noise using a shielded or twisted cable.

Terminal SE is a common terminal for the open collector output terminal RUN and FU.

The contact input circuit is isolated from the internal control circuit by photocoupler.

Signal inputs by contactless switch

The contacted input terminals of the inverter (STF, STR, RH, RM, RL, MRS and RES) can be controlled using a transistor instead of a contacted switch as shown below. According to the adjusted control logic, PNP transistors (positive logic) or NPN transistors (negative logic) must be used to activate the inputs.

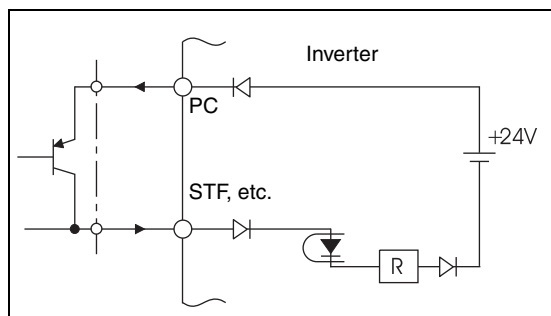

Fig. 3-8:
External signal input in source logic using transistor (initial setting)

1001020E

3.4.2 Wiring instructions

- Use shielded or twisted cables for connection to the control circuit terminals and run them away from the main and power circuits (including the 230V relay sequence circuit).
- Use two or more parallel micro-signal contacts or twin contacts to prevent a contact faults when using contact inputs since the control circuit input signals are micro-currents.

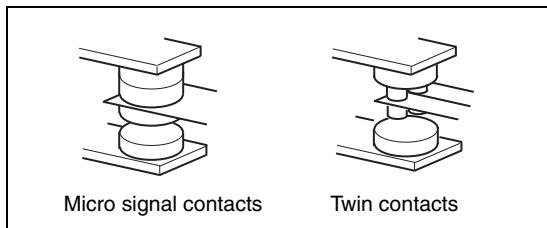

Fig. 3-9:
Contacts

1001021E

- Do not apply a voltage to the contact input terminals (e.g. STF) of the control circuit.
- Always apply a voltage to the alarm output terminals (A, B, C) via a relay coil, lamp, etc. In no way must a voltage be short-circuited by these relay contacts.
- It is recommended to use the cables of 0.75mm² gauge for connection to the control circuit terminals. If the cable gauge used is 1.25mm² or more, the front cover may be lifted when there are many cables running or the cables are run improperly, resulting in an operation panel contact fault.
- The wiring length should be 30m maximum.
- Do not short terminal PC and SD. Inverter may be damaged.

3.4.3 Changing the control logic

FR-E700 frequency inverters offer the possibility of choosing between two types of control logic. Depending on the direction of the flowing current, one distinguishes between:

- In sink logic, a signal switches on when a current flows from the corresponding signal input terminal. Terminal SD is common to the contact input signals. Terminal SE is common to the open collector output signals.
- In source logic, a signal switches on when a current flows into the corresponding signal input terminal. Terminal PC is common to the contact input signals. Terminal SE is common to the open collector output signals.

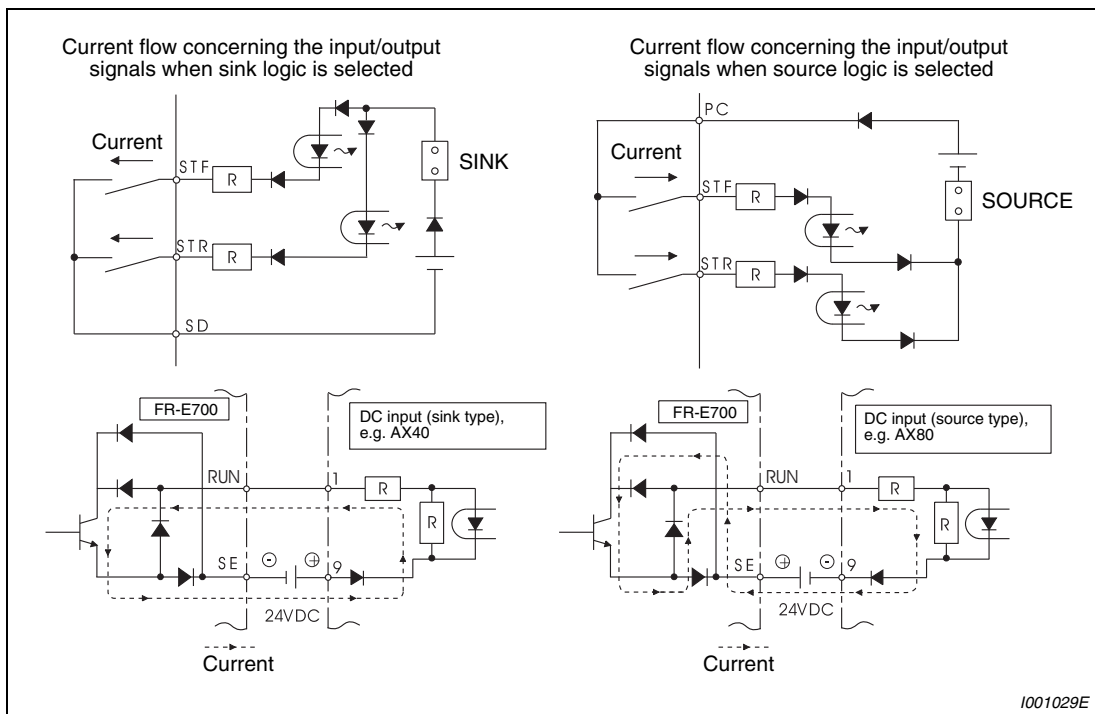

Fig. 3-10: Changing the control logic

The input signals are set to source logic (SOURCE) when shipped from the factory. To change the control logic, the jumper connector above the control circuit terminal block must be moved to the other position.

(The output signals may be used in either the sink or source logic independently of the jumper connector position.)

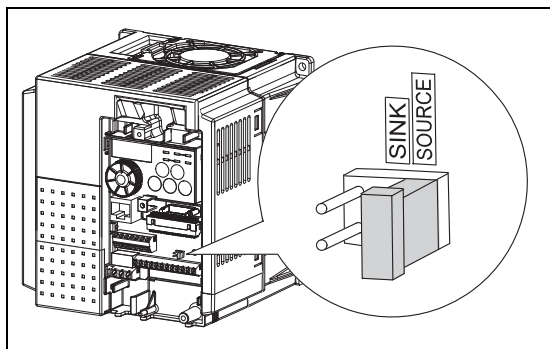

Fig. 3-11: Changing the control logic

1001918E

NOTES

Turn off the inverter power before switching a jumper connector.

The sink-source logic change-over jumper connector must be fitted in only one of those positions. If it is fitted in both positions at the same time, the inverter may be damaged.

The capacity plate is placed on the front cover and the rating plate is on the inverter. Since these plates have the same serial numbers, always reinstall the removed cover onto the original inverter.

Using an external power supply

● Sink logic type

Use terminal PC as a common terminal to prevent a malfunction caused by undesirable current. (Do not connect terminal SD of the inverter with terminal 0V of the external power supply. When using terminals PC-SD as a 24V DC power supply, do not install a power supply in parallel in the outside of the inverter. Doing so may cause a malfunction due to undesirable current.)

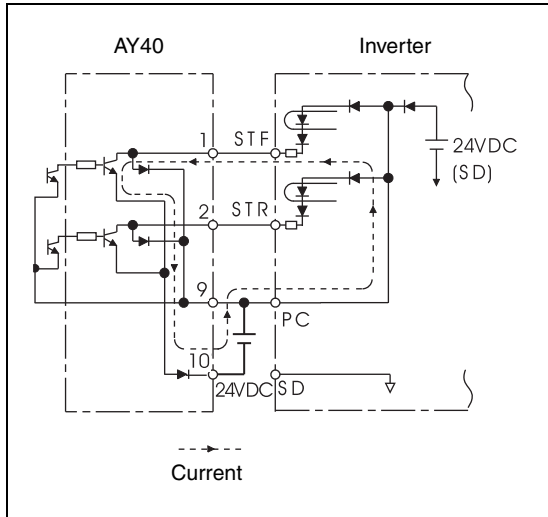

Fig. 3-12:

Using an external power supply in connection with the outputs of a PLC

1001030E

● Source logic type

When using an external power supply for transistor output, use terminal SD as a common to prevent misoperation caused by undesirable current.

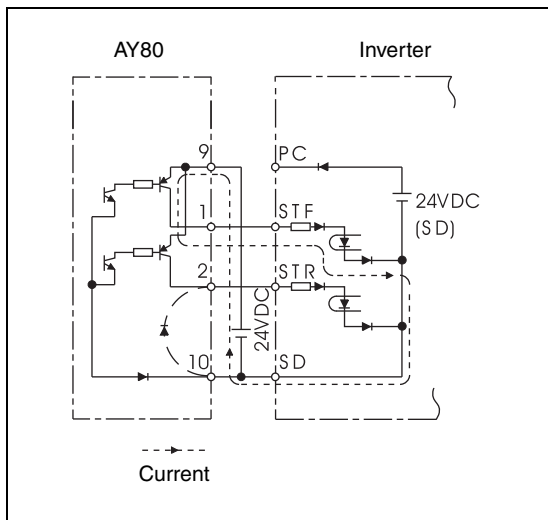

Fig. 3-13:

Using an external power supply in connection with the outputs of a PLC

1001031E

3.5 PU connector

Using the PU connector, you can perform communication operation from the FR-PU07, the FR-PA07 or a personal computer. Refer to the figure below to open the PU connector cover.

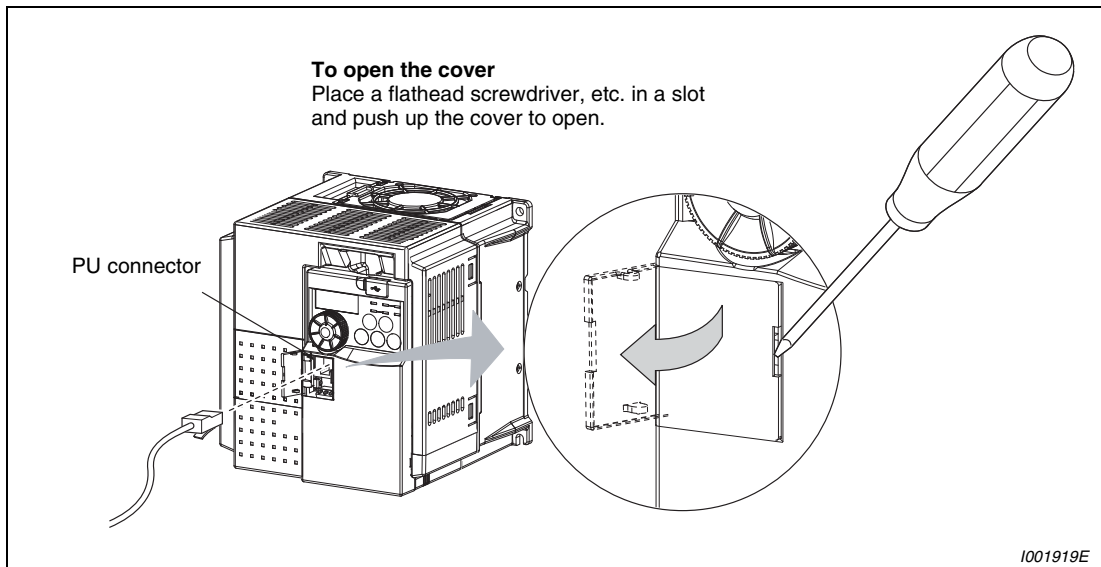

Fig. 3-14: To open the cover of the PU connector

3.5.1 Connecting the parameter unit using a connection cable

Use the optional FR-CB□□ or connector and cable available on the market. Insert the cable plugs securely into the PU connector of the inverter and the connection connector of the FR-PU07/FR-PA07 along the guide until the tabs snap into place.

Overall wiring length when the parameter unit is connected: max. 20m.

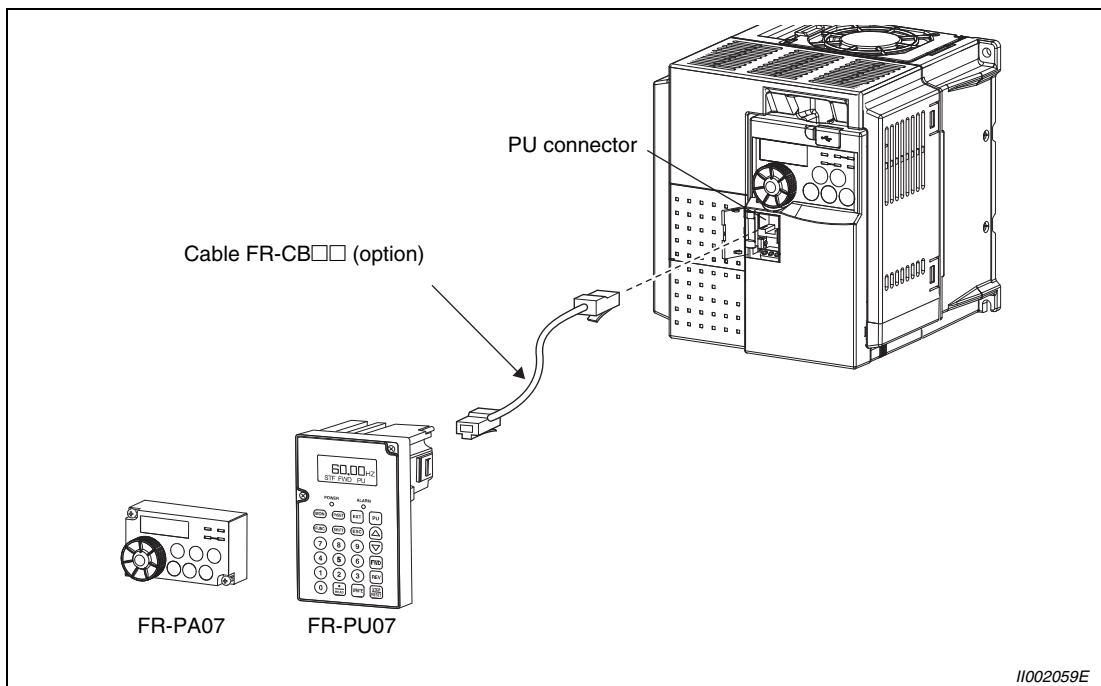

Fig. 3-15: Connecting the parameter unit FR-PU07/FR-PA07 using a connection cable

3.5.2 RS-485 communication

When the PU connector is connected with a personal, FA or other computer by a communication cable, a user program can run and monitor the inverter or read and write to parameters.

The protocol can be selected from Mitsubishi inverter and Modbus RTU. For detailed information refer to section 6.19.

3.6 USB connector

Inverter setup can be easily performed using the FR Configurator by connecting the inverter and personal computer with a USB cable (version 1.1).

| Specification | Description |
|--------------------|---|
| Interface | USB 1.1 |
| Transmission speed | 12MBps |
| Wiring length | 5m |
| Connector | USB mini B connector (receptacle mini B type) |
| Power supply | Self-power supply |

Tab. 3-13: USB connector specifications

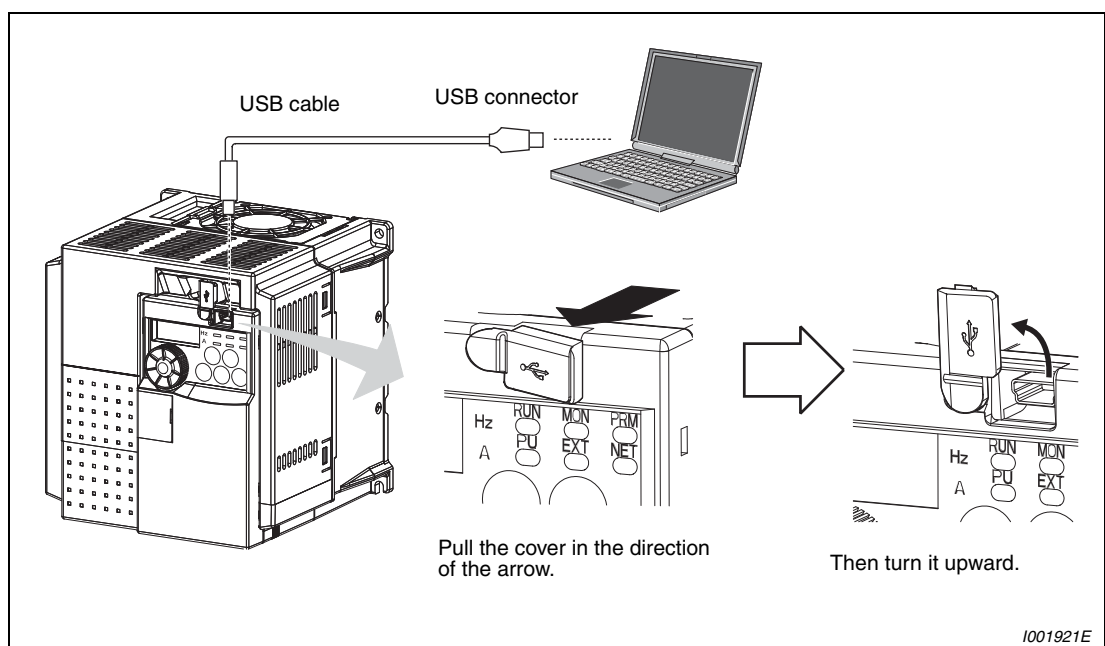

Fig. 3-16: Connection to the USB connector

3.7 Connection of stand-alone option units

The inverter accepts a variety of stand-alone option units as required.

**CAUTION:**

Incorrect connection will cause inverter damage or accident. Connect and operate the option unit carefully in accordance with the corresponding option unit manual.

3.7.1 Magnetic contactors (MC)

Inverter input side magnetic contactor (MC)

On the inverter input side, it is recommended to provide an MC for the following purposes.

- To release the inverter from the power supply when the fault occurs or when the drive is not functioning (e.g. emergency stop operation).
When cycle operation or heavy-duty operation is performed with an optional brake resistor connected, overheat and burnout of the discharging resistor can be prevented if a regenerative brake transistor is damaged due to insufficient heat capacity of the discharging resistor and excess regenerative brake duty.
- To prevent any accident due to an automatic restart at restoration of power after an inverter stop made by a power failure.
- The control power supply for inverter is always running and consumes a little power. When stopping the inverter for an extended period of time, powering off the inverter will save power slightly.
- To separate the inverter from the power supply to ensure safe maintenance and inspection work.

NOTE

Since repeated inrush currents at power on will shorten the life of the converter circuit (switching life is about 1,000,000 times.), frequent starts and stops of the MC must be avoided. Turn on/off the inverter start controlling terminals (STF, STR) to run/stop the inverter.

Example ▾

As shown below, always use the start signal (ON or OFF across terminals STF or STR-PC) to make a start or stop. (Refer to section 6.10.4.)

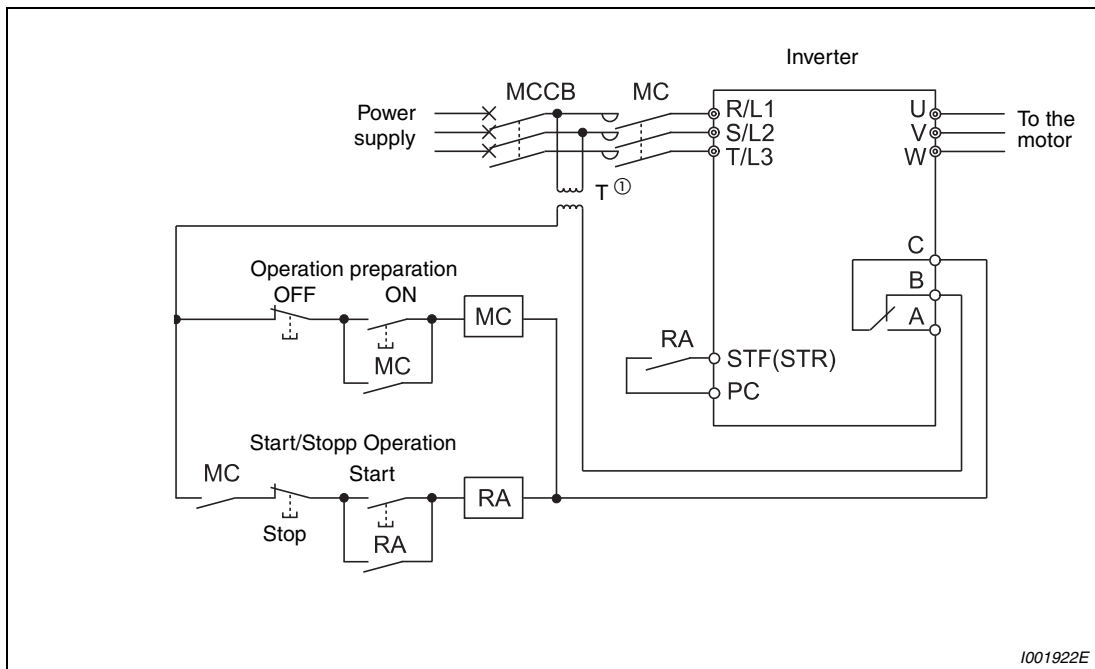

Fig. 3-17: Start and stop of the inverter

① When the power supply is 400V class, install a step-down transformer.



Handling of the inverter output side magnetic contactor

Switch the magnetic contactor between the inverter and motor only when both the inverter and motor are at a stop. When the magnetic contactor is turned on while the inverter is operating, overcurrent protection of the inverter and such will activate. When an MC is provided for switching to the commercial power supply, for example, switch it on/off after the inverter and motor have stopped.

3.7.2 Connection of a dedicated external brake resistor FR-ABR and MRS (FR-E720S-030 or more, FR-E740-016 or more)

Install a dedicated brake resistor (FR-ABR or MRS) outside when the motor is made to run by the load, quick deceleration is required, etc. Connect a dedicated brake resistor (FR-ABR or MRS) to terminal + and PR. (For the locations of terminal + and PR, refer to the terminal block layout (section 3.3.2).)

Set parameters below (refer to section 6.9.2).

| Connected brake resistor | Parameter setting | | |
|--------------------------|--|---|--------|
| | Pr. 30 „Regenerative function selection“ | Pr. 70 „Special regenerative brake duty“ | |
| MRS | 0 (initial value) | — | |
| FR-ABR | 1 | FR-E720S-110 or less FR-E740-170 or less | 10 (%) |
| | | FR-E740-230 or more | 6 (%) |

Tab. 3-14: Setting of parameter 30 and 70 when connecting an external brake resistor



CAUTION:

- The brake resistor connected should only be the dedicated brake resistor.
- Do not remove a jumper across terminal + and P1 except when connecting a DC reactor.
- The shape of jumper differs according to capacities.

FR-E720S-030

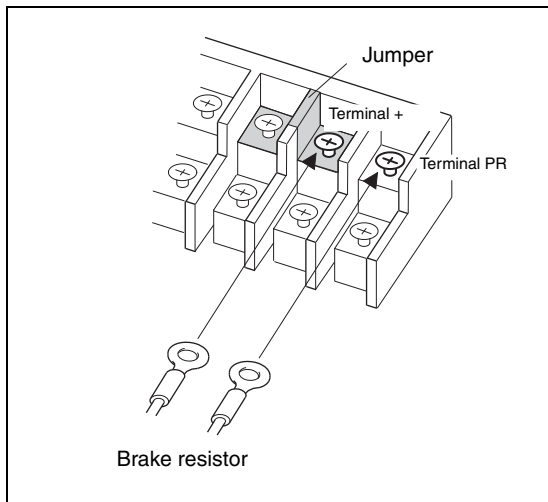

Fig. 3-18: Connection of a brake resistor to the terminals + and PR for the inverter FR-E720S-030

1002036E

FR-E720S-050 to 110 and FR-E740-016 to 095

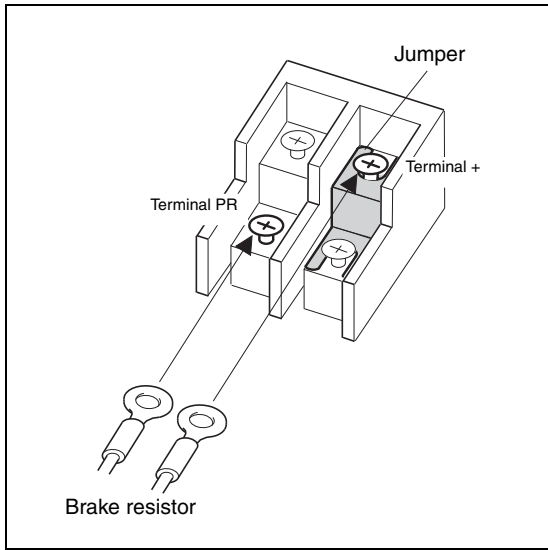

Fig. 3-19:
Connection of a brake resistor to the terminals + and PR for the inverters FR-E720S-050 to 110 and FR-E740-016 to FR-E740-095

I001923E

FR-E740-120 to 300

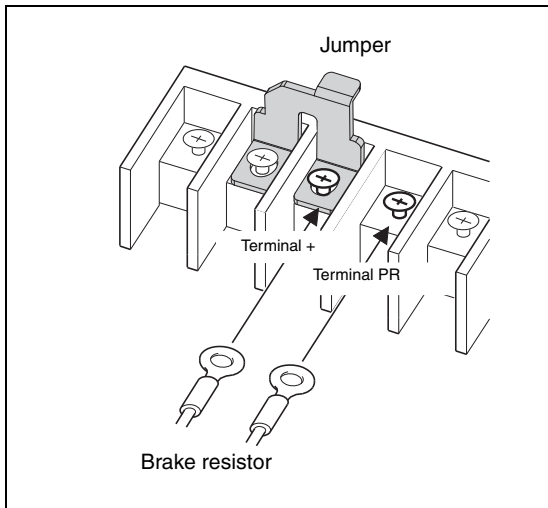

Fig. 3-20:
Connection of a brake resistor to the terminals + and PR for the inverters FR-E740-120 to FR-E740-300

I001924E

It is recommended to configure a sequence, which shuts off power in the input side of the inverter by the external thermal relay as shown below, to prevent overheat and burnout of the high duty brake resistor (FR-ABR) in case the regenerative brake transistor is damaged. (The brake resistor can not be connected to the FR-E720S-008 or 015.)

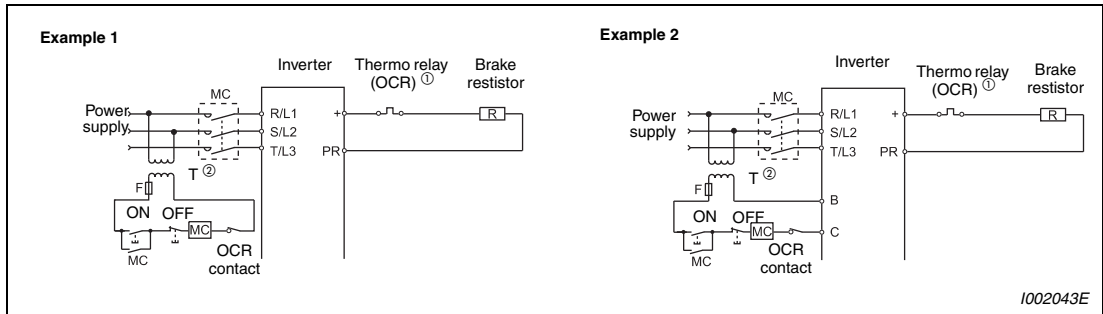

Fig. 3-21: Protection circuits

- ① Refer to Tab. 3-15 for the type number of each capacity of thermal relay and the diagram for the connection.
- ② When the power supply is 400V class, install a step-down transformer.

| Power Supply Voltage | Type | High-duty Brake Resistor | Thermal Relay Type (Mitsubishi Product) | Contact Rating |
|----------------------|--------|--------------------------|---|--|
| 230V | MRS | MRS120W200 | TH-N20CXHZKP-0.7A | 110V AC/5A 220V AC/2A (AC 11 class), 110V DC/0.5A 220V DC/0.25A (DC 11 class) |
| | | MRS120W100 | TH-N20CXHZKP-1.3A | |
| | | MRS120W60 | TH-N20CXHZKP-2.1A | |
| | | MRS120W40 | TH-N20CXHZKP-3.6A | |
| 400V | FR-ABR | FR-ABR-0.4K | TH-N20CXHZKP-0.7A | |
| | | FR-ABR-0.75K | TH-N20CXHZKP-1.3A | |
| | | FR-ABR-2.2K | TH-N20CXHZKP-2.1A | |
| | | FR-ABR-H0.4K | TH-N20CXHZKP-0.24A | |
| | | FR-ABR-H0.75K | TH-N20CXHZKP-0.35A | |
| | | FR-ABR-H1.5K | TH-N20CXHZKP-0.9A | |
| | | FR-ABR-H2.2K | TH-N20CXHZKP-1.3A | |
| | | FR-ABR-H3.7K | TH-N20CXHZKP-2.1A | |
| | | FR-ABR-H5.5K | TH-N20CXHZKP-2.5A | |
| | | FR-ABR-H7.5K | TH-N20CXHZKP-3.6A | |
| | | FR-ABR-H11K | on request | |
| | | FR-ABR-H15K | on request | |

Tab. 3-15: Resistor and thermal relay combination

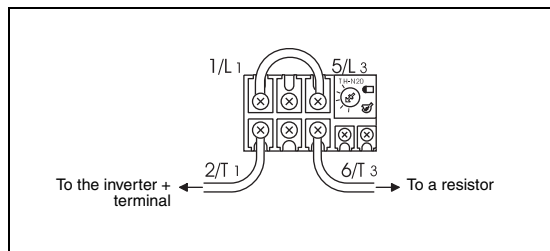

Fig. 3-22: Connecting the thermal relay

I001458E

**CAUTION:**

- *Brake resistor can not be used with the brake unit (FR-BU2), high power factor converter (FR-HC), power supply regeneration converter (FR-CV), etc.*
- *Do not connect a resistor directly to the DC terminals + and -. This could cause a fire.*

3.7.3 Connection of a brake unit FR-BU2

When connecting a brake unit to improve the brake capability at deceleration, make connection as shown below.

Connection example with the GRZG type discharging resistor

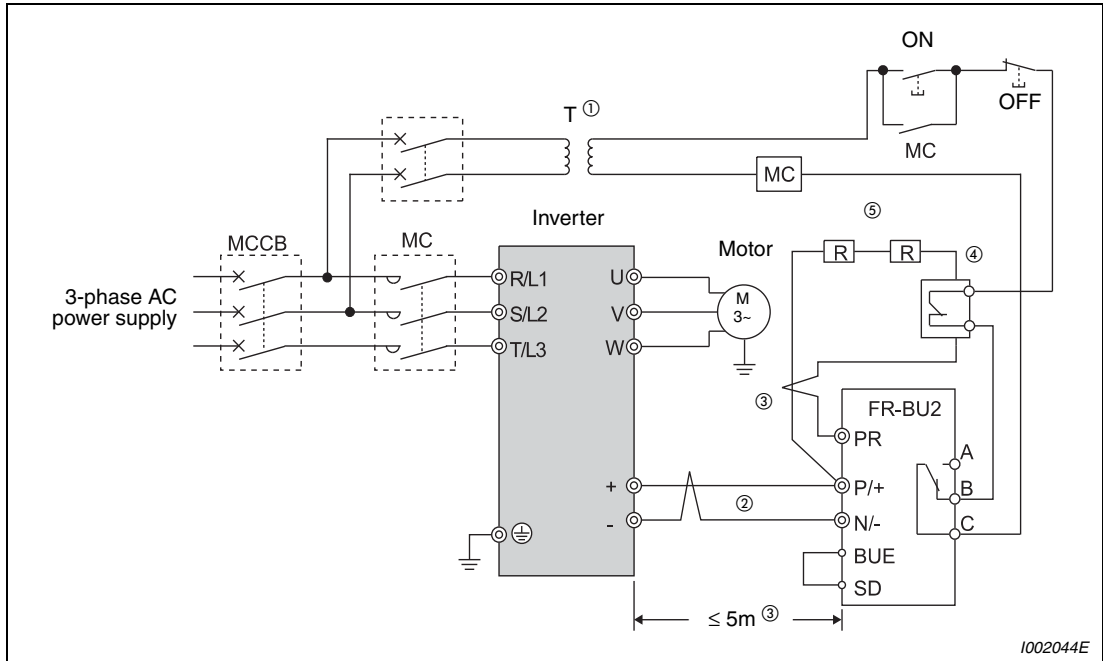

Fig. 3-23: Connection with the brake unit FR-BU2

- ① If the control contacts are only specified for 230V control power you must install a transformer when using a 400V power supply.
- ② Connect the inverter terminals (+, -) and brake unit terminals so that their terminal signals match with each other. (Incorrect connection will damage the inverter.)
- ③ The wiring distance between the inverter, brake unit and resistor unit should be within 5m. If twisted wires are used, the distance should be within 10m.
- ④ If the transistors in the brake unit should become faulty, the resistor can be unusually hot, causing a fire. Therefore, install a magnetic contactor on the inverters input side to configure a circuit so that a current is shut off in case of fault.
- ⑤ Refer to FR-BU2 manual for connection method of discharging resistor.

| Brake Unit | Discharging Resistor | Recommended External Thermal Relay |
|-------------|--------------------------------|------------------------------------|
| FR-BU2-1.5K | GZG 300W-50Ω (one) | TH-N20CXHZKP-1.3A |
| FR-BU2-3.7K | GRZG 200-10Ω (three in series) | TH-N20CXHZKP-3.6A |
| FR-BU2-7.5K | GRZG 300-5Ω (four in series) | on request |
| FR-BU2-15K | GRZG 400-2Ω (six in series) | on request |
| FR-BU2-7.5K | GRZG 200-10Ω (six in series) | TH-N20CXHZKP-3.6A |
| FR-BU2-15K | GRZG 300-5Ω (eight in series) | on request |

Tab. 3-16: Recommended external relay

**CAUTION:**

- *If the transistors in the brake unit should become faulty, the resistor can be unusually hot, causing a fire. Therefore, install a magnetic contactor on the inverters input side to configure a circuit so that a current is shut off in case of fault.*
- *Do not remove a jumper across terminal + and P1 except when connecting a DC reactor.*

NOTE

Set "1" in Pr. 0 "Brake mode selection" of the FR-BU2 to use GRZG type discharging resistor.

Connection example with the FR-BR(-H) type resistor

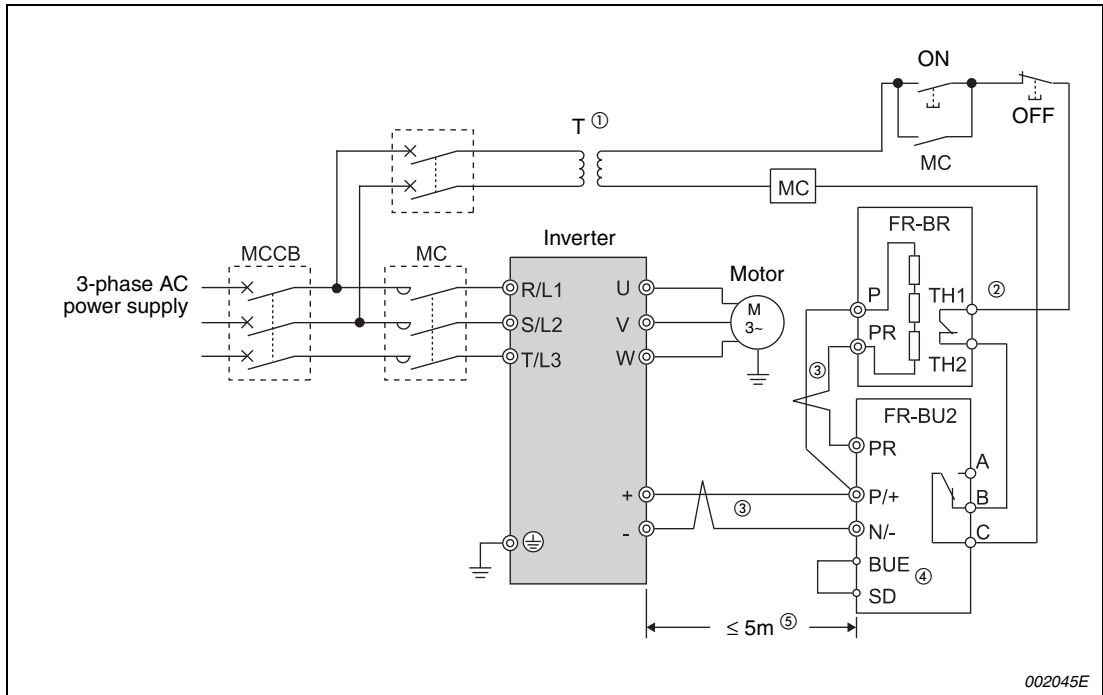

Fig. 3-24: Connection with the brake unit FR-BU2

- ① If the control contacts are only specified for 230V control power you must install a transformer when using a 400V power supply.
- ② Normal: across TH1-TH2 ... close, Alarm: across TH1-TH2 ... open
- ③ Connect the inverter terminals (+, -) and brake unit terminals so that their terminal signals match with each other. (Incorrect connection will damage the inverter.)
- ④ A jumper is connected across BUE and SD in the initial status.
- ⑤ The wiring distance between the inverter, brake unit and resistor unit should be within 5m. If twisted wires are used, the distance should be within 10m.



CAUTION:

- If the transistors in the brake unit should become faulty, the resistor can be unusually hot, causing a fire. Therefore, install a magnetic contactor on the inverters input side to configure a circuit so that a current is shut off in case of fault.
- Do not remove a jumper across terminal + and P1 except when connecting a DC reactor.

3.7.4 Connection of the high power factor converter FR-HC

When connecting the high power factor converter (FR-HC) to suppress power harmonics, perform wiring securely as shown below.



CAUTION:

Perform wiring of the high power factor converter (FR-HC) securely as shown below. Incorrect connection will damage the high power factor converter and inverter.

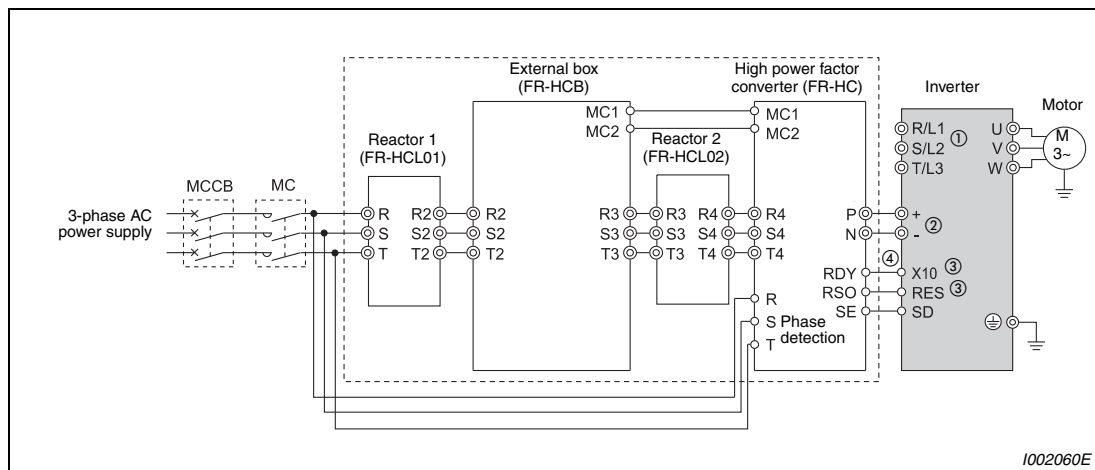

Fig. 3-25: Connection of the high power factor converter FR-HC

- ① Keep input terminals (R/L1, S/L2, T/L3) open. Incorrect connection will damage the inverter.
- ② Do not insert an MCCB between the terminals + and – (between P and +, between N and –). Opposite polarity of terminals –, + will damage the inverter.
- ③ Use Pr. 178 to Pr. 184 "Input terminal function selection" to assign the terminals used for the X10, RES signal. (Refer to section 6.10).
- ④ Be sure to connect terminal RDY of the FR-HC to the X10 signal or MRS signal assigned terminal of the inverter, and connect terminal SE of the FR-HC to terminal SD of the inverter. Without proper connecting, FR-HC will be damaged.

NOTES

The voltage phases of terminals R/L1, S/L2, T/L3 and terminals R4, S4, T4 must be matched.

Use sink logic when the FR-HC is connected. The FR-HC cannot be connected when source logic (factory setting) is selected.

Do not remove a jumper across terminal + and P1 except when connecting a DC reactor.

3.7.5 Connection of the power regeneration common converter FR-CV

When connecting the power regeneration common converter (FR-CV), make connection so that the inverter terminals (+, -) and the terminal symbols of the power regeneration common converter (FR-CV) are the same.

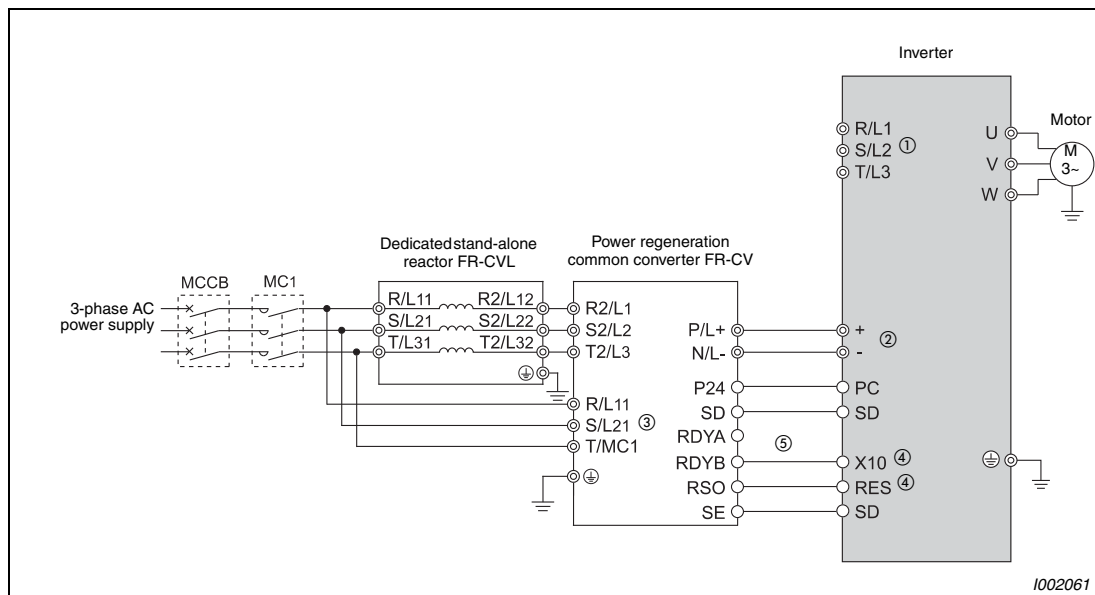

Fig. 3-26: Connection of the power regeneration common converter FR-CV

- ① Always keep the power input terminals R/L1, S/L2, T/L3 open. Incorrect connection will damage the inverter.
- ② Do not insert an MCCB between the terminals + and - (between P/L+ and +, between N/L- and -). Opposite polarity of terminals -, + will damage the inverter.
- ③ Always connect the power supply and terminals R/L11, S/L21, T/MC1. Operating the inverter without connecting them will damage the power regeneration common converter.
- ④ Use Pr. 178 to Pr. 184 "Input terminal function selection" to assign the terminals used for the X10, RES signal. (Refer to section 6.10).
- ⑤ Be sure to connect terminal RDYB of the FR-CV to the X10 signal or MRS signal assigned terminal of the inverter, and connect terminal SE of the FR-CV to terminal SD of the inverter. Without proper connecting, FR-CV will be damaged.

NOTES

- | The voltage phases of terminals R/L11, S/L21, T/MC1 and terminals R2/L1, S2/L2, T2/L3 must be matched.
- | Use sink logic when the FR-CV is connected. The FR-CV cannot be connected when source logic (factory setting) is selected.
- | Do not remove a jumper across terminal + and P1.

3.7.6 Connection of the power improving DC reactor FFR-HEL-(H)-E

When using the DC reactor (FFR-HEL-(H)-E), connect it between terminals P1 and +. In this case, the jumper connected across terminals P1 and + must be removed. Otherwise, the reactor will not exhibit its performance.

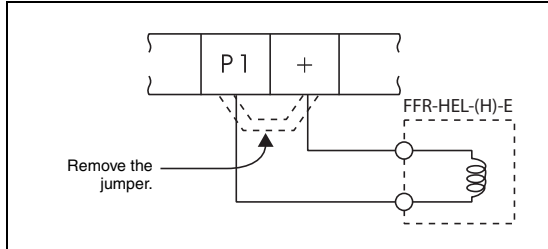

Fig. 3-27:
Connection of a DC reactor

I002048E_N

NOTES

The wiring distance should be within 5m.

The size of the cables used should be equal to or larger than that of the power supply cables (R/L1, S/L2, T/L3).

3.7.7 Installation of a reactor

When the inverter is connected near a large-capacity power transformer (500kVA or more) or when a power capacitor is to be switched over, an excessive peak current may flow in the power input circuit, damaging the converter circuit. To prevent this, always install the optional DC reactor (FFR-HEL-(H)-E) or AC reactor (FR-BAL-B).

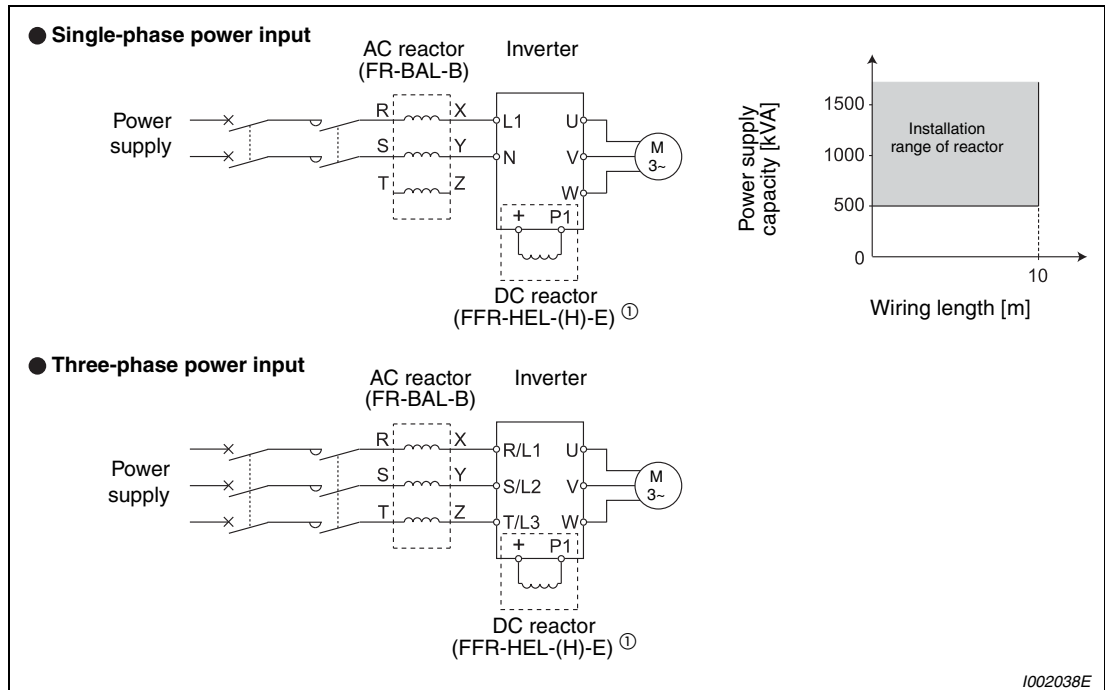

I002038E

Fig. 3-28: Installation of a reactor

① When connecting the FFR-HEL-(H)-E, remove the jumper across terminals + and P1.

NOTES

The wiring length between the FFR-HEL-(H)-E and inverter should be 5m maximum and minimized.

Use the same wire size as that of the power supply wire (R/L1, S/L2, T/L3). (Refer to page 3-9.)

3.8 Electromagnetic compatibility (EMC)

3.8.1 Leakage currents and countermeasures

Mains filters, shielded motor cables, the motor, and the inverter itself cause stationary and variable leakage currents to PE. Since its value depends on the capacitances, carrier frequency, etc., low acoustic noise operation at the increased carrier frequency of the inverter will increase the leakage current. Therefore, take the following measures. Select the earth leakage breaker according to its rated sensitivity current, independently of the carrier frequency setting.

To-earth (ground) leakage currents

Leakage currents may flow not only into the inverter's own line but also into the other lines through the earth (ground) cable, etc. These leakage currents may operate earth (ground) leakage circuit breakers and earth leakage relays unnecessarily.

- Countermeasures

- If the carrier frequency setting is high, decrease the Pr. 72 "PWM frequency selection" setting. Note that motor noise increases. Selecting Pr. 240 "Soft-PWM operation selection" makes the sound inoffensive.
- By using earth leakage circuit breakers designed for harmonic and surge suppression in the inverter's own line and other line, operation can be performed with the carrier frequency kept high (with low noise).

- To-earth leakage currents

- Take caution as long wiring will increase the leakage current. Decreasing the carrier frequency of the inverter reduces the leakage current.
- Increasing the motor capacity increases the leakage current.
- Shielded motor cables significantly increase the leakage current to PE (approx. double the value generated with unshielded motor cables of the same length).
- The leakage current of the 400V class is larger than that of the 200V class.

Line-to-line leakage currents

Harmonics of leakage currents flowing in static capacities between the inverter output cables may operate the external thermal relay unnecessarily. When the wiring length is long (50m or more) for the 400V class small-capacity model (FR-E700-170 or less), the external thermal relay is likely to operate unnecessarily because the ratio of the leakage current to the rated motor current increases.

Example ▾

Line-to-line leakage current data example

Dedicated motor: SF-JR 4P

Carrier frequency: 14.5kHz

Used wire: 2mm², 4 cores, cab tyre cable

| Motor Capacity [kW] | Rated Motor Current [A] | Leakage Currents [mA] | |
|---------------------|-------------------------|-----------------------|--------------------|
| | | Wiring length 50m | Wiring length 100m |
| 0.4 | 1.1 | 620 | 1000 |
| 0.75 | 1.9 | 680 | 1060 |
| 1.5 | 3.5 | 740 | 1120 |
| 2.2 | 4.1 | 800 | 1180 |
| 3.7 | 6.4 | 880 | 1260 |
| 5.5 | 9.7 | 980 | 1360 |
| 7.5 | 12.8 | 1070 | 1450 |

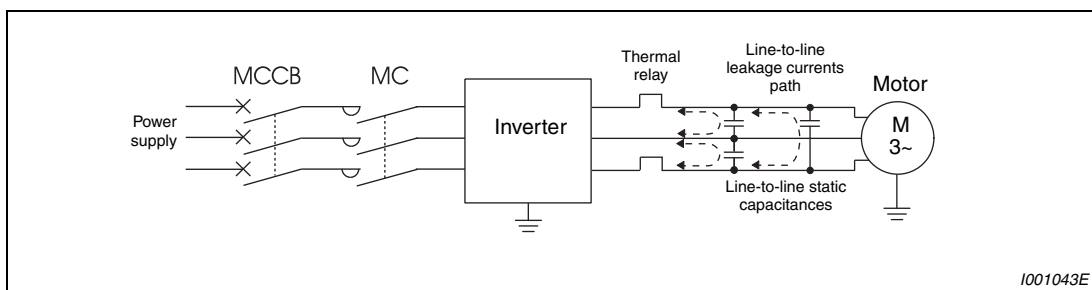
Tab. 3-17: Line-to-line leakage current data example**Fig. 3-29:** Line-to-line leakage currents

● Countermeasures

- Use Pr. 9 "Electronic thermal O/L relay".
- If the carrier frequency setting is high, decrease the Pr. 72 "PWM frequency selection" setting. Note that motor noise increases. Selecting Pr. 240 "Soft-PWM operation selection" makes the sound inoffensive. To ensure that the motor is protected against line-to-line leakage currents, it is recommended to use a temperature sensor (e.g. PTC element) to directly detect motor temperature.

● Selecting a power supply circuit breaker:

You can also use a circuit breaker (MCCB) to protect the power supply lines against short circuits and overloads. However, note that this does not protect the inverter (rectifiers, IGBT). Select the capacity of the circuit breaker on the basis of the cross-sectional area of the power supply lines. To calculate the required mains current trip point you need to know the power required by the inverter (Refer to Rated Input Capacity in Appendix A, Specifications) and the mains supply voltage. Select a circuit breaker with a trip point that is slightly higher than calculated, particularly in the case of breakers with electromagnetic tripping, since the trip characteristics are strongly influenced by the harmonics in the power supply line.

NOTE

The earth leakage breaker must be either a Mitsubishi earth leakage breaker (ELB, for harmonics and surges) or an ELB with breaker designed for harmonic and surge suppression that is approved for use with frequency inverters.

Note on selecting a suitable power supply ELCB

If you install a Mitsubishi frequency inverter with a 3-phase power supply in locations where an earth leakage contact breaker is required by the VDE you must install a universal-current sensitive ELCB conforming to the specifications laid down in VDE 0160 / EN 50178 (ELCB Type B). This is necessary because pulse-current sensitive ELCBs (Type A) do not provide reliable tripping performance for the frequency inverter in response to DC leakage current.

When selecting a suitable universal-current sensitive ELCB you must also take into account the influence of the mains filter, the length of the shielded motor power cables and the frequency on the leakage currents.

Also note that when the mains power is switched on with switches without a snap-action function the resulting brief asymmetrical load can cause unwanted triggering of the ELCB.

This problem can be avoided by using a Type B ELCB with a delayed response function, or by using a contactor relay to switch all three phases simultaneously.

Calculate the trip current sensitivity of the ELB as follows:

- Breaker designed for harmonic and surge suppression:

$$\Delta n \geq 10 \times (I_{g1} + I_{gn} + I_{gi} + I_{g2} + I_{gm})$$
- Standard breaker:

$$\Delta n \geq 10 \times [I_{g1} + I_{gn} + I_{gi} + 3 \times (I_{g2} + I_{gm})]$$

I_{g1}, I_{g2}: Leakage currents in wire path during commercial power supply operation

I_{gn}: Leakage current of inverter input side noise filter

I_{gm}: Leakage current of motor during commercial power supply operation

I_{gi}: Leakage current of inverter unit

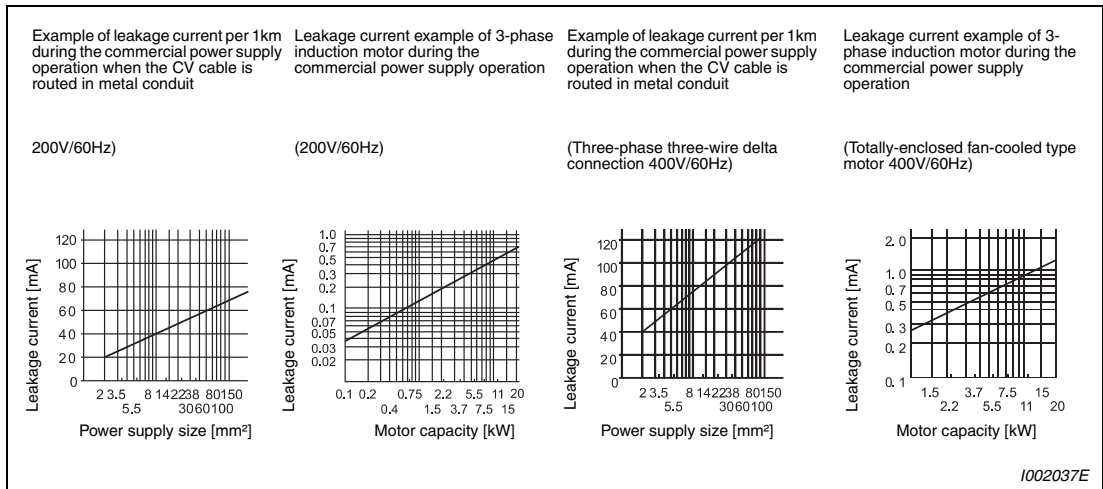
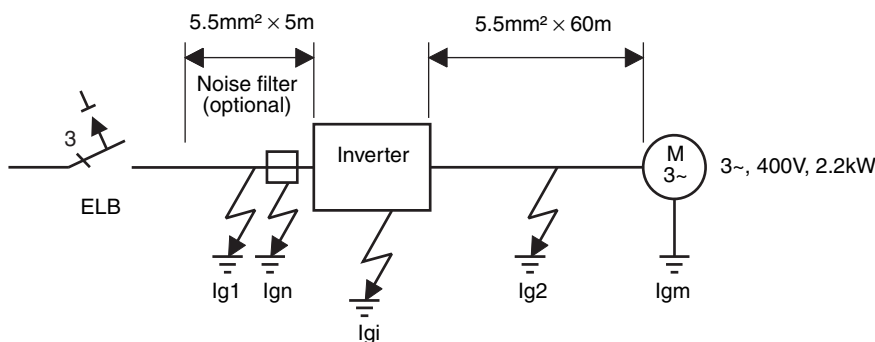

Fig. 3-30: Leakage currents

NOTE

For star connection, the amount of leakage current is 1/3.

Example ▽



| | Breaker Designed for Harmonic and Surge Suppression | Standard Breaker |
|--------------------------------|---|------------------|
| Leakage current Ig1 [mA] | $\frac{1}{3} \times 66 \times \frac{5 \text{ m}}{1000 \text{ m}} = 0.11$ | |
| Leakage current Ign [mA] | 0 (without noise filter) | |
| Leakage current Igi [mA] | 1 (with noise filter) | |
| Leakage current Ig2 [mA] | $\frac{1}{3} \times 66 \times \frac{60 \text{ m}}{1000 \text{ m}} = 1.32$ | |
| Motor leakage current Igm [mA] | 0.36 | |
| Total leakage current [mA] | 2.79 | 6.15 |
| Rated sensitivity current [mA] | 30 | 100 |

Tab. 3-18: Estimation of the permanent flowing leakage current



NOTES

The frequency inverter monitors its own output for ground faults up to a frequency of 120Hz. However, it is important to understand that this feature only protects the inverter itself. It cannot be used to provide protection against shock hazards for personnel.

In the connection earthed-neutral system, the sensitivity current is purified against an earth fault in the inverter output side. Earthing must conform to the requirements of national and local safety regulations and electrical codes. (JIS, NEC section 250, IEC 536 class 1 and other applicable standards)

When the breaker is installed on the output side of the inverter, it may be unnecessarily operated by harmonics even if the effective value is less than the rating. In this case, do not install the breaker since the eddy current and hysteresis loss will increase, leading to temperature rise.

The following models are standard breakers: BV-C1, BC-V, NVB, NV-L, NV-G2N, NV-G3NA and NV-2F earth leakage relay (except NV-ZHA), NV with AA neutral wire open-phase protection.

The other models are designed for harmonic and surge suppression: NV-C/NV-S/MN series, NV30-FA, NV50-FA, BV-C2, earth leakage alarm breaker (NF-Z), NV-ZHA, NV-H

3.8.2 Inverter-generated noises and their reduction techniques

Some noises enter the inverter to malfunction it and others are radiated by the inverter to malfunction peripheral devices. Though the inverter is designed to be insusceptible to noises, it handles low-level signals, so it requires the following basic techniques. Also, since the inverter chops outputs at high carrier frequency, that could generate noises. If these noises cause peripheral devices to malfunction, measures should be taken to suppress noises.

These techniques differ slightly depending on noise propagation paths.

- Basic techniques

- Do not run the power cables (I/O cables) and signal cables of the inverter in parallel with each other and do not bundle them.
- Use twisted pair shielded cables for the detector connection and control signal cables. Earth the shield.
- Earth the inverter, motor, etc. at one point.

- Techniques to reduce noises that enter and malfunction the inverter

When devices that generate many noises (which use magnetic contactors, magnetic brakes, many relays, for example) are installed near the inverter and the inverter may be malfunctioned by noises, the following measures must be taken:

- Provide surge suppressors for devices that generate many noises to suppress noises.
- Fit data line filters to signal cables.
- Earth the shields of the detector connection and control signal cables with cable clamp metal.

- Techniques to reduce noises that are radiated by the inverter to malfunction peripheral devices

Inverter-generated noises are largely classified into:

- those radiated by the cables connected to the inverter and inverter main circuits (I/O),
- those electromagnetically and electrostatically induced to the signal cables of the peripheral devices close to the main circuit power supply,
- and those transmitted through the power supply cables.

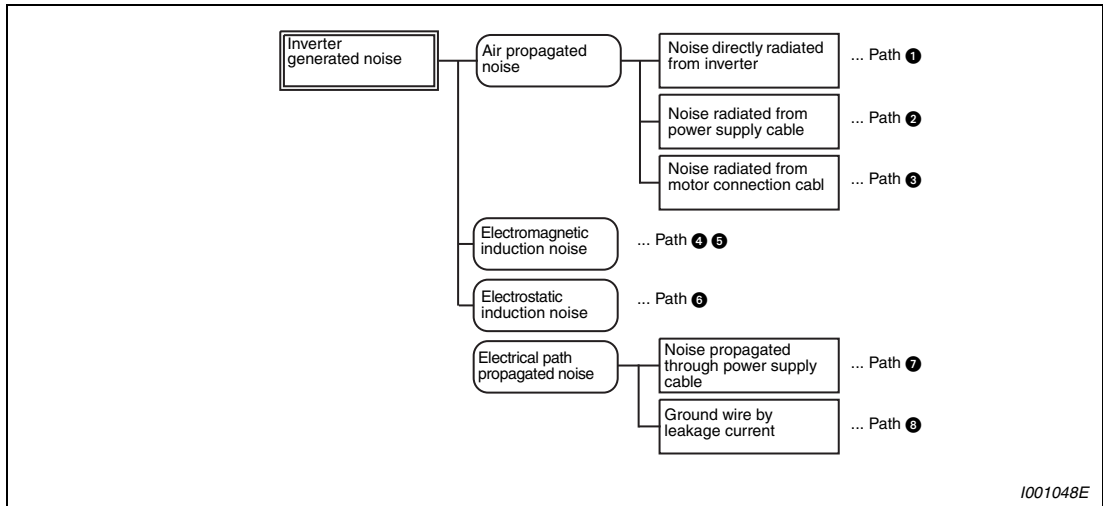

Fig. 3-31: Noise propagation

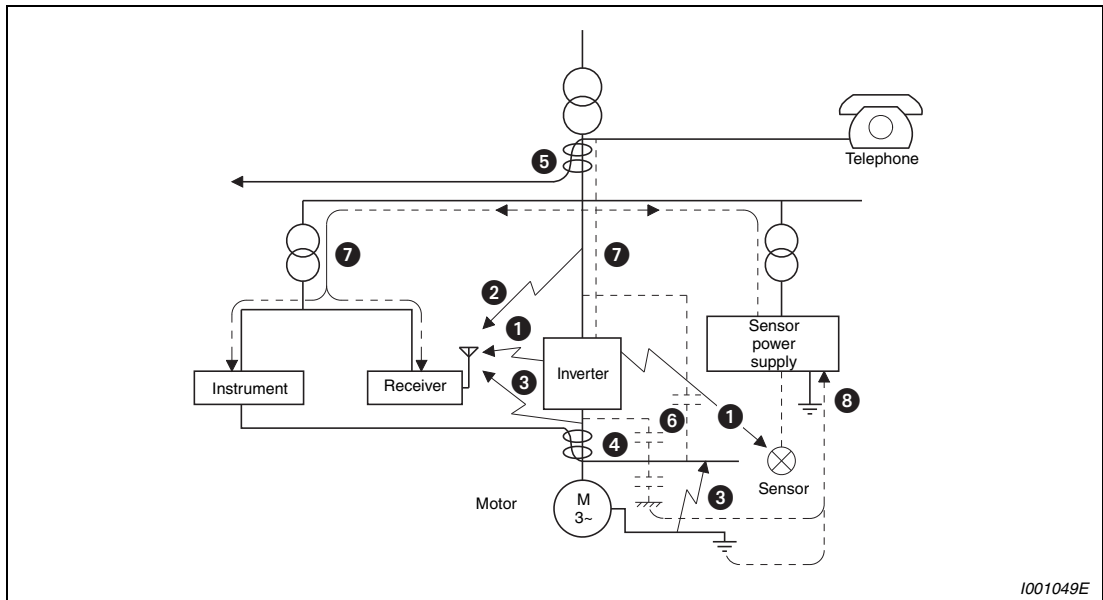

Fig. 3-32: Noise paths

| Noise Propagation Path | Measures |
|------------------------|---|
| 1 2 3 | <p>When devices that handle low-level signals and are liable to malfunction due to noises, e.g. instruments, receivers and sensors, are contained in the enclosure that contains the inverter or when their signal cables are run near the inverter, the devices may be malfunctioned by air-propagated noises. The following measures must be taken:</p> <ul style="list-style-type: none"> • Install easily affected devices as far away as possible from the inverter. • Run easily affected signal cables as far away as possible from the inverter and its I/O cables. • Do not run the signal cables and power cables (inverter I/O cables) in parallel with each other and do not bundle them. • Inserting a filter (dU/dt, sine wave filter) into the output suppresses the radiation noise from the cables. • Use shield cables as signal cables and power cables and run them in individual metal conduits to produce further effects. |
| 4 5 6 | <p>When the signal cables are run in parallel with or bundled with the power cables, magnetic and static induction noises may be propagated to the signal cables to malfunction the devices and the following measures must be taken:</p> <ul style="list-style-type: none"> • Install easily affected devices as far away as possible from the inverter. • Run easily affected signal cables as far away as possible from the I/O cables of the inverter. • Do not run the signal cables and power cables (inverter I/O cables) in parallel with each other and do not bundle them. • Use shield cables as signal cables and power cables and run them in individual metal conduits to produce further effects. |
| 7 | <p>When the power supplies of the peripheral devices are connected to the power supply of the inverter in the same line, inverter-generated noises may flow back through the power supply cables to malfunction the devices and the following measures must be taken:</p> <ul style="list-style-type: none"> • Use additional (optional) noise filters as required. • Install output filters to the power cables of the inverter after you consulted MITSUBISHI. |
| 8 | <p>When a closed loop circuit is formed by connecting the peripheral device wiring to the inverter, leakage currents may flow through the earth cable of the inverter to malfunction the device. In such a case, disconnection of the earth cable of the device may cause the device to operate properly.</p> |

Tab. 3-19: Noise and Countermeasures

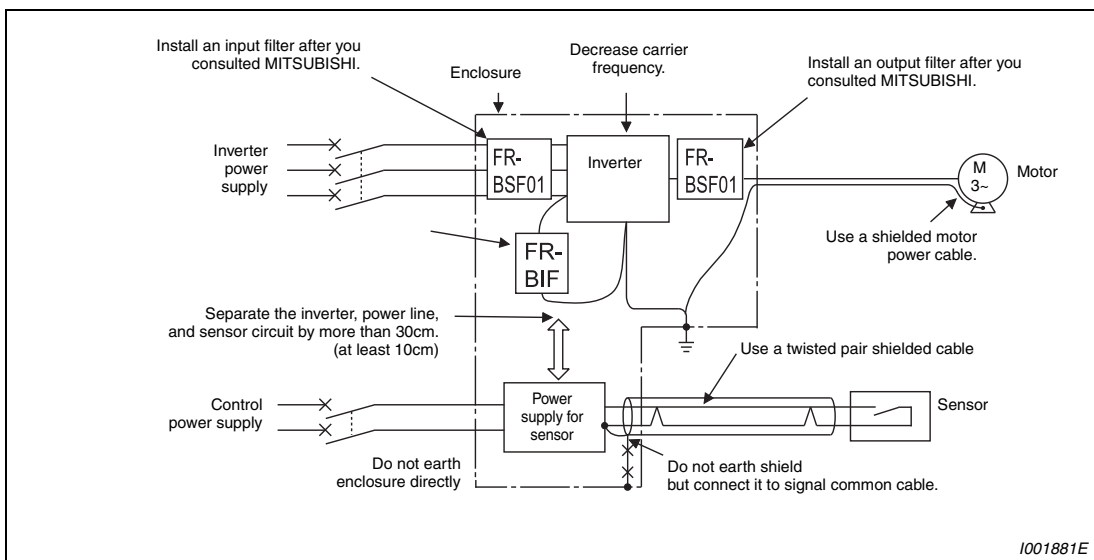

Fig. 3-33: Noise reduction examples

3.8.3 Power supply harmonics

The inverter may generate power supply harmonics from its converter circuit to affect the power generator, power capacitor etc. Power supply harmonics are different from noise and leakage currents in source, frequency band and transmission path. Take the following countermeasure suppression techniques.

| Item | Harmonics | Noise |
|-----------------------------|--------------------------------------|--|
| Frequency | Maximum 50 ($\leq 3\text{kHz}$) | Several 10kHz to 1GHz |
| Environment | To electric channel, power impedance | To-space, distance, wiring path |
| Quantitative understanding | Theoretical calculation possible | Random occurrence, quantitative grasping difficult |
| Generated amount | Nearly proportional to load capacity | Depending on the current fluctuation ratio (larger as switching is faster) |
| Affected equipment immunity | Specified in standard per equipment | Different depending on maker's equipment specifications |
| Suppression example | Provide reactor | Increase distance |

Tab. 3-20: Differences between harmonics and noises

● Measures

The harmonic current generated from the inverter to the input side differs according to various conditions such as the wiring impedance, whether a reactor is used or not, and output frequency and output current on the load side.

For the output frequency and output current, we understand that they should be calculated in the conditions under the rated load at the maximum operating frequency.

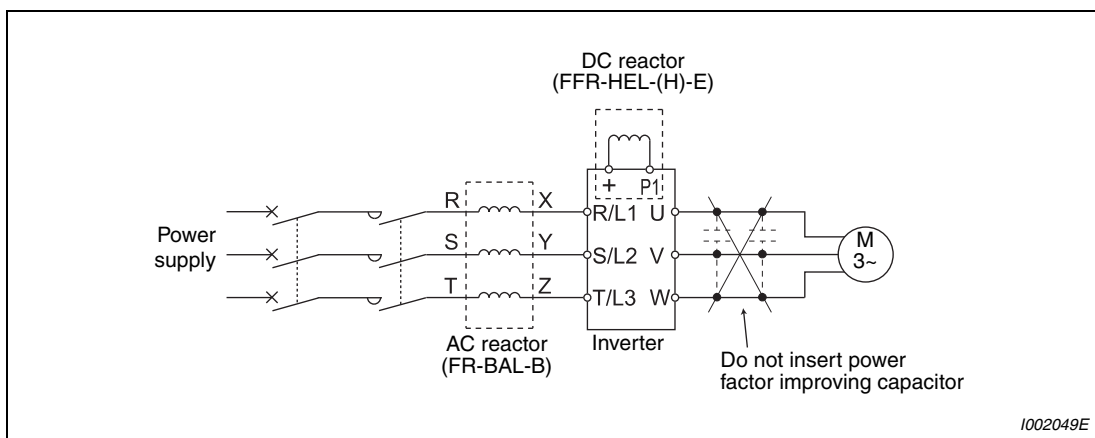

Fig. 3-34: Reduction of power supply harmonics



CAUTION:

The power factor improving capacitor and surge suppressor on the inverter output side may be overheated or damaged by the harmonic components of the inverter output. Also, since an excessive current flows in the inverter to activate over current protection, do not provide a capacitor and surge suppressor on the inverter output side when the motor is driven by the inverter. For power factor improvement, install a reactor on the inverter input side or in the DC circuit.

3.8.4 Inverter-driven 400V class motor

In the PWM type inverter, a surge voltage attributable to wiring constants is generated at the motor terminals. Especially for a 400V class motor, the surge voltage may deteriorate the insulation. When the 400V class motor is driven by the inverter, consider the following measures:

- Rectifying the motor insulation and limiting the PWM carrier frequency according to the wiring length. For the 400V class motor, use an insulation-enhanced motor.
 - Specify the "400V class inverter-driven insulation-enhanced motor".
 - For the dedicated motor such as the constant-torque motor and low-vibration motor, use the "inverter-driven, dedicated motor".
 - Set Pr. 72 "PWM frequency selection" as indicated below according to the wiring length.

| | Wiring Length | | |
|--------------|----------------|-------------|------------|
| | ≤ 50m | 50m to 100m | ≥ 100m |
| Parameter 72 | ≤ 15 (14.5kHz) | ≤ 8 (8kHz) | ≤ 2 (2kHz) |

Tab. 3-21: Setting of Pr. 72 according to the wiring length

- Limiting the voltage rise speed of the frequency inverter output voltage (dU/dT):
If the motor requires a rise speed of 500V/μs or less you must install a filter in the output of the inverter. Please contact your Mitsubishi dealer for more details.

NOTE

For details of Pr. 72 "PWM frequency selection", refer to section 6.15.

4 Operation

4.1 Precautions for use of the inverter

The FR-E700 series is a highly reliable product, but incorrect peripheral circuit making or operation/handling method may shorten the product life or damage the product.

Before starting operation, always recheck the following items.

- Use crimping terminals with insulation sleeve to wire the power supply and motor.
- Application of power to the output terminals (U, V, W) of the inverter will damage the inverter. Never perform such wiring.
- After wiring, wire offcuts must not be left in the inverter.
Wire offcuts can cause an alarm, failure or malfunction. Always keep the inverter clean. When drilling mounting holes in a control box etc., take care not to allow chips and other foreign matter to enter the inverter.
- Use cables of the size to make a voltage drop 2% maximum.
If the wiring distance is long between the inverter and motor, a main circuit cable voltage drop will cause the motor torque to decrease especially at the output of a low frequency. (Refer to page 3-9 for the recommended cable sizes.)
- The overall wiring length should be 500m maximum.
Especially for long distance wiring, the fast-response current limit function may be reduced or the equipment connected to the inverter output side may malfunction or become faulty under the influence of a charging current due to the stray capacity of the wiring. Therefore, note the overall wiring length. (Refer to page 3-12.)
- Electromagnetic Compatibility
Operation of the frequency inverter can cause electromagnetic interference in the input and output that can be propagated by cable (via the power input lines), by wireless radiation to nearby equipment (e.g. AM radios) or via data and signal lines.
Use AC or DC reactors to reduce line propagated noise (harmonics). Use shielded motor power lines to reduce output noise (refer also to section 3.8 Electromagnetic Compatibility).
- Do not install a power factor correction capacitor, surge suppressor or radio noise filter on the inverter output side. This will cause the inverter to trip or the capacitor and surge suppressor to be damaged. If any of the above devices is installed, immediately remove it.
- Before starting wiring or other work after the inverter is operated, wait for at least 10 minutes after the power supply has been switched off, and check that there are no residual voltage using a tester or the like. The capacitor is charged with high voltage for some time after power off and it is dangerous.
- A short circuit or earth fault on the inverter output side may damage the inverter modules.
 - Fully check the insulation resistance of the circuit prior to inverter operation since repeated short circuits caused by peripheral circuit inadequacy or an earth fault caused by wiring inadequacy or reduced motor insulation resistance may damage the inverter modules.
 - Fully check the to-earth insulation and inter-phase insulation of the inverter output side before power-on.
Especially for an old motor or use in hostile atmosphere, securely check the motor insulation resistance etc.

- Do not use the inverter input side magnetic contactor to start/stop the inverter. Always use the start signal (ON/OFF of STF and STR signals) to start/stop the inverter.
- Across + and PR terminals, connect only an external regenerative brake discharging resistor. Do not connect a mechanical brake. The brake resistor can not be connected to the FR-E720S-008 and 015. Leave terminals + and PR open. Also, never short between + and PR.
- Do not apply a voltage higher than the permissible voltage to the inverter I/O signal circuits. Contact to the inverter I/O signal circuits or opposite polarity may damage the I/O devices. Especially check the wiring to prevent the speed setting potentiometer from being connected incorrectly to short terminals 10-5.
- Provide electrical and mechanical interlocks for MC1 and MC2 which are used for commercial power supply-inverterswitch-over. When the wiring is incorrect or if there is a commercial power supply-inverter switch-over circuit as shown below, the inverter will be damaged by leakage current from the power supply due to arcs generated at the time of switch-over or chattering caused by a sequence error.

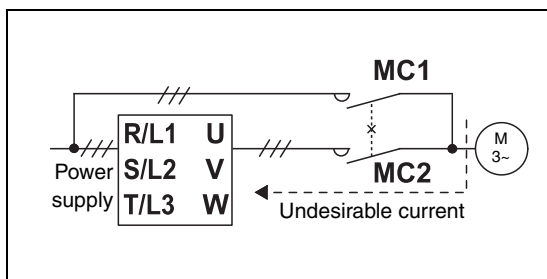

Fig. 4-1:
Mechanical interlocks for MC1 and MC2

1001042E



CAUTION:

If the machine must not be restarted when power is restored after a power failure, provide a magnetic contactor in the inverter's input side and also make up a sequence which will not switch on the start signal.

If the start signal (start switch) remains on after a power failure, the inverter will automatically restart as soon as the power is restored.

- Instructions for overload operation
When performing operation of frequent start/stop of the inverter, increase/decrease in the temperature of the transistor element of the inverter may repeat due to a continuous flow of large current, shortening the life from thermal fatigue. Since thermal fatigue is related to the amount of current, the life can be increased by reducing bound current, starting current, etc. Decreasing current may increase the life. However, decreasing current will result in insufficient torque and the inverter may not start. Therefore, increase the inverter capacity to have enough allowance for current.
- Make sure that the specifications and rating match the system requirements.
- When the motor speed is unstable, due to change in the frequency setting signal caused by electromagnetic noises from the inverter, take the following measures when applying the motor speed by the analog signal.
 - Do not run the signal cables and power cables (inverter I/O cables) in parallel with each other and do not bundle them.
 - Run signal cables as far away as possible from power cables (inverter I/O cables).
 - Use shield cables as signal cables.
 - Install a ferrite core on the signal cable (Example: ZCAT3035-1330 TDK).

4.1.1 Failsafe of the system which uses the inverter

When a fault occurs, the inverter trips to output a fault signal. However, a fault output signal may not be output at an inverter fault occurrence when the detection circuit or output circuit fails, etc. Although Mitsubishi assures best quality products, provide an interlock which uses inverter status output signals to prevent accidents such as damage to machine when the inverter fails for some reason and at the same time consider the system configuration where failsafe from outside the inverter, without using the inverter, is enabled even if the inverter fails.

Interlock method which uses the inverter status output signals

By combining the inverter status output signals to provide an interlock as shown below, an inverter alarm can be detected.

| Interlock Method | Check Method | Used Signals | Refer to Page |
|--|--|---|----------------|
| Inverter protective function operation | Operation check of an alarm contact Circuit error detection by negative logic | Fault output signal (ALM signal) | 6-128 |
| Inverter running status | Operation ready check signal | Operation ready signal (RY signal) | 6-127 |
| | Logic check of the start signal and running signal | Start signal (STF signal, STR signal) Running signal (RUN signal) | 6-103 6-127 |
| | Logic check of the start signal and output current | Start signal (STF signal, STR signal) Output current detection signal (Y12 signal) | 6-103 6-131 |

Tab. 4-1: Different output signals of the frequency inverter can be used for interlocks

Check by the output of the inverter fault signal

When the fault occurs and trips the inverter, the fault output signal (ALM signal) is output (ALM signal is assigned to terminal ABC in the initial setting). Check that the inverter functions properly. In addition, negative logic can be set (on when the inverter is normal, off when the fault occurs).

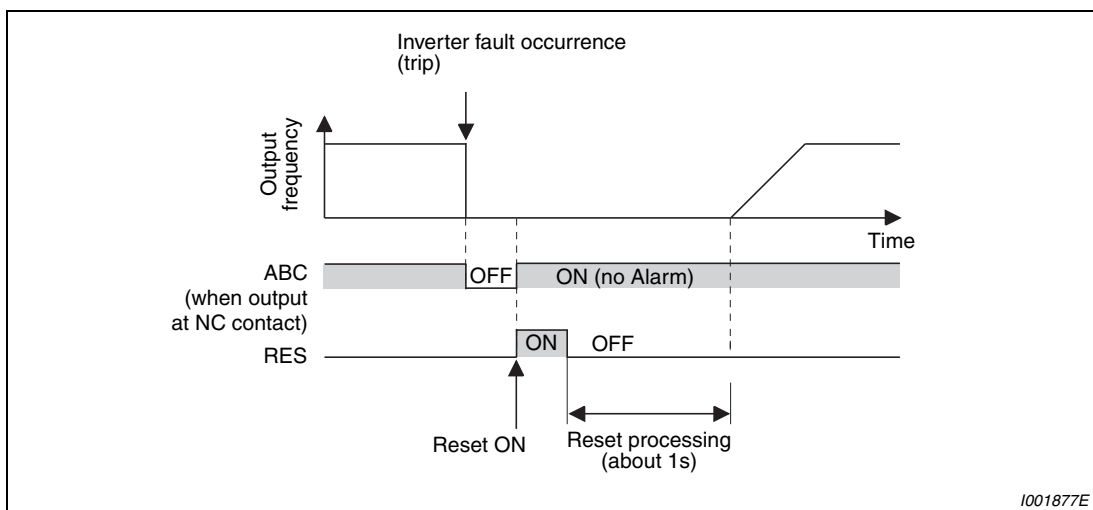

Fig. 4-2: Kontakt B-C opens when a fault occurs (initial setting)

Checking the inverter operating status by the inverter operation ready completion signal

Operation ready signal (RY signal) is output when the inverter power is on and the inverter becomes operative. Check if the RY signal is output after powering on the inverter.

Checking the inverter operating status by the start signal input to the inverter and inverter running signal

The inverter running signal (RUN signal) is output when the inverter is running (RUN signal is assigned to terminal RUN in the initial setting).

Check if RUN signal is output when inputting the start signal to the inverter (forward signal is STF signal and reverse signal is STR signal). For logic check, note that RUN signal is output for the period from the inverter decelerates until output to the motor is stopped, configure a sequence considering the inverter deceleration time.

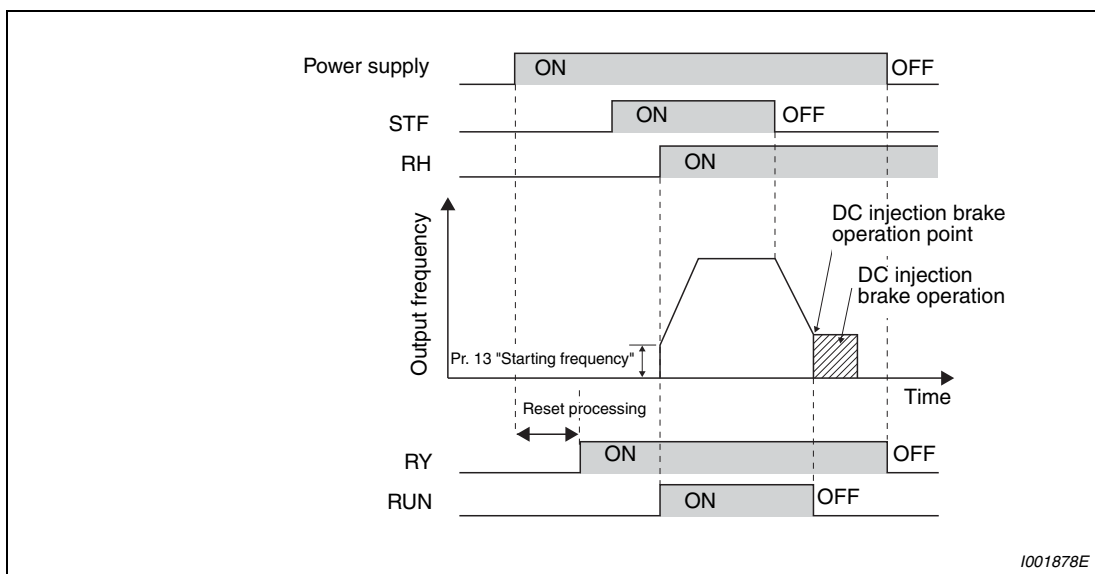

Fig. 4-3: Ready status and motor running

Checking the motor operating status by the start signal input to the inverter and inverter output current detection signal

The output current detection signal (Y12 signal) is output when the inverter operates and currents flows in the motor. Check if Y12 signal is output when inputting the start signal to the inverter (forward signal is STF signal and reverse signal is STR signal).

Note that the current level at which Y12 signal is output is set to 150% of the inverter rated current in the initial setting, it is necessary to adjust the level to around 20% using no load current of the motor as reference with Pr. 150 "Output current detection level".

For logic check, as same as the inverter running signal (RUN signal), the inverter outputs for the period from the inverter decelerates until output to the motor is stopped, configure a sequence considering the inverter deceleration time.

Output terminal function assignment

When using various signals, assign functions to Pr. 190 to Pr. 192 (output terminal function selection) referring to the table below.

| Output Signal | 190 to 192 Setting | |
|---------------|--------------------|----------------|
| | Positive Logic | Negative Logic |
| ALM | 99 | 199 |
| RY | 11 | 111 |
| RUN | 0 | 100 |
| Y12 | 12 | 112 |

Tab. 4-2: Setting in positive and negative logic

NOTE

Changing the terminal assignment using Pr. 190 to Pr. 192 "Output terminal function selection" may affect the other functions. Make setting after confirming the function of each terminal.

Backup method outside the inverter

Even if the interlock is provided by the inverter status signal, enough failsafe is not ensured depending on the failure status of the inverter itself. For example, even if the interlock is provided using the inverter fault output signal, start signal and RUN signal output, there is a case where a fault output signal is not output and RUN signal is kept output even if an inverter fault occurs. Provide a speed detector to detect the motor speed and current detector to detect the motor current and consider the backup system such as checking up as below according to the level of importance of the system.

- Start signal and actual operation check
Check the motor running and motor current while the start signal is input to the inverter by comparing the start signal to the inverter and detected speed of the speed detector or detected current of the current detector. Note that the motor current runs as the motor is running for the period until the motor stops since the inverter starts decelerating even if the start signal turns off. For the logic check, configure a sequence considering the inverter deceleration time. In addition, it is recommended to check the three-phase current when using the current detector.
- Command speed and actual operation check
Check if there is no gap between the actual speed and commanded speed by comparing the inverter speed command and detected speed of the speed detector.

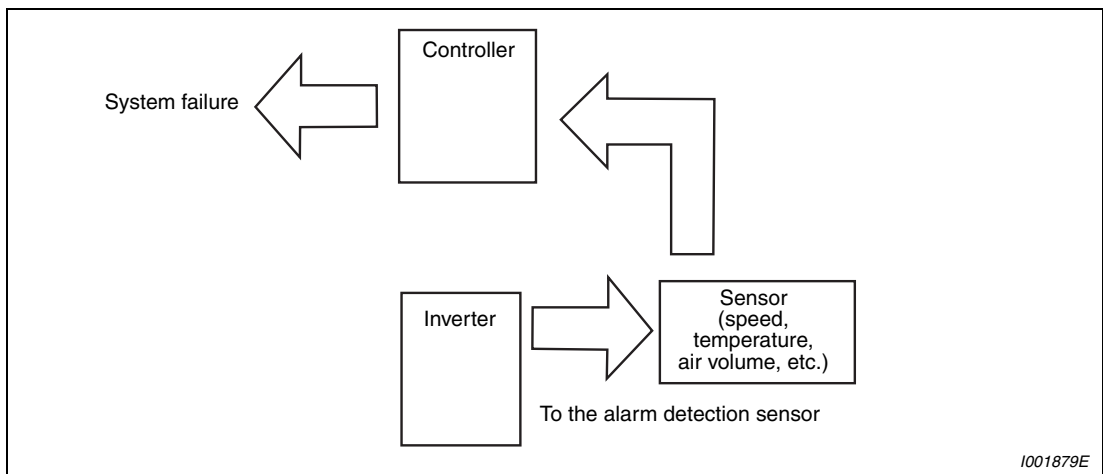

Fig. 4-4: Backup method outside the inverter

4.2 Drive the motor

The inverter needs frequency command and start command. Refer to the flow chart below to perform setting.

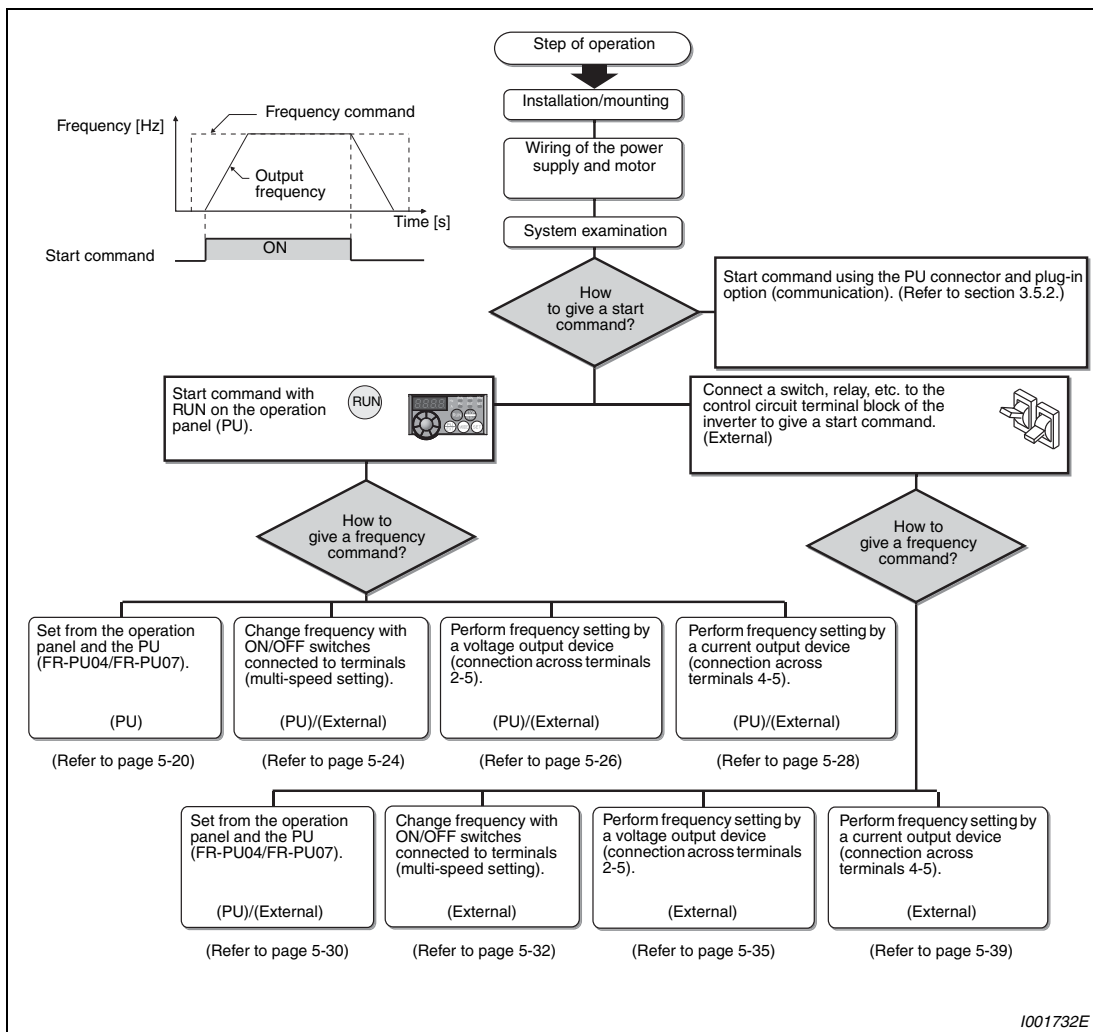

Fig. 4-5: Steps of operation

Check the following items before powering on the inverter:

- Check that the inverter is installed correctly in a correct place. (Refer to section 2.3.)
- Check that wiring is correct. (Refer to section 3.2.)
- Check that no load is connected to the motor.

NOTES

When protecting the motor from overheat by the inverter, set Pr. 9 "Electronic thermal O/L relay". (Refer to section 5.1.1.)

When the rated frequency of the motor is 60Hz, set Pr. 3 "Base frequency" (Refer to section 5.1.2.)

4.3 Operation panel

4.3.1 Parts of the operation panel

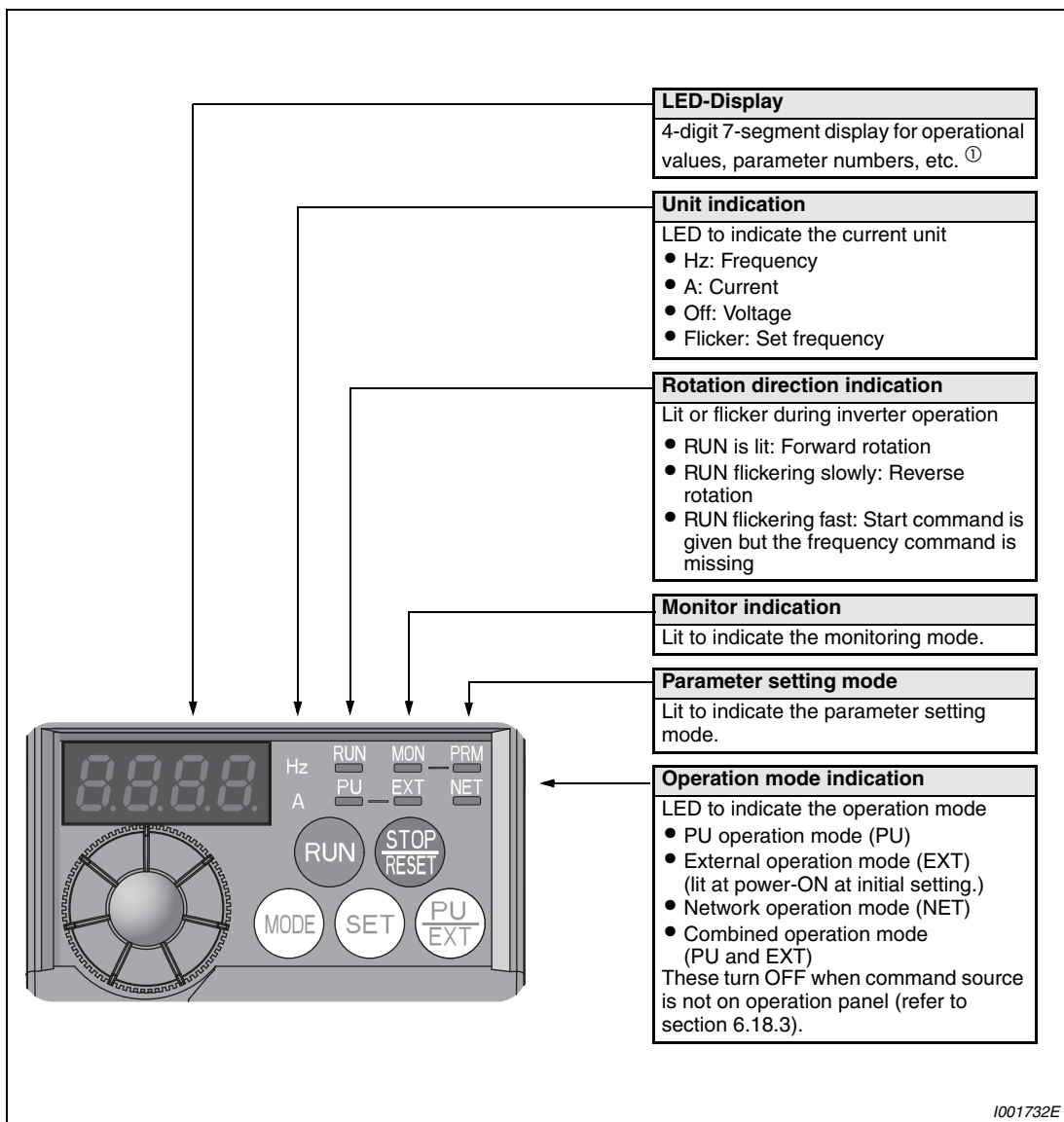
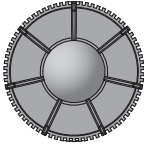



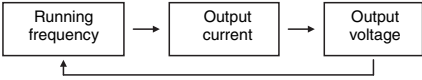



Fig. 4-6: Operation panel of the FR-E700

- ① The number of digits displayed on the operation panel is four. Only the upper four digits of values can be displayed and set. If the values to be displayed have five digits or more including decimal places, the fifth or later numerals can not be displayed nor set. When 50Hz is set, 50.00 is displayed. When 120Hz is set, 120.0 is displayed and second decimal place is not displayed nor set.

| Key | Function | Description |
|--|--------------------------------|--|
|  | Digital dial | Used to change the frequency setting and parameter values. Press to display the following. <ul style="list-style-type: none"> • Displays the set frequency in the monitor mode • Currently set value is displayed during calibration • Displays the order in the faults history mode |
|  | Rotation direction | RUN command for forward/reverse rotation. The rotation direction can be selected by setting Pr. 40. |
|  | Stop operation/ Fault reset | <ul style="list-style-type: none"> • Used to stop RUN command. • Fault can be reset when protective function is activated (fault). |
|  | Mode switch over | Used to change each setting mode. <ul style="list-style-type: none"> • Pressing PU/EXT simultaneously changes the operation mode (refer to section 4.3.3). • Pressing for a while (2s) can lock operation (refer to section 4.3.4). |
|  | Write settings | If pressed during operation, monitor changes as below: <div style="text-align: center; margin-top: 10px;">  <pre> graph LR A[Running frequency] --> B[Output current] B --> C[Output voltage] C --> A </pre> </div> |
|  | Operation mode switch over | Used to switch between the PU and external operation mode. When using the external operation mode (operation using a separately connected frequency setting potentiometer and start signal), press this key to light up the EXT indication. (Press MODE simultaneously (0.5s) or change Pr. 79 setting to change to combined mode.) PU: PU operation mode EXT: External operation mode (Cancels PU stop also.) |

Tab. 4-3: Keys of the operation panel

4.3.2 Basic operation (factory setting)

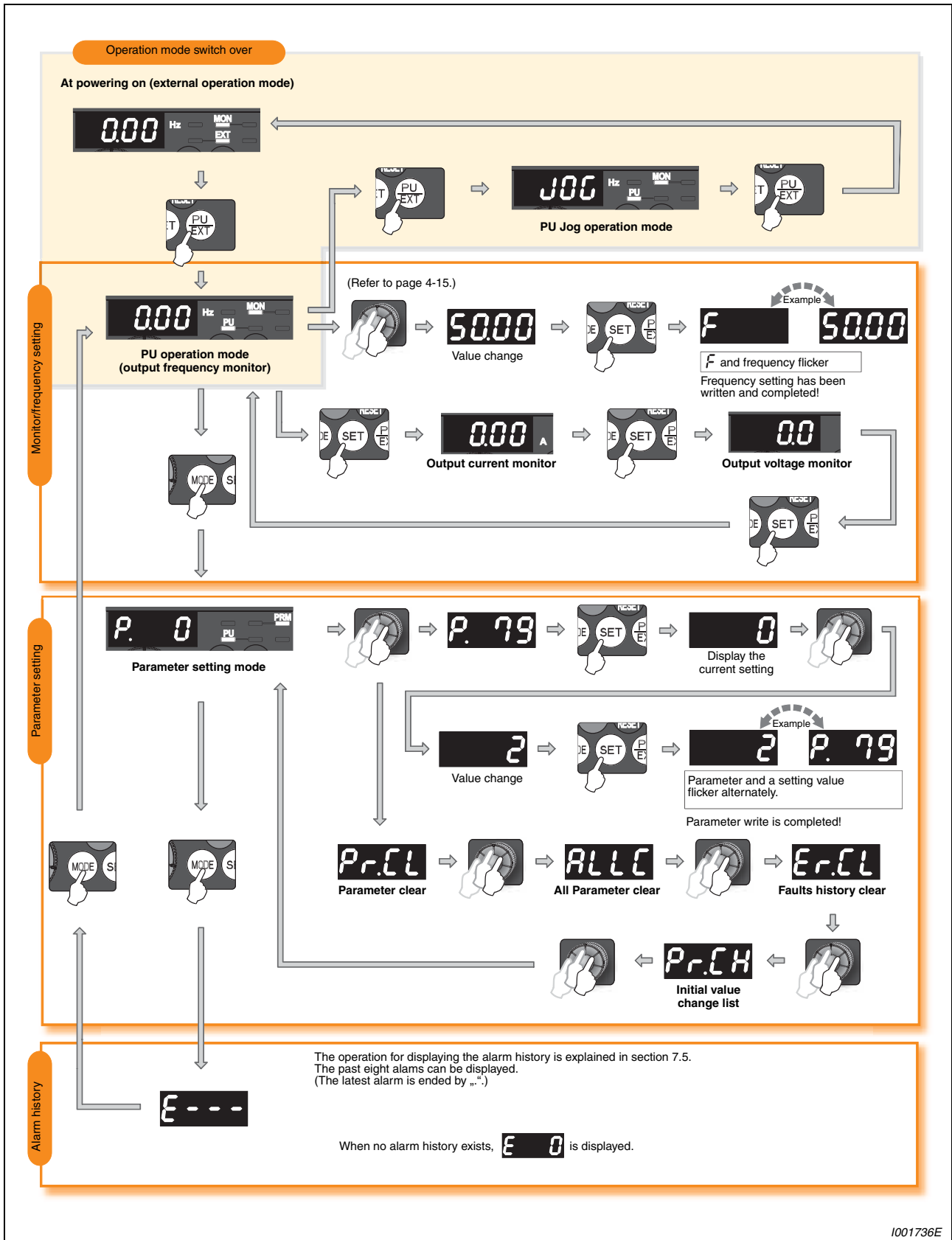

Fig. 4-7: Overview of the basic functions of the operation panel

4.3.3 Easy operation mode setting (easy setting mode)

A frequency inverter can be controlled alone via the control unit, through external signals (switch, SPC outputs, external setpoint sources, etc.) or through a combination of external signals and inputs to the control unit. The choice of operation mode is done by setting parameter 79. (Refer to section 5.1.6.)

Setting of Pr. 79 "Operation mode selection" according to combination of the start command and speed command can be easily made.

In the following example the parameter is set to the value "3" so that the motor is started by signals to the STF and STR terminals and the speed can be adjusted using the digital dial on the operator device.

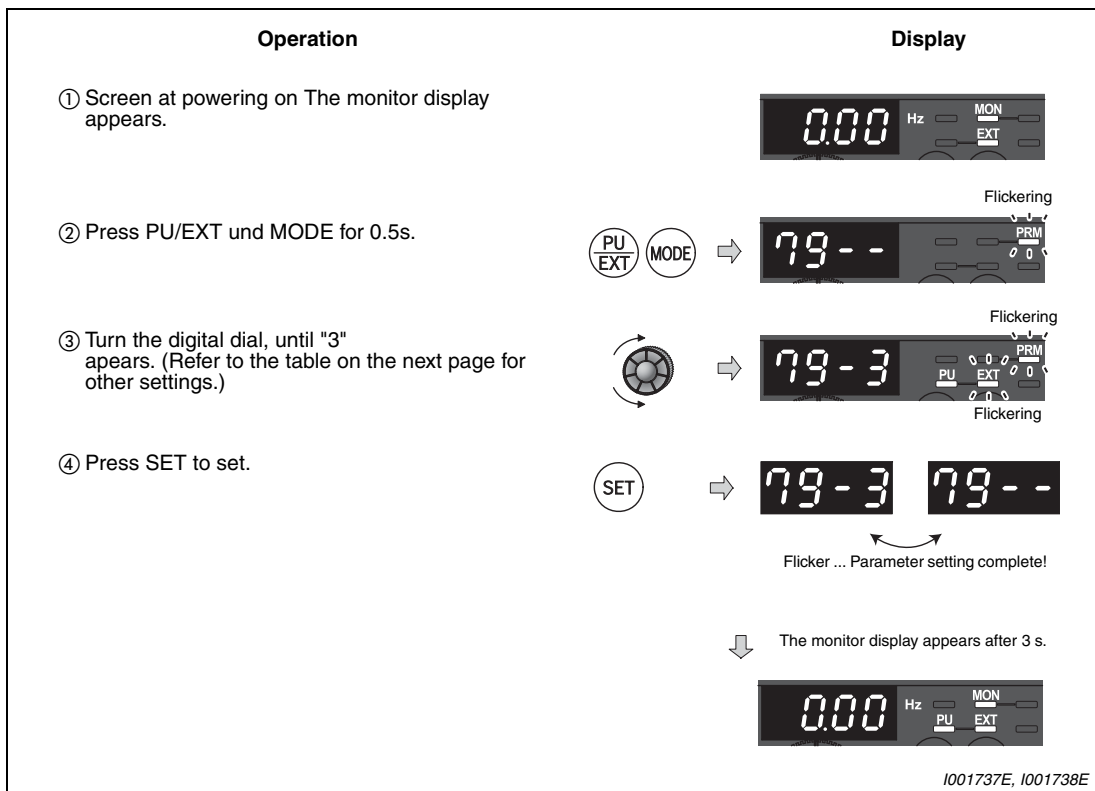
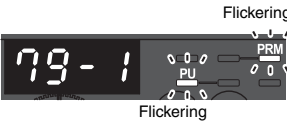



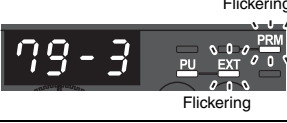

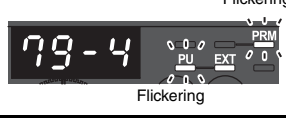



Fig. 4-8: One can immediately change parameter 79 by simultaneously pressing the PU/EXT and MODE buttons.

NOTES

Press MODE before pressing SET to return to the monitor display without setting. In this case, the mode changes to external operation mode when performed in the PU operation mode (PU JOG operation mode) and PU operation mode when performed in the external operation mode.

Reset can be made with STOP/RESET.

| Operation Panel Indication | Operation Panel Indication | Operation Method | |
|----------------------------|---|---|---|
| | | Start command | Frequency command |
| PU Modes |  |  |  |
| External operation mode |  | External (STF-, STR) | External (Analog signal at terminal 2 (voltage) or 4 (current)) |
| Combined operation mode 1 |  | External (STF-, STR) |  |
| Combined operation mode 2 |  |  | External (Analog signal at terminal 2 (voltage) or 4 (current)) |

Tab. 4-4: Operation modes and operation panel indication

Possible faults:

- "Er1" is displayed ... Why?
 - Pr. 79 is not registered in user group with "1" in Pr. 160 "User group read selection".
 - Parameter write is disabled with "1" set in Pr. 77.
- "Er2" is displayed ... Why?
 - Setting can not be made during operation. Turn the start switch (RUN, STF or STR) off.
- The priorities of the frequency commands when Pr. 79 = "3" are "Multi-speed operation (RL/RM/RH/REX) > PID control (X14) > terminal 4 analog input (AU) > digital input from the operation panel".

4.3.4 Operation lock

Operation using the digital dial and key of the operation panel can be made invalid to prevent parameter change and unexpected start and stop.

Operation lock

- Set "10" or "11" in Pr. 161, then press the MODE key for 2s to make the digital dial key operation invalid.
- When the digital dial and key operation is made invalid, "HOLD" appears on the operation panel.
- When the digital dial and key operation is invalid, "HOLD" appears if the digital dial or key operation is performed. (When the digital dial or key operation is not performed for 2s, the monitor display appears.)

Operation unlock

To make the digital dial and key operation valid again, press the MODE key for 2s.

NOTES

| The STOP/RESET key is valid even in the operation lock status.

| Set "0" (extended mode parameter valid) in Pr. 160 "User group read selection".

| Set "10" or "11" (key lock mode valid) in Pr. 161 "Frequency setting/key lock operation selection".

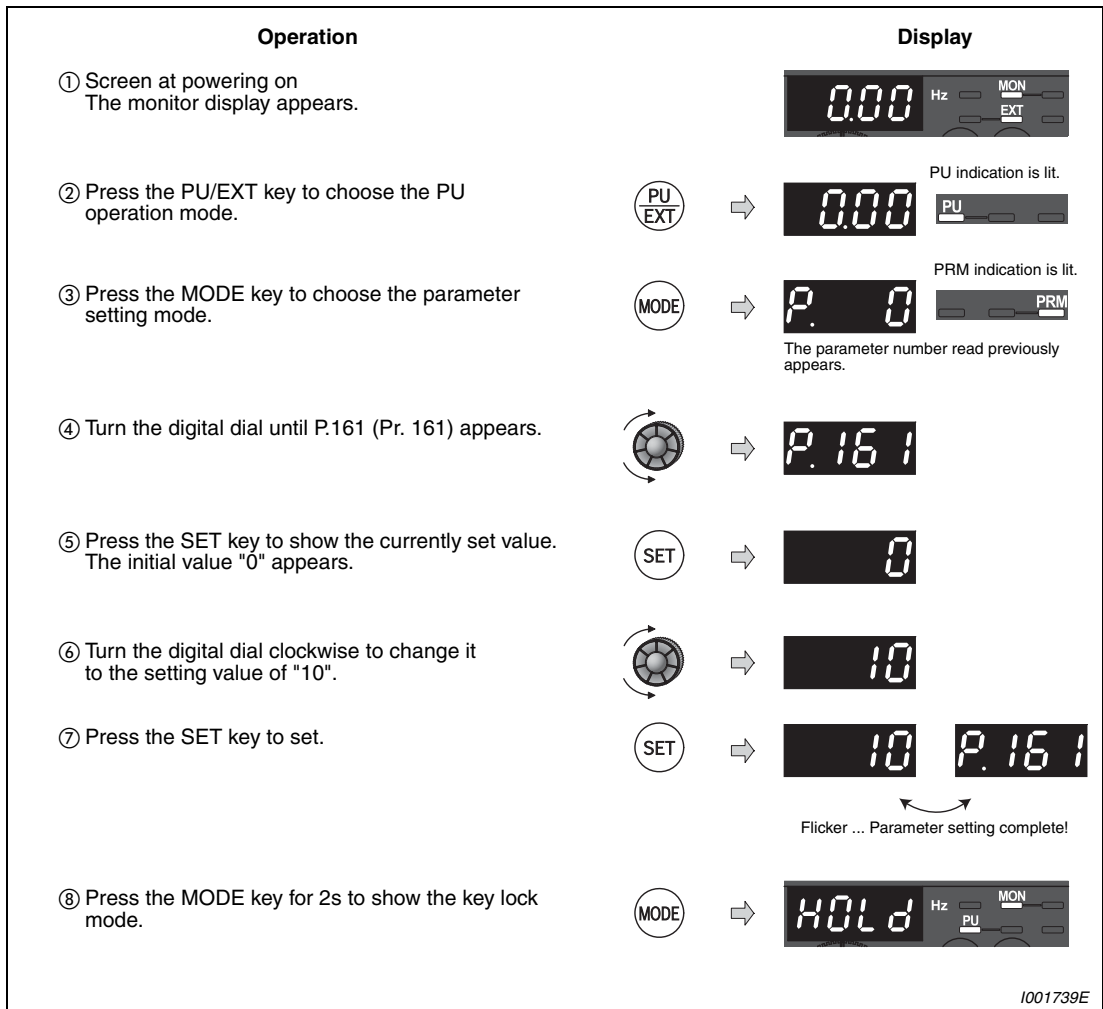

I001739E

Fig. 4-9: Operation lock

4.3.5 Monitoring of output current and output voltage

Monitor display of output frequency, output current and output voltage can be changed by pushing the SET key during monitoring mode.

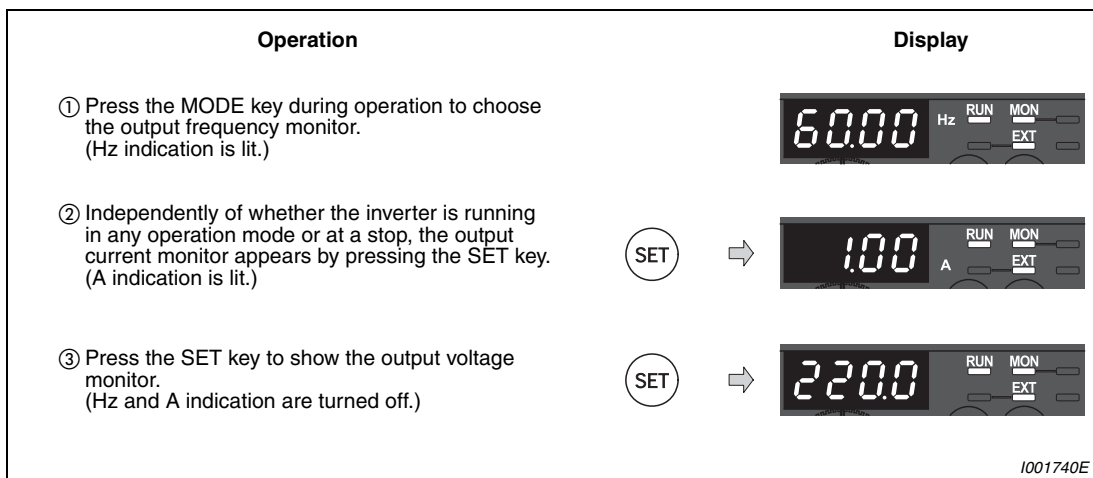

Fig. 4-10: Monitoring of output current and output voltage

4.3.6 First priority monitor

Hold down the SET key for 1s to set monitor description to be appeared first in the monitor mode.
(To return to the output frequency monitor, hold down the SET key for 1s after displaying the output frequency monitor.)

4.3.7 Digital dial push

Appears when PU operation mode or external/PU combined operation mode 1 is selected (Pr. 79 = "3").

Push the digital dial to display the set frequency currently set.

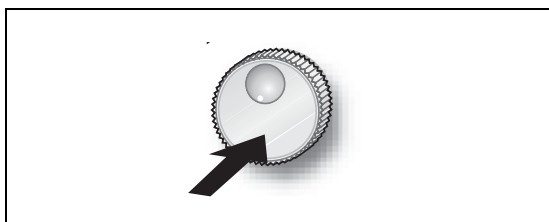

Fig. 4-11:
Display the set frequency currently set

I001067E

4.3.8 Change the parameter setting value

Example ▾ Change the Pr. 1 "Maximum frequency" setting from 120Hz to 50Hz.

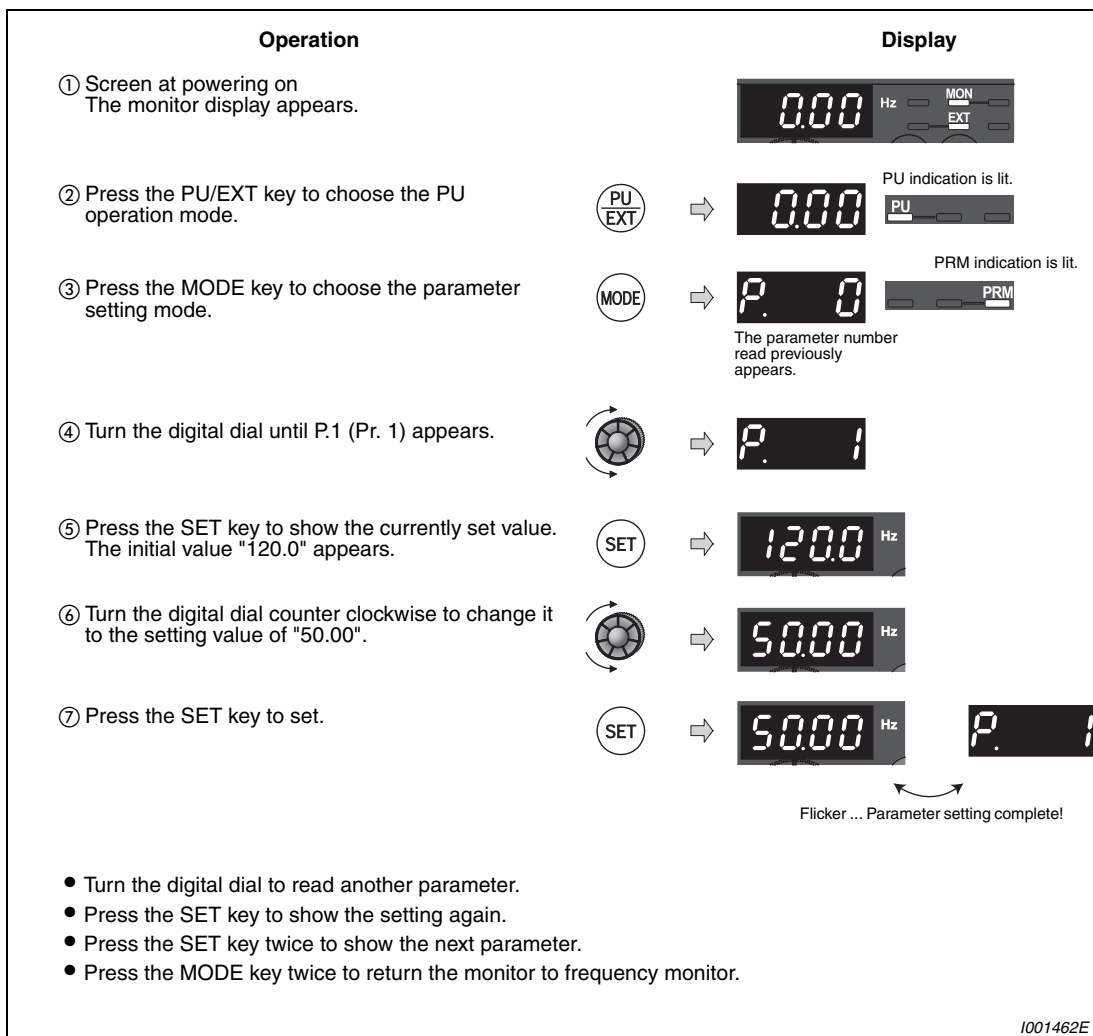

Fig. 4-12: Setting the maximum output frequency

Possible faults:

- "Er1" to "Er4" is displayed ... Why?
 - The error indication means:
 - Er1: Write disable error
 - Er2: Write error during operation
 - Er3: Calibration error
 - Er4: Mode designation error

For details refer to section 7.1.

4.3.9 Parameter clear/All Parameter clear

- Set "1" in Pr.CL "Parameter clear" or ALLC "all parameter clear" to initialize all parameters. (Parameters are not cleared when "1" is set in Pr. 77 "Parameter write selection".)
- Parameter clear returns all parameters except calibration parameters C1 (Pr. 901) to C7 (Pr. 905) and the terminal function selection parameters to the initial values.
- Refer to the extended parameter list Tab. 6-1 for parameters cleared with this operation.

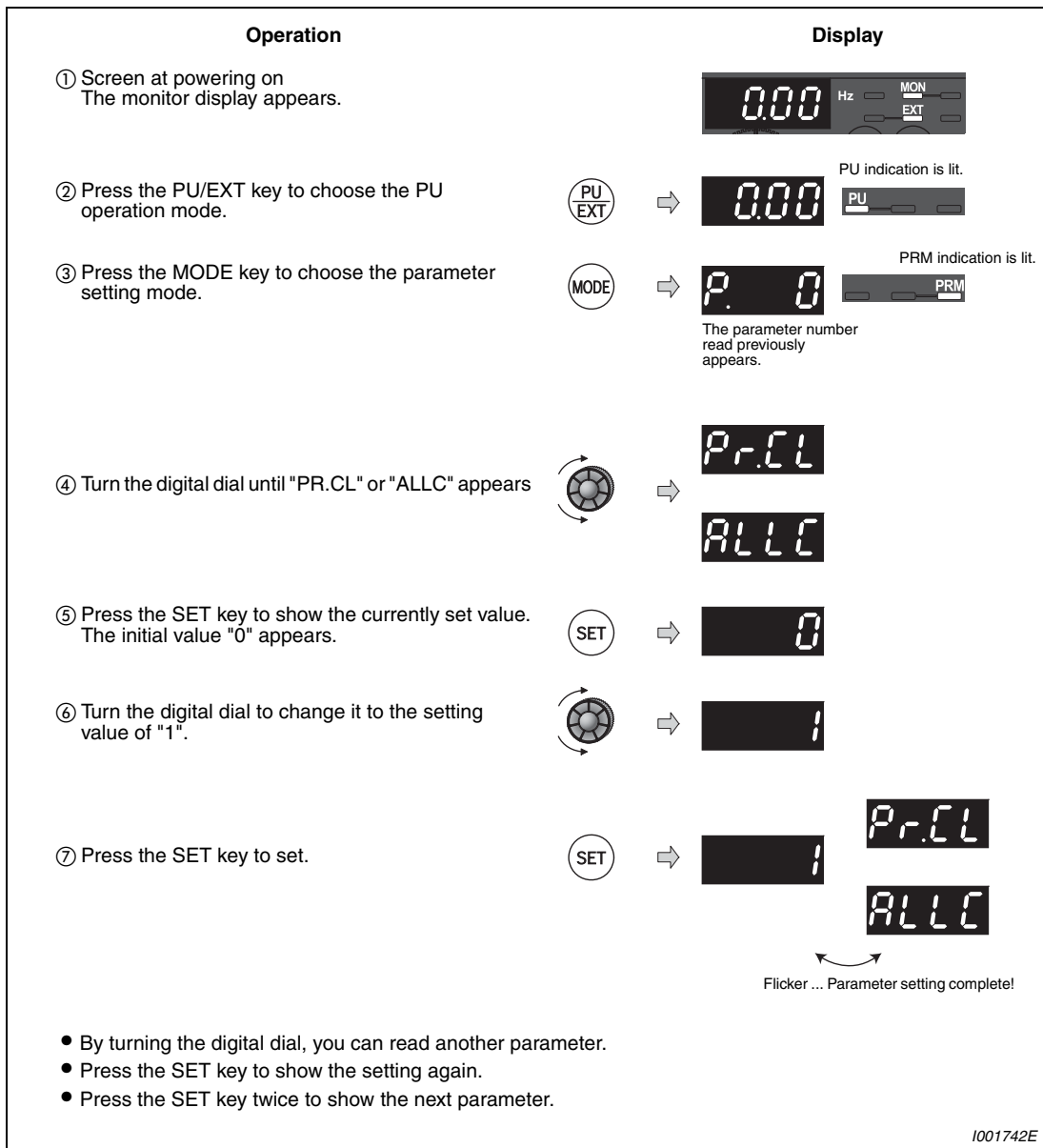

Fig. 4-13: Parameter clear

Possible faults:

- "1" and "Er4" are displayed alternately.
 - The inverter is not in the PU operation mode. Press the PU/EXT key. The PU indication is lit and the monitor (4 digit LED) displays "1". (When Pr. 79 = "0" (initial value)). Carry out operation from step ⑥ again.

4.3.10 Initial value change list

Displays and sets the parameters changed from the initial value.

NOTES

Calibration parameters (C1 (Pr. 901) to C7 (Pr. 905)) are not displayed even they are changed from the initial settings.

Only simple mode parameter is displayed when simple mode is set (Pr. 160 = 9999).

Only user group is displayed when user group is set (Pr. 160 = "1").

Pr. 160 is displayed independently of whether the setting value is changed or not.

When parameter setting is changed after creating the initial value change list, the setting will be reflected to the initial value change list next time.

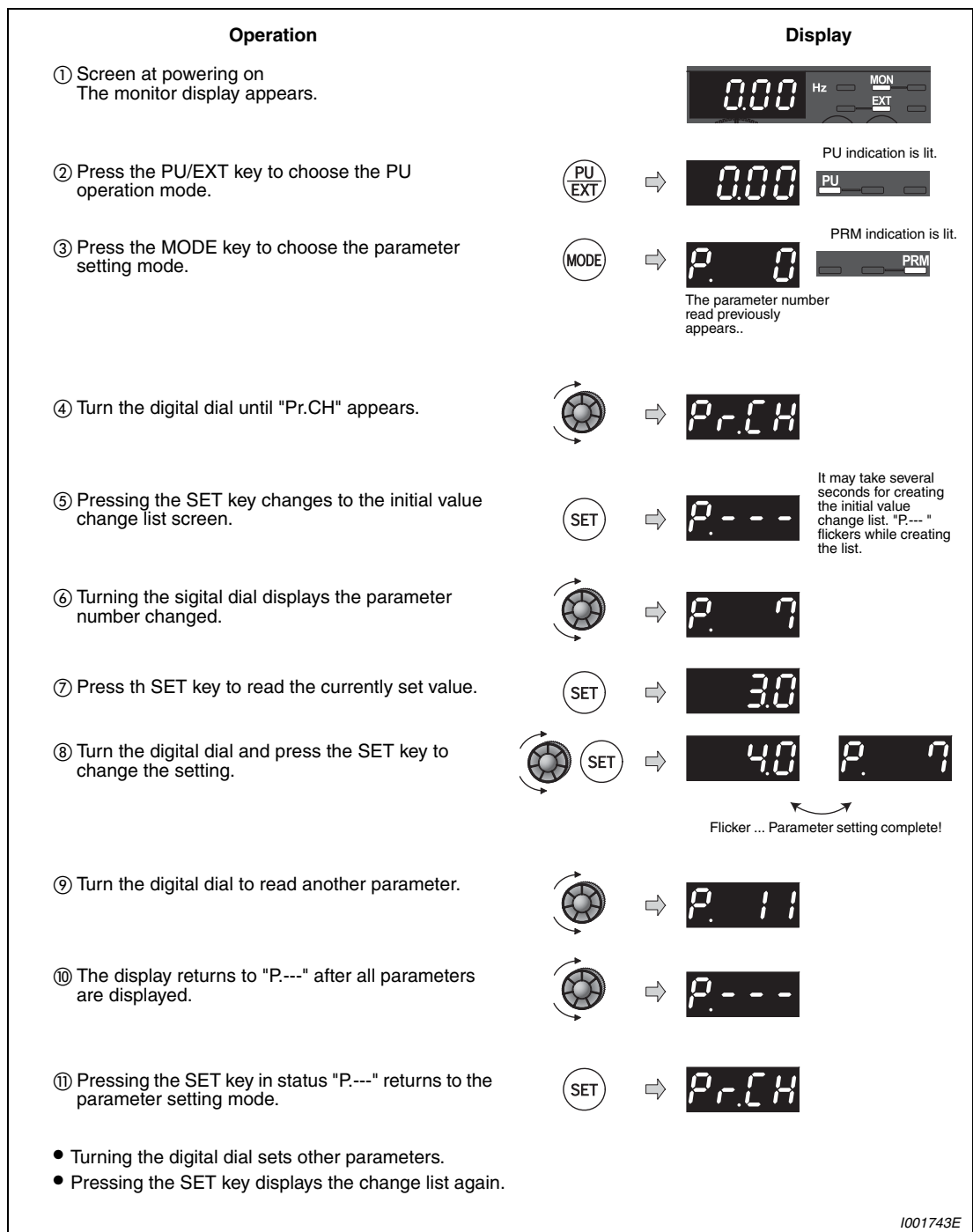

Fig. 4-14: Initial value change list

5 Basic settings

5.1 Simple mode parameter list

For simple variable-speed operation of the inverter, the initial setting of the parameters may be used as they are. Set the necessary parameters to meet the load and operational specifications. Parameter setting, change and check can be made from the operation panel. For details of parameters, refer to chapter 6.

NOTE

Only simple mode parameter can be displayed using Pr. 160 "User group read selection". All parameters are displayed with the initial setting. Set Pr. 160 "User group read selection" as required. (Refer to section 6.17.4)

| Pr. 160 | Description |
|-------------------|--|
| 9999 | Only the simple mode parameters can be displayed. |
| 0 (Initial value) | Simple mode and extended mode parameters can be displayed. |
| 1 | Only parameters registered in the user group can be displayed. |

Tab. 5-1: Setting of parameter 160

| Pr. | Name | Increments | Initial Value | Range | Description | Refer to | |
|-----|----------------------------------|------------|-------------------------------|---------------|---|--|------|
| 0 | Torque boost | 0.1% | 6/4/3/2% ^① | 0–30% | Set to increase a starting torque or when the motor with a load will not rotate, resulting in an alarm (OL) and a trip (OC1). | 5-5 | |
| 1 | Maximum frequency | 0.01Hz | 120Hz | 0–120Hz | Set when the maximum output frequency need to be limited. | 5-7 | |
| 2 | Minimum frequency | 0.01Hz | 0Hz | | Set when the minimum output frequency need to be limited. | | |
| 3 | Base frequency | 0.01Hz | 50Hz | 0–400Hz | Check the motor rating plate. | 5-4 | |
| 4 | Multi-speed setting | RH | 50Hz | 0–400Hz | Set when changing the preset speed in the parameter with a terminal. | 5-32 | |
| 5 | | RM | 30Hz | | | | |
| 6 | | RL | 10Hz | | | | |
| 7 | Acceleration time | 0.1s | 5/10/15s ^② | 0–3600s | Acceleration/deceleration time can be set. | 5-9 | |
| 8 | Deceleration time | | 5/10/15s ^② | | | | |
| 9 | Electronic thermal O/L relay | 0.01A | Rated inverter output current | 0–500A | Protect the motor from overheat by the inverter. Set the rated motor current. | 5-2 | |
| 79 | Operation mode selection | 1 | 0 | 0/1/2/3/4/6/7 | Select the start command location and frequency command location. | 5-11 | |
| 125 | Frequency setting gain frequency | Terminal 2 | 0.01Hz | 50Hz | 0–400Hz | Frequency for the maximum value of the potentiometer (at 5V) can be changed. | 5-38 |
| 126 | | Terminal 4 | | | | Frequency at 20mA input can be changed. | 5-41 |
| 160 | User group read selection | 1 | 0 | 0/1/9999 | Make extended parameters valid | 6-195 | |

Tab. 5-2: Simple mode parameters

- ① Initial values differ according to the inverter capacity:
 6 %: FR-E720S-050 or less, FR-E740-026 or less
 4 %: FR-E720S-080 and 110, FR-E740-040 to 095
 3 %: FR-E740-120 and 170
 2 %: FR-E740-230 and 300
- ② Initial values differ according to the inverter capacity:
 5 s: FR-E720S-110 or less, FR-E740-095 or less
 10 s: FR-E740-120 and 170
 15 s: FR-E740-230 and 300

5.1.1 Overheat protection of the motor by the inverter

Set this parameter when using a motor other than the Mitsubishi standard motor (SF-JR) and Mitsubishi constant torque motor (SF-HRCA). Set the rated motor current in Pr. 9 "Electronic thermal O/L relay" to protect the motor from overheat.

| Pr. No. | Name | Initial Value | Setting Range | Description |
|---------|------------------------------|--|---------------|------------------------------|
| 9 | Electronic thermal O/L relay | Rated inverter output current ^① | 0-500A | Set the rated motor current. |

① The initial value of the FR-E740-026 or less, FR-E720S-050 or less is set to 85% of the rated inverter current.

② Refer to appendix A for the rated inverter current value.

Example ▾

Change the Pr. 9 "Electronic thermal O/L relay" setting to 5A according to the motor rated current.

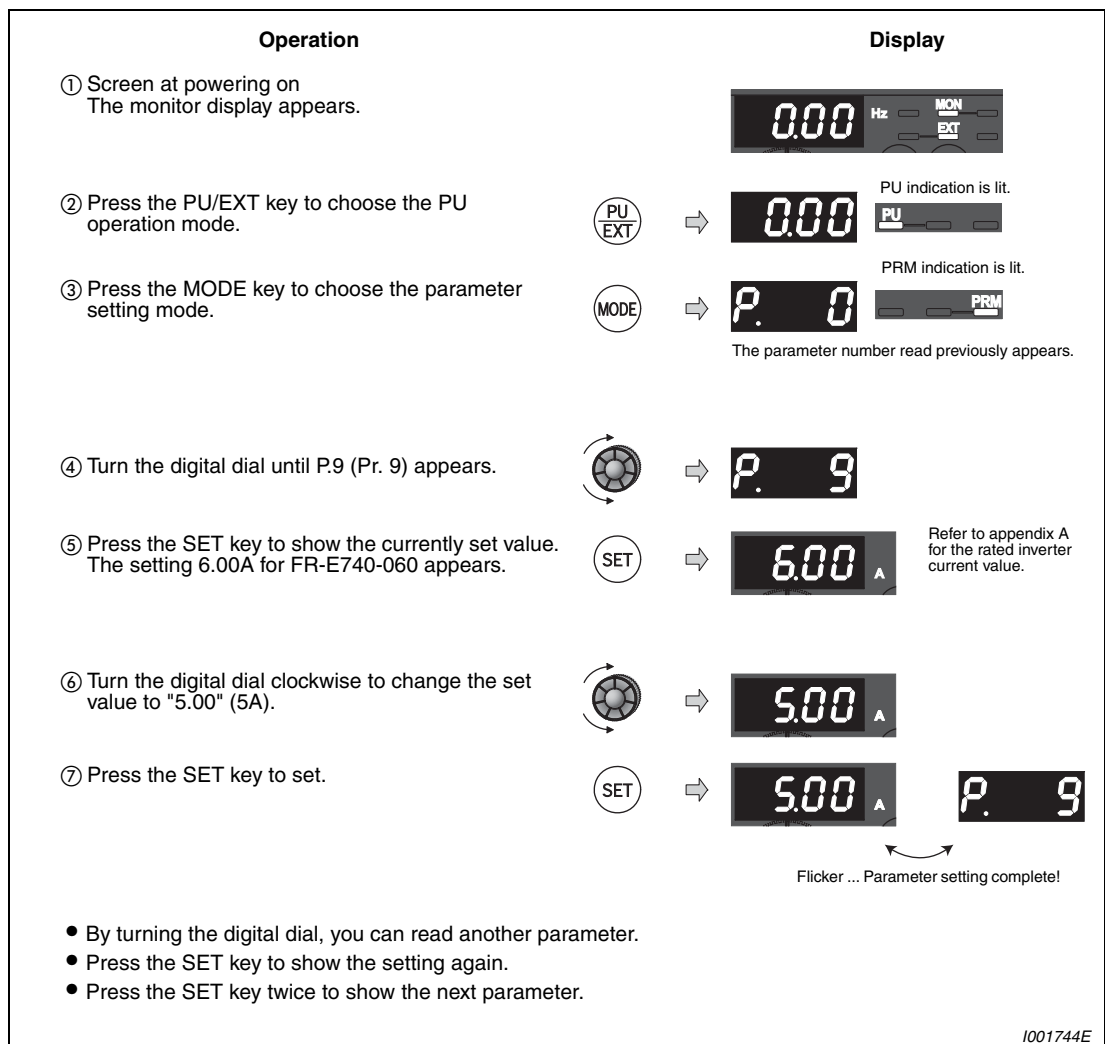

Fig. 5-1: Setting of the electronic thermal O/L relay



NOTES

Protective function by electronic thermal relay function is reset by inverter power reset and reset signal input. Avoid unnecessary reset and power-off.

When two or more motors are connected to the inverter, they cannot be protected by the electronic thermal relay function. Install an external thermal relay to each motor.

When the difference between the inverter and motor capacities is large and the setting is small, the protective characteristics of the electronic over current protection will be deteriorated. In this case, use an external thermal relay.

A special motor cannot be protected by the electronic thermal relay function. Use an external thermal relay.

Electronic thermal relay does not work when 5% or less of inverter rated current is set to electronic thermal relay setting.

5.1.2 When the rated motor frequency is 60Hz (Pr. 3)

First, check the motor rating plate. If a frequency given on the rating plate is "60Hz" only, always set Pr. 3 "Base frequency" to "60Hz". Leaving the base frequency unchanged from "50Hz" may make the voltage low and the torque insufficient. It may result in an inverter trip due to overload.

| Pr. No. | Name | Initial Value | Setting Range | Description |
|----------|----------------|---------------|---------------|--------------------------------|
| 3 | Base frequency | 50Hz | 0-400Hz | Set the rated motor frequency. |

Example ▽ Change Pr. 3 "Base frequency" to 60Hz according to the motor rated frequency.

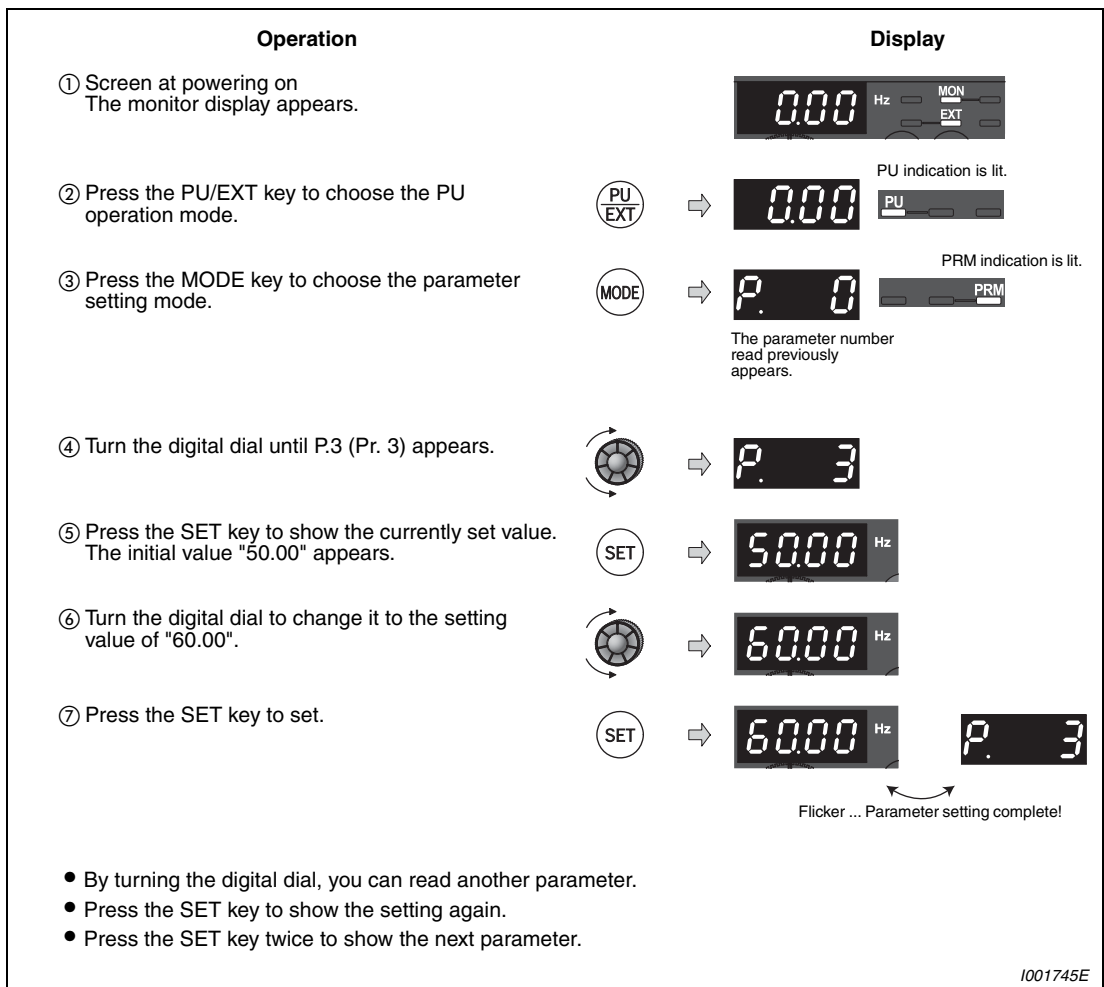

Fig. 5-2: Setting the base frequency



5.1.3 Increase the starting torque (Pr. 0)

Set this parameter when the motor with a load does not rotate, an alarm OL is output, resulting in an inverter trip due to OC1, etc.

| Pr. No. | Name | Initial Value | Setting Range | Description | |
|----------|--------------|--|---------------|-------------|--|
| 0 | Torque boost | FR-E720S-008 to 050 FR-E740-016 and 026 | 6% | 0-30% | Motor torque in the low-frequency range can be adjusted to the load to increase the starting motor torque. |
| | | FR-E720S-080 and 110 FR-E740-040 to 095 | 4% | | |
| | | FR-E740-120 and 170 | 3% | | |
| | | FR-E740-230 and 300 | 2% | | |

Example ▽

When the motor with a load does not rotate, increase the Pr. 0 value 1% by 1% unit by looking at the motor movement. (The guideline is for about 10% change at the greatest.)

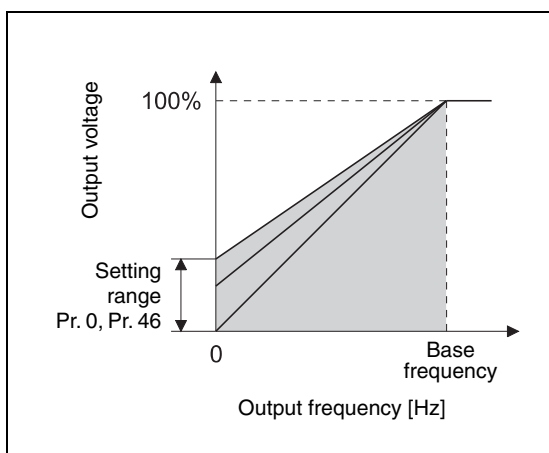

Fig. 5-3:
Relation between output frequency and output voltage

1001098E

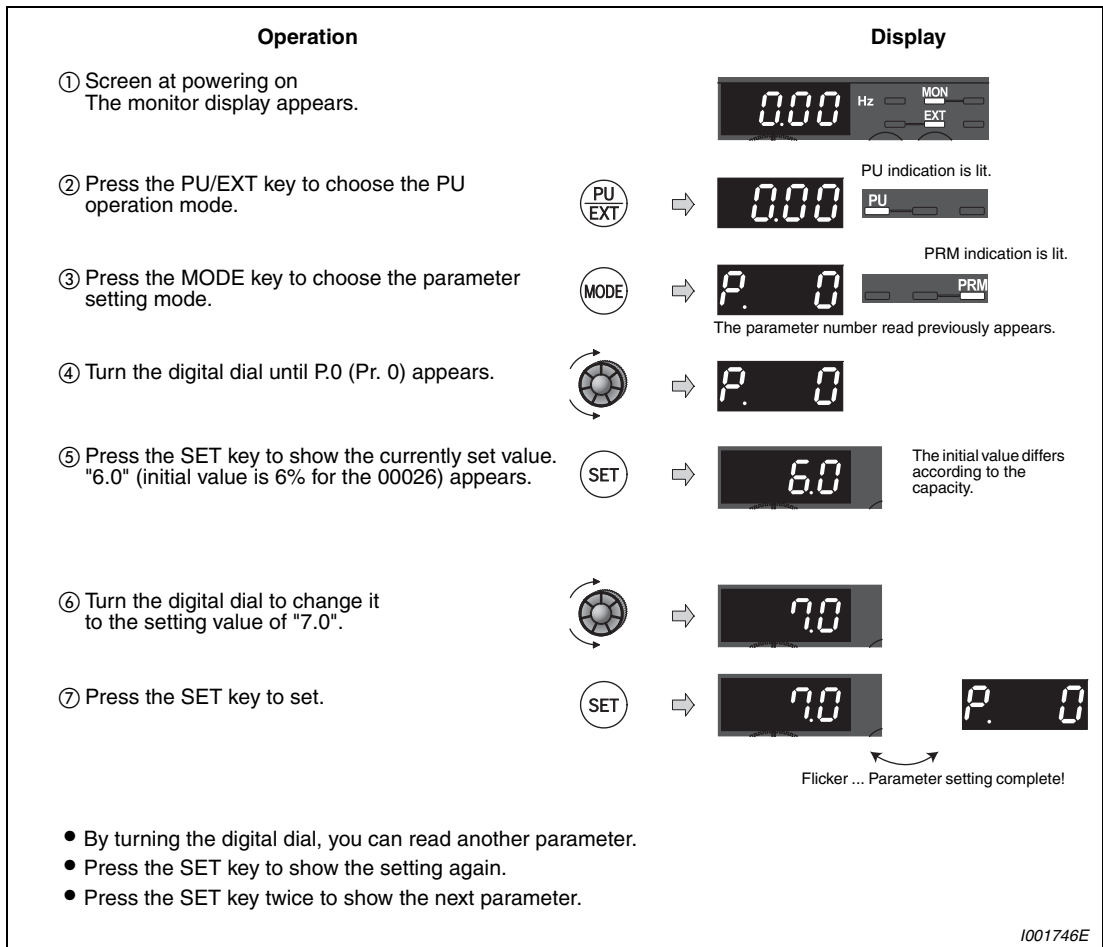

Fig. 5-4: Setting the starting torque



NOTES

A too large setting will cause the motor to overheat, resulting in an over current trip (OL (over current alarm) then E.OC1 (over current shutoff during acceleration)), thermal trip (E.THM (Motor overload shutoff), and E.THT (Inverter overload shutoff)).
When an error (E.OC1) occurs, release the start command, and decrease the value 1% by 1%. (Refer to page 7-8.)

If the inverter still does not operate properly after the above measures, adjust the acceleration/deceleration setting or activate the vector control function by Pr. 80 "Motor capacity". (Refer to section 6.3.2.)

5.1.4 Limit the maximum and minimum output frequency (Pr. 1, Pr. 2)

| Pr. No. | Name | Initial Value | Setting Range | Description |
|---------|-------------------|---------------|---------------|--|
| 1 | Maximum frequency | 120Hz | 0-120Hz | Set the upper limit of the output frequency. |
| 2 | Minimum frequency | 0Hz | 0-120Hz | Set the lower limit of the output frequency. |

Example ▾

You can limit the motor speed. Limit the frequency set by the potentiometer, etc. to 50Hz maximum. (Set "50"Hz to Pr. 1 "Maximum frequency".)

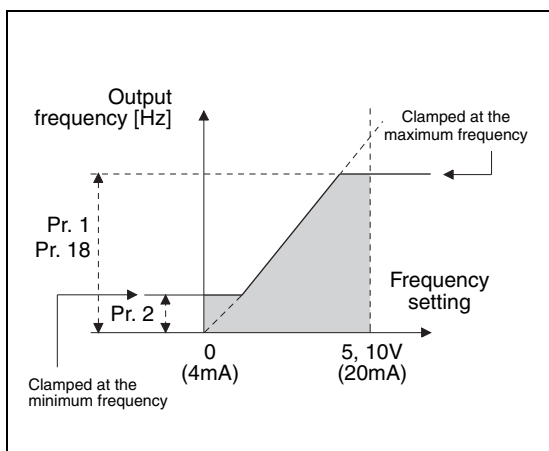

Fig. 5-5:
Minimum and maximum output frequency

I001100E

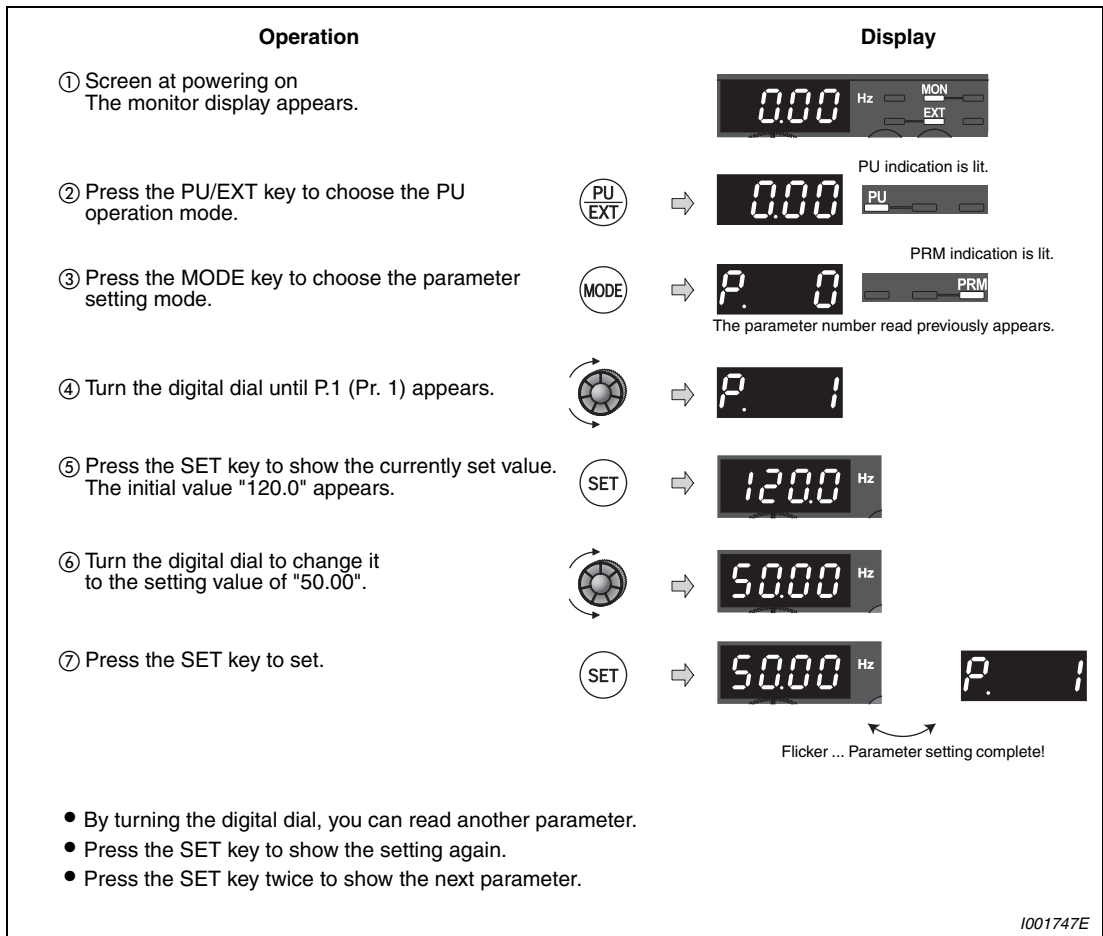

Fig. 5-6: Setting the maximum frequency



NOTES

The output frequency is clamped by the Pr. 2 setting even the set frequency is lower than the Pr. 2 setting (The frequency will not decrease to the Pr. 2 setting.) Note that Pr. 15 "Jog frequency" has higher priority than the minimum frequency.

When the Pr. 1 setting is changed, frequency higher than the Pr. 1 setting can not be set by the digital dial.

When performing a high speed operation at 120Hz or more, setting of Pr. 18 "High speed maximum frequency" is necessary. (Refer to section. 6.4.1.)



CAUTION:

If the Pr. 2 setting is higher than the Pr. 13 "Starting frequency" value, note that the motor will run at the set frequency according to the acceleration time setting by merely switching the start signal on, without entry of the command frequency.

5.1.5 Change the acceleration/deceleration time (Pr. 7, Pr. 8)

Set in Pr. 7 "Acceleration time" a larger value for a slower speed increase and a smaller value for a faster speed increase.

Set in Pr. 8 "Deceleration time" a larger value for a slower speed decrease and a smaller value for a faster speed decrease.

| Pr. No. | Name | Initial Value | | Setting Range | Description |
|---------|-------------------|---------------------------------|-----|----------------------|----------------------------------|
| 7 | Acceleration time | ≤ FR-E720S-110 ≤ FR-E740-095 | 5s | 0-3600s/ 0-360s ① | Set the motor acceleration time. |
| | | FR-E740-120 and 170 | 10s | | |
| | | FR-E740-230 and 300 | 15s | | |
| 8 | Deceleration time | ≤ FR-E720S-110 ≤ FR-E740-095 | 5s | 0-3600s/ 0-360s ① | Set the motor deceleration time. |
| | | FR-E740-120 and 170 | 10s | | |
| | | FR-E740-230 and 300 | 15s | | |

① Depends on the Pr. 21 "Acceleration/deceleration time increments" setting. The initial value for the setting range is "0 to 3600s" and setting increments is "0.1s".

NOTE

Too short acceleration/deceleration times may lead to an inverter shutoff with error message (E.THT, E.THM, E.OCT, E.OVT ...).

Example ▾

Change the Pr. 7 "Acceleration time" setting from "5s" to "10s".

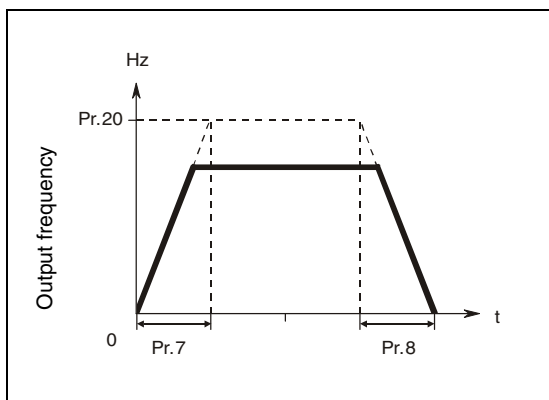

Fig. 5-7:
Acceleration/deceleration time

1000006C

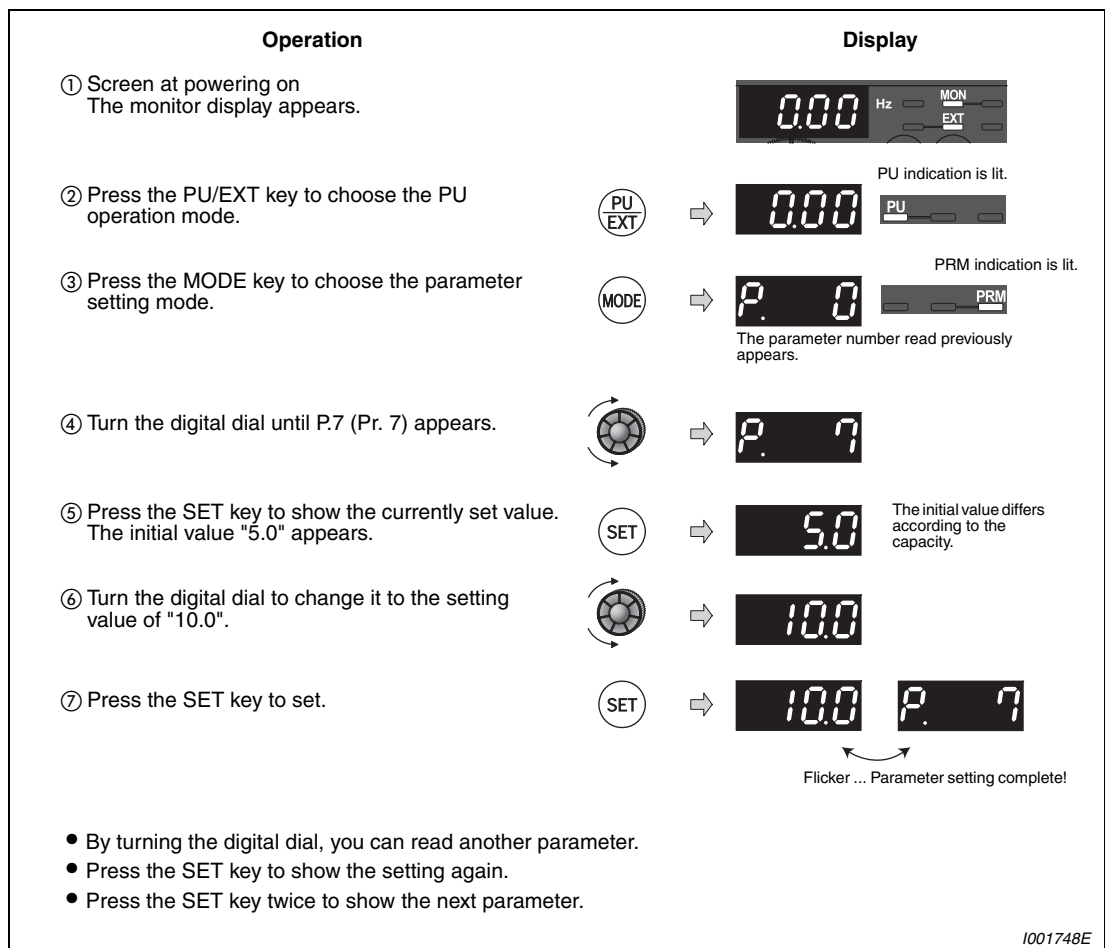















Fig. 5-8: Setting the acceleration time



5.1.6 Operation mode (Pr. 79)

Select the operation command location and frequency command location.

| Pr. No. | Name | Initial Value | Setting Range | Description | LED Indication  : OFF  : ON | | | | | |
|---|--|---|--|--|--|-------------------|---|--|--|---|
| 79 | Operation mode selection | 0 | 0 | External/PU switch over mode Press the PU/EXT key to switch between the PU and external operation mode. (Refer to section 4.3.3.) At power on, the inverter is in the external operation mode. | External operation mode  PU operation mode  | | | | | |
| | | | 1 | PU operation mode |  | | | | | |
| | | | 2 | Fixed to external operation mode Operation can be performed by switching between the external and Net operation mode. | External operation mode  NET operation mode  | | | | | |
| | | | 3 | External/PU combined operation mode 1 | <table border="1"> <tr> <th>Running frequency</th> <th>Start signal</th> </tr> <tr> <td>Operation panel and PU (FR-PU04/FR-PU07) setting or external signal input (multi-speed setting, across terminals 4-5 (valid when AU signal turns on)).</td> <td>External signal input (terminal STF-, STR)</td> </tr> </table> | Running frequency | Start signal | Operation panel and PU (FR-PU04/FR-PU07) setting or external signal input (multi-speed setting, across terminals 4-5 (valid when AU signal turns on)). | External signal input (terminal STF-, STR) |  |
| | | | | Running frequency | | Start signal | | | | |
| | | | Operation panel and PU (FR-PU04/FR-PU07) setting or external signal input (multi-speed setting, across terminals 4-5 (valid when AU signal turns on)). | External signal input (terminal STF-, STR) | | | | | | |
| | | | External/PU combined operation mode 2 | <table border="1"> <tr> <th>Running frequency</th> <th>Start signal</th> </tr> <tr> <td>External signal input (Terminal 2, 4, JOG, multi-speed selection, etc.)</td> <td>Input using the RUN-key of the operation panel or FWD/REV of the PU (FR-PU04/FR-PU07)</td> </tr> </table> | Running frequency | Start signal | External signal input (Terminal 2, 4, JOG, multi-speed selection, etc.) | Input using the RUN-key of the operation panel or FWD/REV of the PU (FR-PU04/FR-PU07) | | |
| Running frequency | Start signal | | | | | | | | | |
| External signal input (Terminal 2, 4, JOG, multi-speed selection, etc.) | Input using the RUN-key of the operation panel or FWD/REV of the PU (FR-PU04/FR-PU07) | | | | | | | | | |
| 6 | Switch-over mode Switch among PU operation, external operation, and NET operation while keeping the same operation status. | PU operation mode  External operation mode  NET operation mode  | | | | | | | | |
| 7 | External operation mode (PU operation interlock) X12 signal ON ^① : Operation mode can be switched to the PU operation mode. (output stop during external operation) X12 signal OFF ^① : Operation mode can not be switched to the PU operation mode. | PU operation mode  External operation mode  | | | | | | | | |

^① For the terminal used for the X12 signal (PU operation interlock signal) input, assign "12" in Pr. 178 to Pr. 184 "Input terminal function selection" to assign functions. For Pr. 178 to Pr. 184, refer to section 6.10.1. When the X12 signal is not assigned, function of the MRS signal switches from MRS (output stop) to PU operation interlock signal.

NOTE | Setting value "1" to "4" can be changed in the easy operation mode. (Refer to section 4.3.3.)

5.1.7 Large starting torque and low speed torque are necessary (Advance magnetic flux control, general-purpose magnetic flux vector control) (Pr. 71, Pr. 80, Pr. 81, Pr. 800)

Advanced magnetic flux vector control can be selected by setting the capacity, poles and type of the motor used in Pr. 80 and Pr. 81.

Advanced magnetic flux vector control, general-purpose magnetic flux vector control?

The low speed torque can be improved by providing voltage compensation so that the motor current which meets the load torque to flow. Output frequency compensation (slip compensation) is made so that the motor actual speed approximates a speed command value. Effective when load fluctuates drastically, etc.

General-purpose magnetic flux vector control is the same function as it is for the FR-E500 series. Select this control when operation characteristics as similar as possible are required when replacing from the FR-E500 series. For other cases, select advanced magnetic flux vector control.

| Pr. No. | Name | Initial Value | Setting Range | Description |
|------------|------------------------------|--|---------------------------------------|---|
| 9 | Electronic thermal O/L relay | Rated inverter output current ^① | 0–500A | Set the rated motor current. |
| 71 | Applied motor | 0 | 0/1/3–6/13–16/23/24/40/43/44/50/53/54 | By selecting a standard motor or constant-torque motor, thermal characteristic and motor constants of each motor are set. |
| 80 | Motor capacity | 9999 | 0.1–55kW | Set the applied motor capacity. |
| | | | 9999 | V/f Control |
| 81 | Number of motor poles | 9999 | 2/4/6/8/10 | Set the number of motor poles. |
| | | | 9999 | V/f Control |
| 800 | Control method selection | 20 | 20 | Advanced magnetic flux vector control ^② |
| | | | 30 | General-purpose magnetic flux vector control ^② |

^① Refer to appendix A for the rated inverter output current.

^② Set a value other than "9999" in Pr. 80 and Pr. 81.

NOTES

If the following conditions are not satisfied, select V/F control since malfunction such as insufficient torque and uneven rotation may occur.

- The motor capacity should be equal to or one rank lower than the inverter capacity. (Note that the capacity should be 0.1kW or more.)
- Motor to be used is any of Mitsubishi standard motor, high efficiency motor (SF-JR, SF-HR 0.2kW or more) or Mitsubishi constant-torque motor (SF-JRCA (four-pole), SF-HRCA 0.4kW to 15kW). When using a motor other than the above (other manufacturer's motor), perform offline auto tuning without fail.

Single-motor operation (one motor run by one inverter) should be performed.

The wiring length from inverter to motor should be within 30m. (Perform offline auto tuning in the state where wiring work is performed when the wiring length exceeds 30m.)

Selection method of advanced magnetic flux vector control

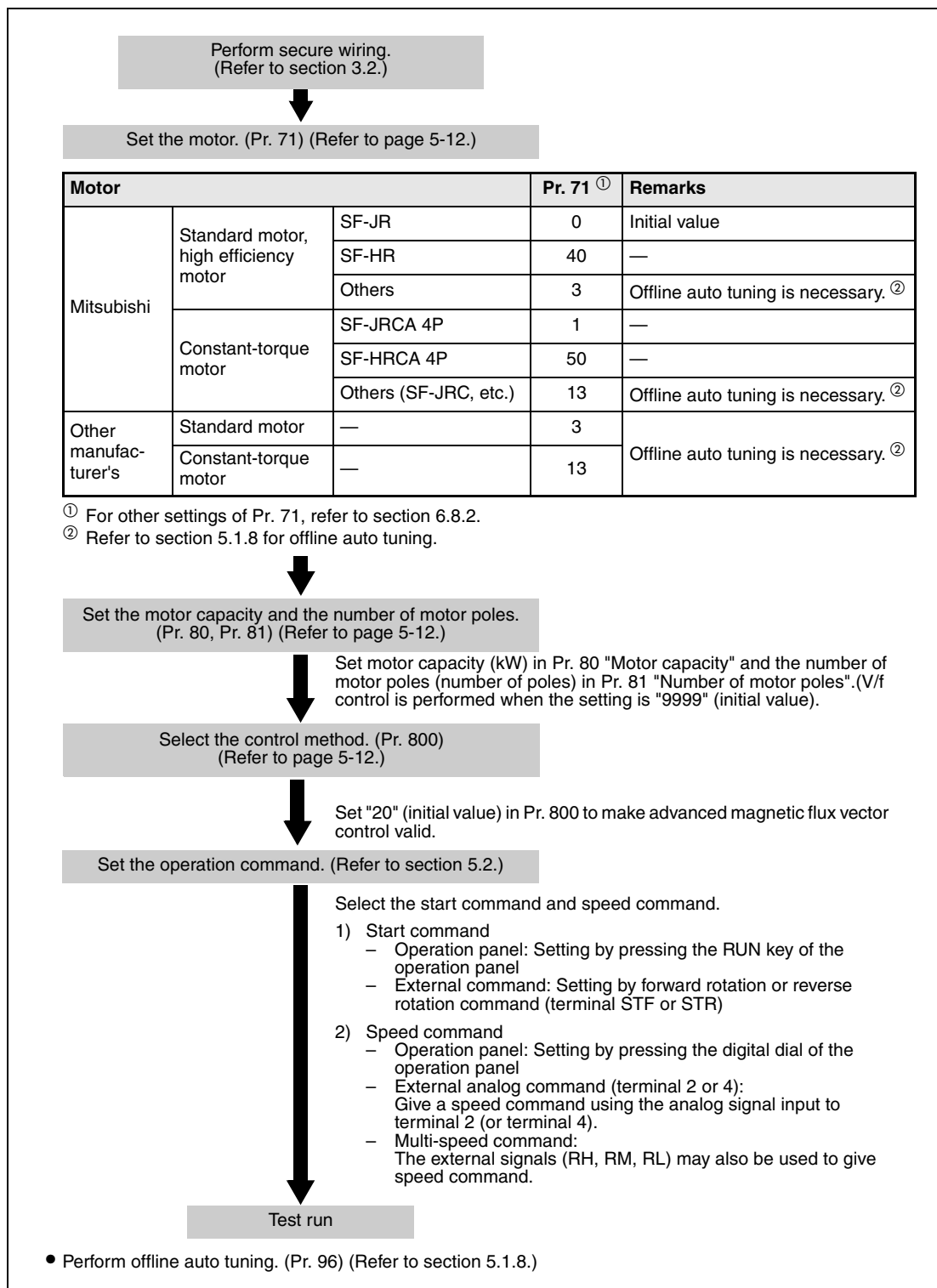

Fig. 5-9: Selection method of advanced magnetic flux vector control

NOTES

Uneven rotation slightly increases as compared to the V/F control. (It is not suitable for machines such as grinding machine and wrapping machine which requires less uneven rotation at low speed.)

Use Pr. 89 to adjust the motor speed fluctuation at load fluctuation. (Refer to page 6-36.)

Selection method of general-purpose magnetic flux vector control

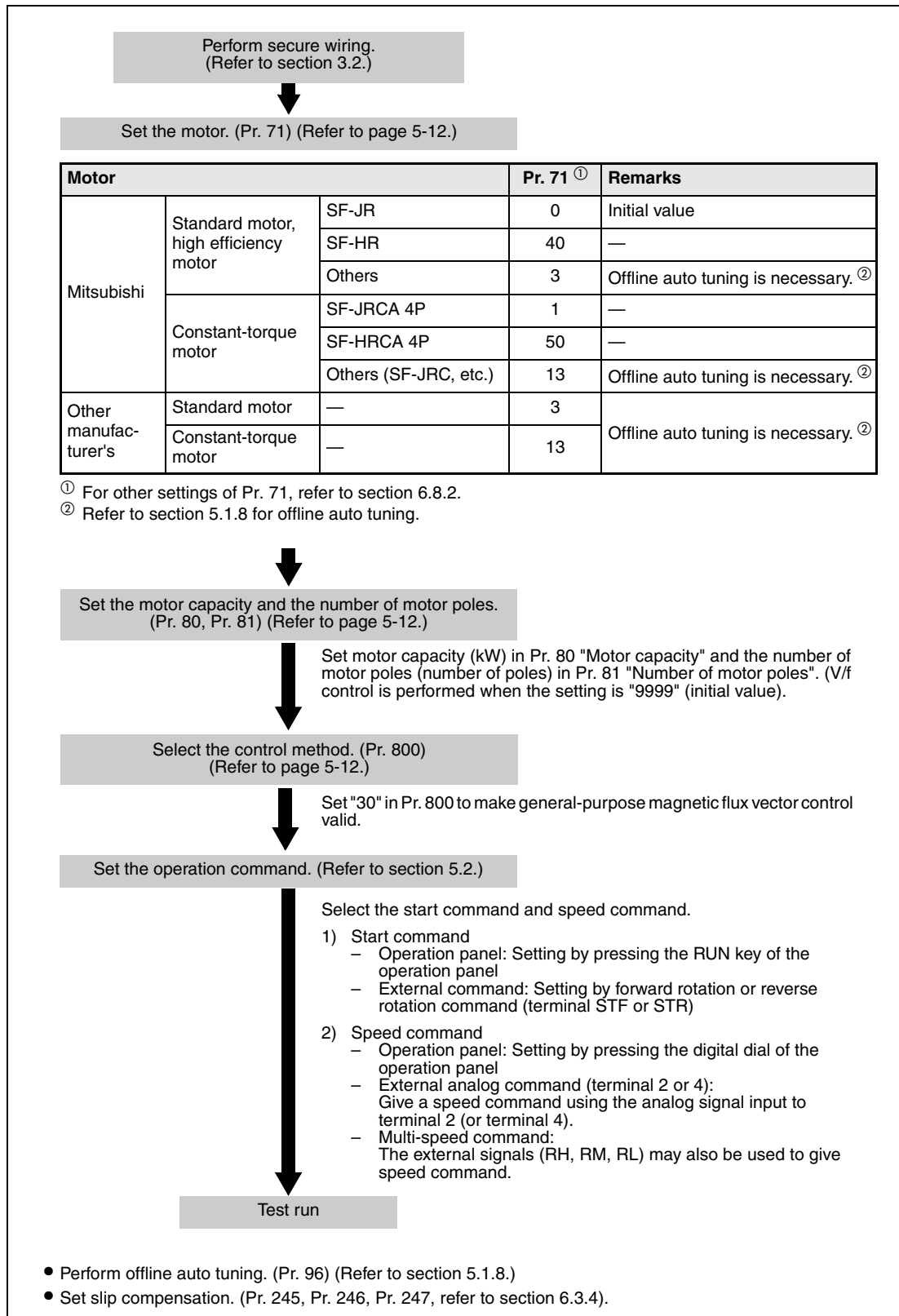

Fig. 5-10: Selection method of general-purpose magnetic flux vector control

5.1.8 To exhibit the best performance of the motor performance (offline auto tuning) (Pr. 9, Pr. 71, Pr. 83, Pr. 84, Pr. 96)

The motor performance can be maximized with offline auto tuning.

What is offline auto tuning?

When performing advanced magnetic flux vector control or general-purpose magnetic flux vector control, the motor can be run with the optimum operating characteristics by automatically measuring the motor constants (offline auto tuning) even when each motor constants differs, other manufacturer's motor is used, or the wiring length is long.

| Pr. No. | Name | Initial Value | Setting Range | Description |
|-----------|--------------------------------|--|--|--|
| 9 | Electronic thermal O/L relay | Rated inverter output current ^① | 0–500A | Set the rated motor current. |
| 71 | Applied motor | 0 | 0/1/3–6/ 13–16/ 23/24/ 40/43/44/50/53/54 | By selecting a standard motor or constant-torque motor, thermal characteristic and motor constants of each motor are set. |
| 83 | Motor rated voltage | 200V/ 400V ^② | 0–1000V | Set the rated motor voltage (V). |
| 84 | Rated motor frequency | 50Hz | 10–120Hz | Set the rated motor frequency (Hz). |
| 96 | Auto tuning setting/ status | 0 | 0 | Offline auto tuning is not performed |
| | | | 1 | Offline auto tuning is performed without motor running (all motor constants) |
| | | | 11 | For general-purpose magnetic flux vector control Offline auto tuning is performed without motor running (motor constant (R1) only) |
| | | | 21 | Offline auto tuning for V/f control (automatic restart after instantaneous power failure (with frequency search)) (refer to section 6.12.1) |

^① Refer to appendix A for the rated inverter output current.

^② The initial value differs according to the voltage class: 200V/400V

NOTES

This function is made valid only when a value other than "9999" is set in Pr. 80 and Pr. 81 and advanced magnetic flux vector control or general-purpose magnetic flux vector control is selected.)

You can copy the offline auto tuning data (motor constants) to another inverter with the PU (FR-PU07).

Even when motors (other manufacturer's motor, SF-JRC, etc.) other than Mitsubishi standard motor, high efficiency motor (SF-JR, SF-HR 0.2kW or more), and Mitsubishi constant-torque motor (SF-JRCA four-pole, SF-HRCA 0.4kW to 15kW) are used or the wiring length is long, using the offline auto tuning function runs the motor with the optimum operating characteristics.

Tuning is enabled even when a load is connected to the motor. As the motor may run slightly, fix the motor securely with a mechanical brake or make sure that there will be no problem in safety if the motor runs (caution is required especially in elevator). Note that tuning performance is unaffected even if the motor runs slightly.

Reading/writing/copy of motor constants tuned by offline auto tuning are enabled.

The offline auto tuning status can be monitored with the operation panel and PU (FR-PU04/FR-PU07).

Before performing offline auto tuning

Check the following before performing offline auto tuning.

- Make sure advanced magnetic flux vector control or general-purpose magnetic flux vector control (Pr. 80, Pr. 81) is selected (refer to section 5.1.7). (Tuning can be performed even under V/f control selected by turning on X18.)
- A motor should be connected. Note that the motor should be at a stop at a tuning start.
- The motor capacity should be equal to or one rank lower than the inverter capacity. (Note that the capacity should be 0.1kW or more.)
- The maximum frequency is 120Hz.
- A high-slip motor, high-speed motor and special motor cannot be tuned.
- As the motor may run slightly, fix the motor securely with a mechanical brake or make sure that there will be no problem in safety if the motor runs (caution is required especially in elevator). Note that tuning performance is unaffected even if the motor runs slightly.

Setting

- ① Select advanced magnetic flux vector control or general-purpose magnetic flux vector control. (Refer to section 5.1.7.)
- ② Set "1" or "11" in Pr. 96 "Auto tuning setting/status".
 - When the setting is "1":
Tune all motor constants without running the motor.
When performing advanced magnetic flux vector control, set "1" to perform tuning.
Depending on the motor type and the inverter capacity it takes approximately 25 to 75s until tuning is completed.
(Excitation noise is produced during tuning.)
 - When the setting is "11":
Tune motor constants (R1) only without running the motor.
When performing general-purpose magnetic flux vector control, set "11" to perform tuning.
It takes approximately 9s until tuning is completed.
- ③ Set the rated motor current (initial value is rated inverter current) in Pr. 9 "Electronic thermal O/L relay". (Refer to page 5-2.)
- ④ Set the rated voltage of motor (initial value is 200V) in Pr. 83 "Rated motor voltage" and rated motor frequency (initial value is 60Hz) in Pr. 84 "Rated motor frequency".
- ⑤ Set Pr. 71 "Applied motor" according to the motor used.

| Motor | | Parameter 71 ① | |
|-----------------------|--|------------------------|----|
| Mitsubishi | Standard motor, high efficiency motor | SF-JR | 3 |
| | | SF-JR 4P-1.5kW or less | 23 |
| | | SF-HR | 43 |
| | | Others | 3 |
| | Constant-torque motor | SF-JRCA 4P | 13 |
| | | SF-HRCA | 53 |
| Others (SF-JRC, etc.) | | 13 | |
| Other manufacturer's | Standard motor | 3 | |
| | Constant-torque motor | 13 | |

Tab. 5-3: Motor selection

- ① For other settings of Pr. 71, refer to the section 6.12.2.

Execution of tuning

**CAUTION:**

Before performing tuning, check the monitor display of the operation panel or parameter unit (FR-PU04/FR-PU07) if the inverter is in the status for tuning. (Refer to Tab. 5-4.) When the start command is turned on under V/f control, the motor starts.

When performing tuning or PU operation, press the RUN key of the operation panel or the FWD or REV key of the parameter unit (FR-PU04/FR-DU07).

For external operation, turn on the run command (STF signal or STR signal). Tuning starts.

NOTES

To force tuning to end, use the MRS or RES signal or press the STOP key of the operation panel. (Turning the start signal (STF signal or STR signal) off also ends tuning.)

During offline auto tuning, only the following I/O signals are valid: (initial value)

- Input terminal <valid signal> MRS, RES, STF, STR
- Output terminal RUN, AM, A, B, C

Note that the progress status of offline auto tuning is output from AM when speed and output frequency are selected.

Since the RUN signal turns on when tuning is started, caution is required especially when a sequence which releases a mechanical brake by the RUN signal has been designed.

When executing offline auto tuning, input the run command after switching on the main circuit power (R/L1, S/L2, T/L3) of the inverter.

Do not perform ON/OFF switching of the second function selection signal (RT) during execution of offline auto tuning. Auto tuning is not executed properly.

Monitor display during auto tuning

Monitor is displayed on the operation panel and parameter unit (FR-PU04/FR-PU07) during tuning as below.

| | Parameter Unit (FR-PU04/FR-PU07) Display | | Operation Panel Indication | |
|--|--|----|----------------------------|----|
| | 1 | 11 | 1 | 11 |
| Setting | | | | |
| Tuning in progress | | | | |
| Normal end | | | | |
| Error end (when inverter protective function operation is activated) | | | | |

Tab. 5-4: Monitor display

NOTE

The set frequency monitor displayed during the offline auto tuning is 0Hz.

Reference: Offline auto tuning time (when the initial value is set)

| Offline Auto Tuning Setting | Time |
|--|---|
| Tune all motor constants (Pr. 96 = 1) | Approximately 25 to 75s (Tuning time differs according to the inverter capacity and motor type.) |
| Tune motor constants (R1) only (Pr. 96 = 11) | Approximately 9s |

Tab. 5-5: Offline auto tuning time (when the initial value is set)

Return to the normal operation mode

When offline auto tuning ends, press the STOP/RESET key of the operation panel during PU operation.

For external operation, turn off the start signal (STF signal or STR signal) once.

This operation resets the offline auto tuning and the PU's monitor display returns to the normal indication. (Without this operation, next operation cannot be started.)

NOTE

Do not change the Pr. 96 setting after completion of tuning (3 or 13). If the Pr. 96 setting is changed, tuning data is made invalid. If the Pr. 96 setting is changed, tuning must be performed again.

If offline auto tuning ended in error (see the table below), motor constants are not set. Perform an inverter reset and restart tuning.

| Error Display | Error cause | Remedy |
|---------------|--|---|
| 8 | Forced end | Set "1" or "11" in Pr. 96 and perform tuning again. |
| 9 | Inverter protective function operation | Make setting again. |
| 91 | Current limit (stall prevention) function was activated. | Set "1" in Pr. 156. |
| 92 | Converter output voltage reached 75% of rated value. | Check for fluctuation of power supply voltage. |
| 93 | – Calculation error – A motor is not connected. | Check the motor wiring and make setting again. |

Tab. 5-6: Value of Parameter 96

When tuning is ended forcibly by pressing the STOP-key or turning off the start signal (STF or STR) during tuning, offline auto tuning does not end normally. (The motor constants have not been set.) Perform an inverter reset and restart tuning.

When using the motor corresponding to the following specifications and conditions, reset Pr. 9 Electronic thermal O/L relay as below after tuning is completed.

- When the rated power specifications of the motor is 200/220V(400/440V) 60Hz, set 1.1 times rated motor current value in Pr. 9.
- When performing motor protection from overheat using a PTC thermistor or motor with temperature detector such as Klixon, set "0" (motor overheat protection by the inverter is invalid) in Pr. 9.

NOTES

The motor constants measured once in the offline auto tuning are stored as parameters and their data are held until the offline auto tuning is performed again.

An instantaneous power failure occurring during tuning will result in a tuning error. After power is restored, the inverter goes into the normal operation mode. Therefore, when STF (STR) signal is on, the motor runs in the forward (reverse) rotation.

Any alarm occurring during tuning is handled as in the ordinary mode. Note that if an error retry has been set, retry is ignored.



CAUTION:

As the motor may run slightly during offline auto tuning, fix the motor securely with a mechanical brake or make sure that there will be no problem in safety if the motor runs. Note that if the motor runs slightly, tuning performance is unaffected.

5.2 PU operation mode

From where is the frequency command given?

- Operation at the frequency set in the frequency setting mode of the operation panel. (Refer to section 5.2.1.)
- Operation using the digital dial as the volume. (Refer to section 5.2.2.)
- Change of frequency with ON/OFF switches connected to terminals. (Refer to section 5.2.3.)
- Frequency setting with a voltage output device. (Refer to section 5.2.4.)
- Frequency setting with a current output device. (Refer to section 5.2.5.)

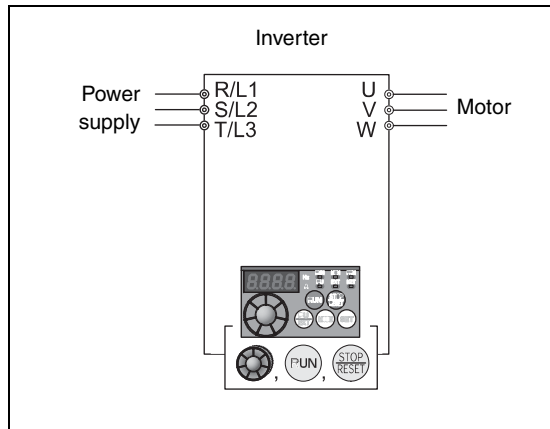
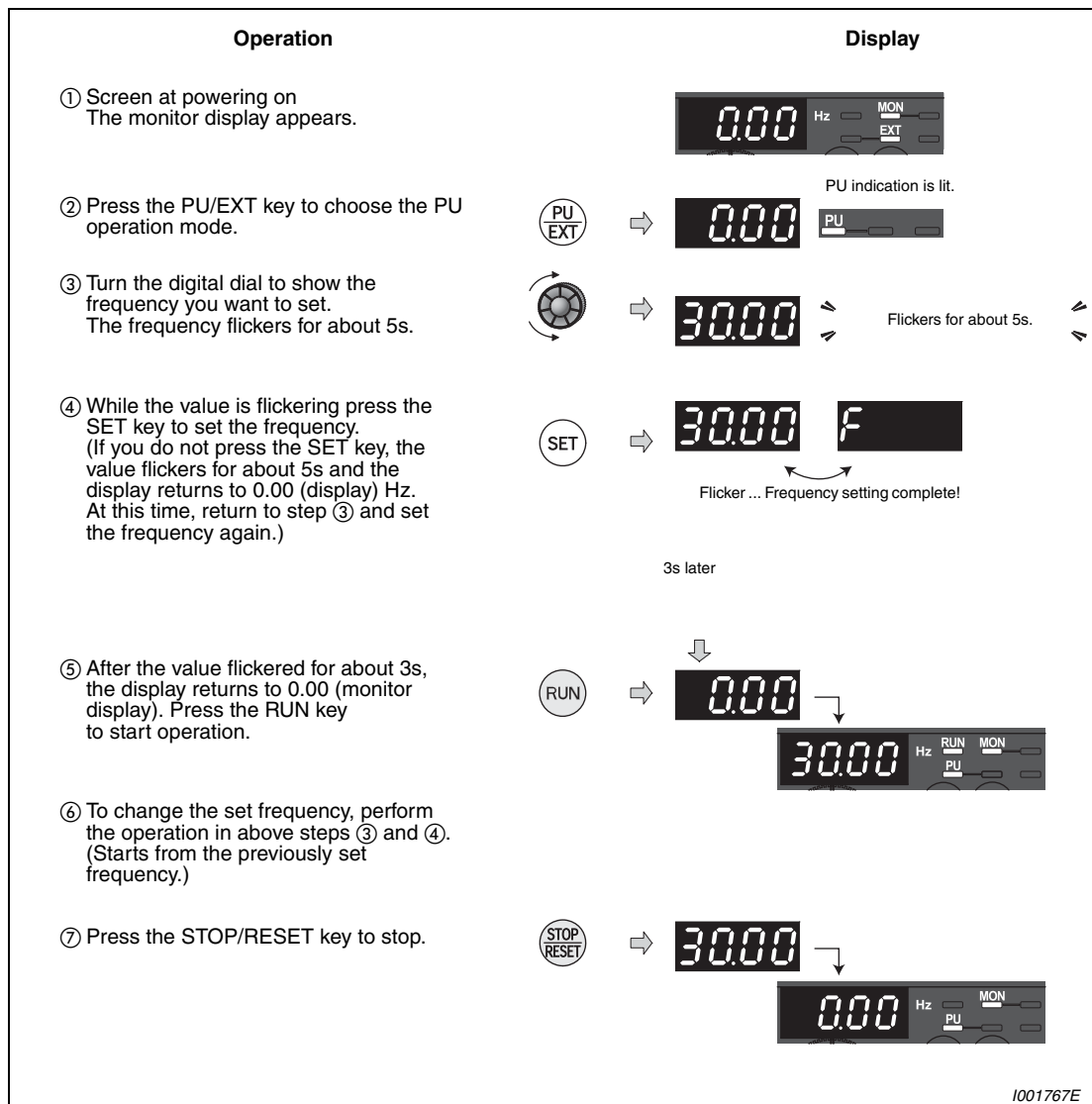

Fig. 5-11:
PU operation mode

I001897E

5.2.1 Set the set frequency to operate

Example ▾ Performing operation at 30Hz



I001767E

Fig. 5-12: Frequency setting with the digital dial



Possible faults:

- Operation cannot be performed at the set frequency.
 - Did you press the SET key within 5s after turning the digital dial?
- The frequency does not change by turning the digital dial.
 - Check to see if the operation mode selected is the external operation mode. (Press the PU/EXT key to change to the PU operation mode.)
- Operation does not change to the PU operation mode.
 - Check that "0" (initial value) is set in Pr. 79 Operation mode selection.
 - Check that the start command is not on.

Change the acceleration time using Pr. 7 (refer to section 5.1.5) and the deceleration time using Pr. 8 (refer to section 5.1.5).

The maximum output frequency is set in Pr. 1. (Refer to section 5.1.4.)

NOTES

Press the digital dial to show the set frequency.

The digital dial can also be used like a potentiometer to perform operation. (Refer to section 5.2.2).

Use Pr. 295 "Magnitude of frequency change setting" to change the frequency setting increments of the digital dial.

5.2.2 Use the digital dial like a potentiometer to perform operation

- Set "1" (setting dial potentiometer mode) in Pr. 161 "Frequency setting/key lock operation selection".

Example ▾

Change the frequency from 0Hz to 50Hz during operation.

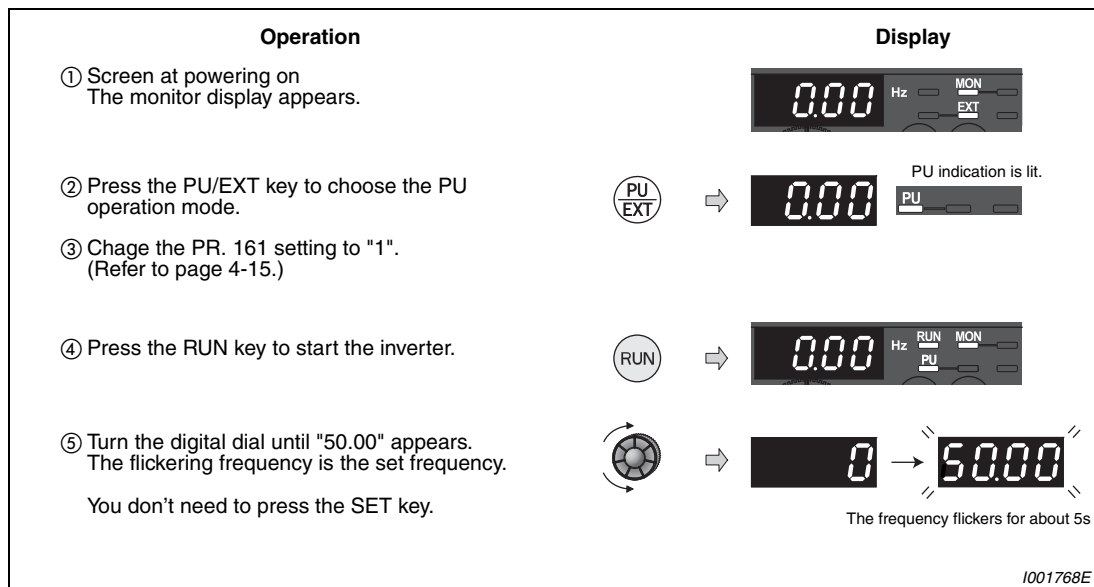

Fig. 5-13: Use the digital dial like a potentiometer to perform operation

NOTES

If flickering "50.00" turns to "0.0", the Pr. 161 "Frequency setting/key lock operation selection" setting may not be "1".

Independently of whether the inverter is running or at a stop, the frequency can be set by merely turning the digital dial.

Use Pr. 295 "Magnitude of frequency change setting" to change the frequency setting increments of the digital dial.



5.2.3 Use switches to give the frequency command (multi-speed setting)

In frequency inverters of the FR-E700 series up to 15 frequency setpoints (and thus rpms and speeds) can be selected via the RH, RM, RL and REX terminals. Manually activated switches or relay outputs of a programmable logic controller (PLC), for example, can be used to select a frequency.

- Pr. 79 "Operation mode selection" must be set to "4" (external/PU combined operation mode 2).
- Use the RUN key to give a start command.
- The initial values of the terminals RH, RM, RL are 50Hz, 30Hz, and 10Hz. (Refer to section 5.3.2 to change frequencies using Pr. 4, Pr. 5 and Pr. 6.)
- Three setpoints can be selected by separately switching on the signals to the RH, RM and RL terminals. The selection of the fourth to the seventh fixed frequency is possible through the combination of signals of these inputs (see diagram below). The setpoints are determined by parameters 24 to 27. The REX terminal is used to select the 8th to the 15th rpm/ speed (section 6.6.1).

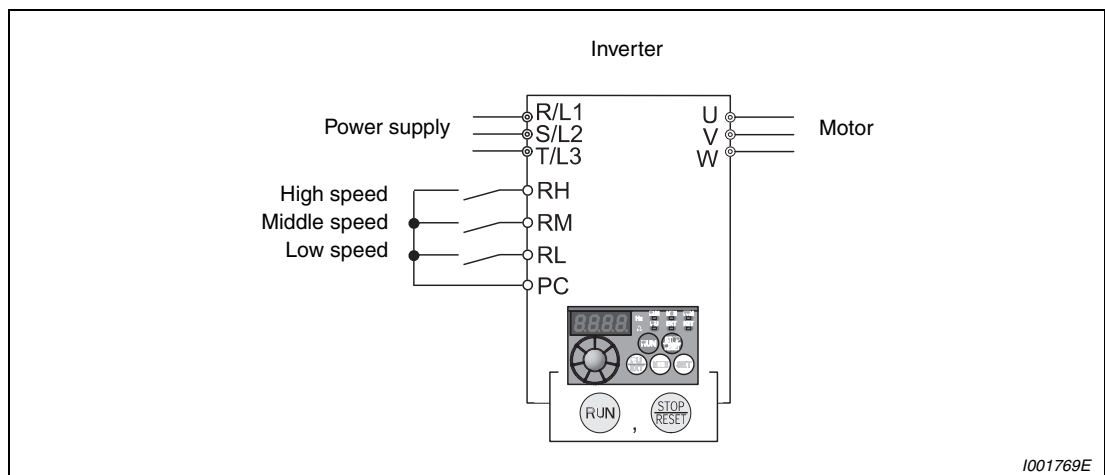

Fig. 5-14: Use switches to give the frequency command

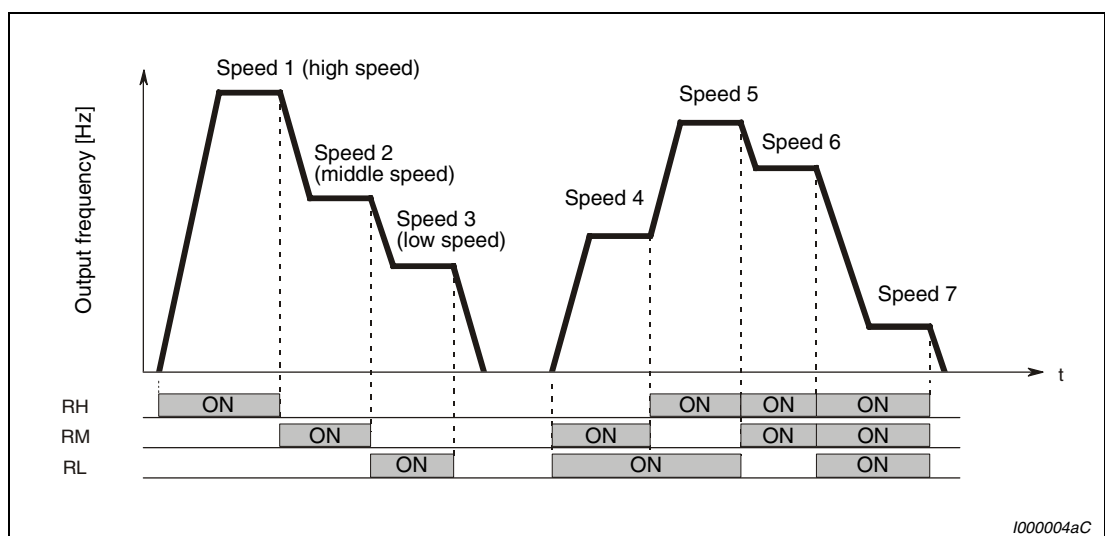

Fig. 5-15: Multi-speed selection by external terminals

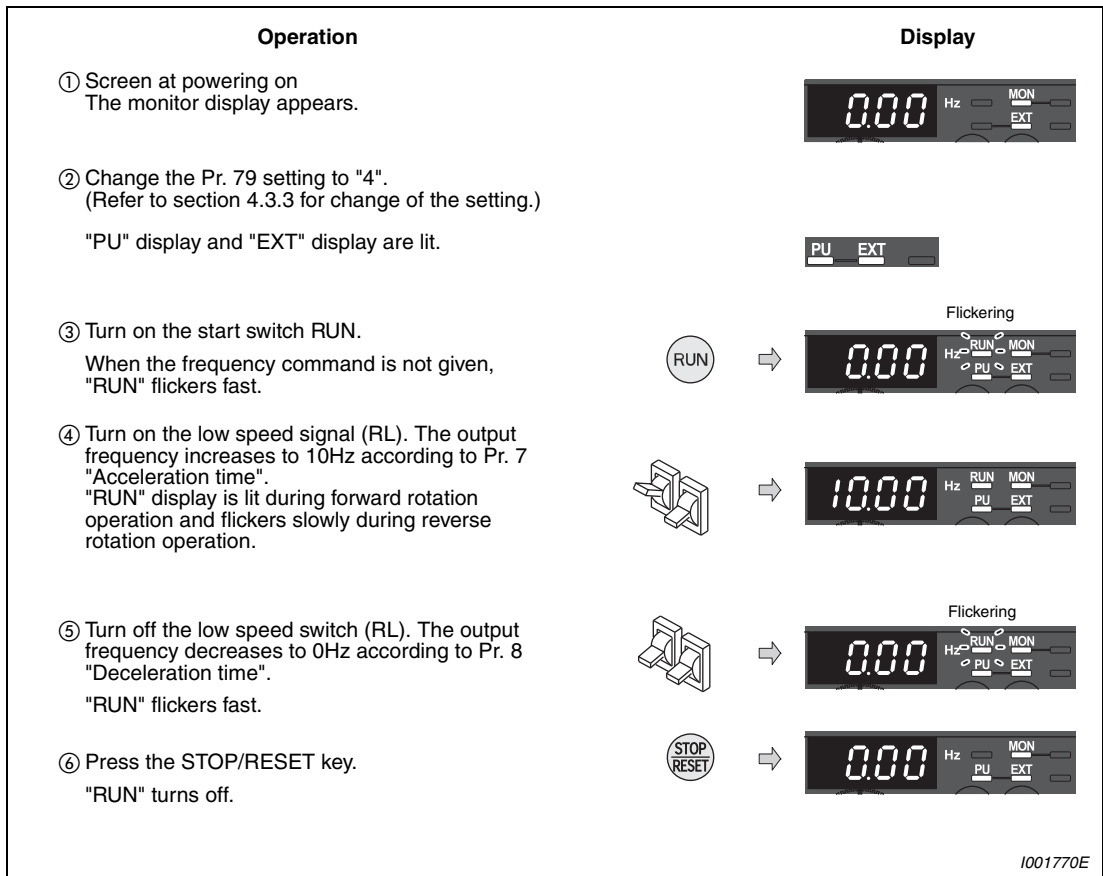

Fig. 5-16: Operate the inverter by using multi-speed setting

Possible faults:

- 50Hz for the RH, 30Hz for the RL and 10Hz for the RL are not output when they are turned on.
 - Check for the setting of Pr. 4, Pr. 5, and Pr. 6 once again.
 - Check for the setting of Pr. 1 "Maximum frequency" and Pr. 2 "Minimum frequency" once again. (Refer to section 5.1.4.)
 - Check that Pr. 180 "RL terminal function selection" = "0", Pr. 181 "RM terminal function selection" = "1", Pr. 182 "RH terminal function selection" = "2" and Pr. 59 "Remote function selection" = "0" (all are initial values).
- RUN lamp is not lit.
 - Check that wiring is correct. Check the wiring once again.
 - Check for the Pr. 79 setting once again. (Pr. 79 must be set to "4".) (Refer to section 5.1.6.)

NOTE

Refer to section 5.3.2 to change the running frequency at each terminal in Pr. 4 "Multi-speed setting (highspeed)", Pr. 5 "Multi-speed setting (middle speed)", and Pr. 6 "Multi-speed setting (low speed)".

5.2.4 Perform frequency setting by analog voltage input

In this type of setpoint selection a potentiometer is connected to the frequency inverter. The potentiometer is supplied with a voltage of 5V through terminal 10 of the frequency inverter.

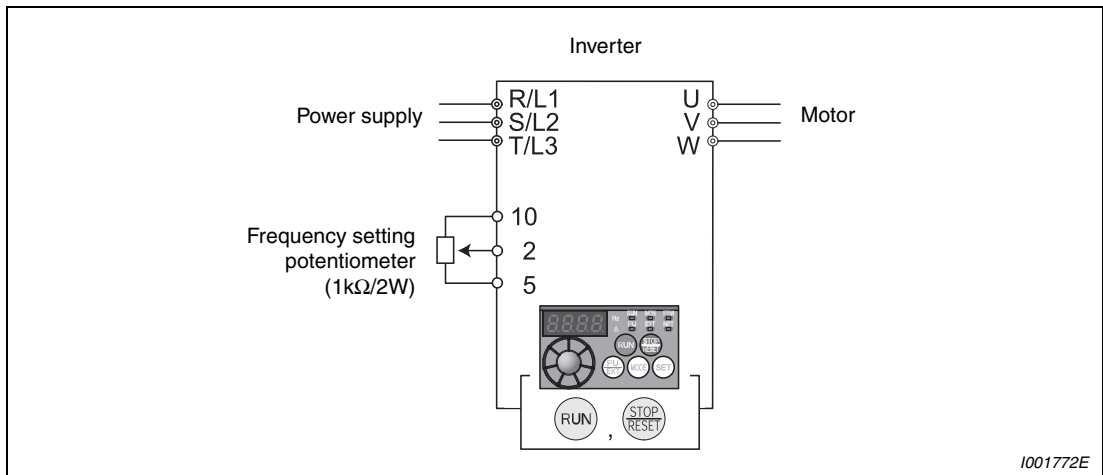

Fig. 5-17: Frequency setting by analog voltage input

- Pr. 79 "Operation mode selection" must be set to "4" (external/PU combined operation mode 2).
- Use the RUN key to give a start command.

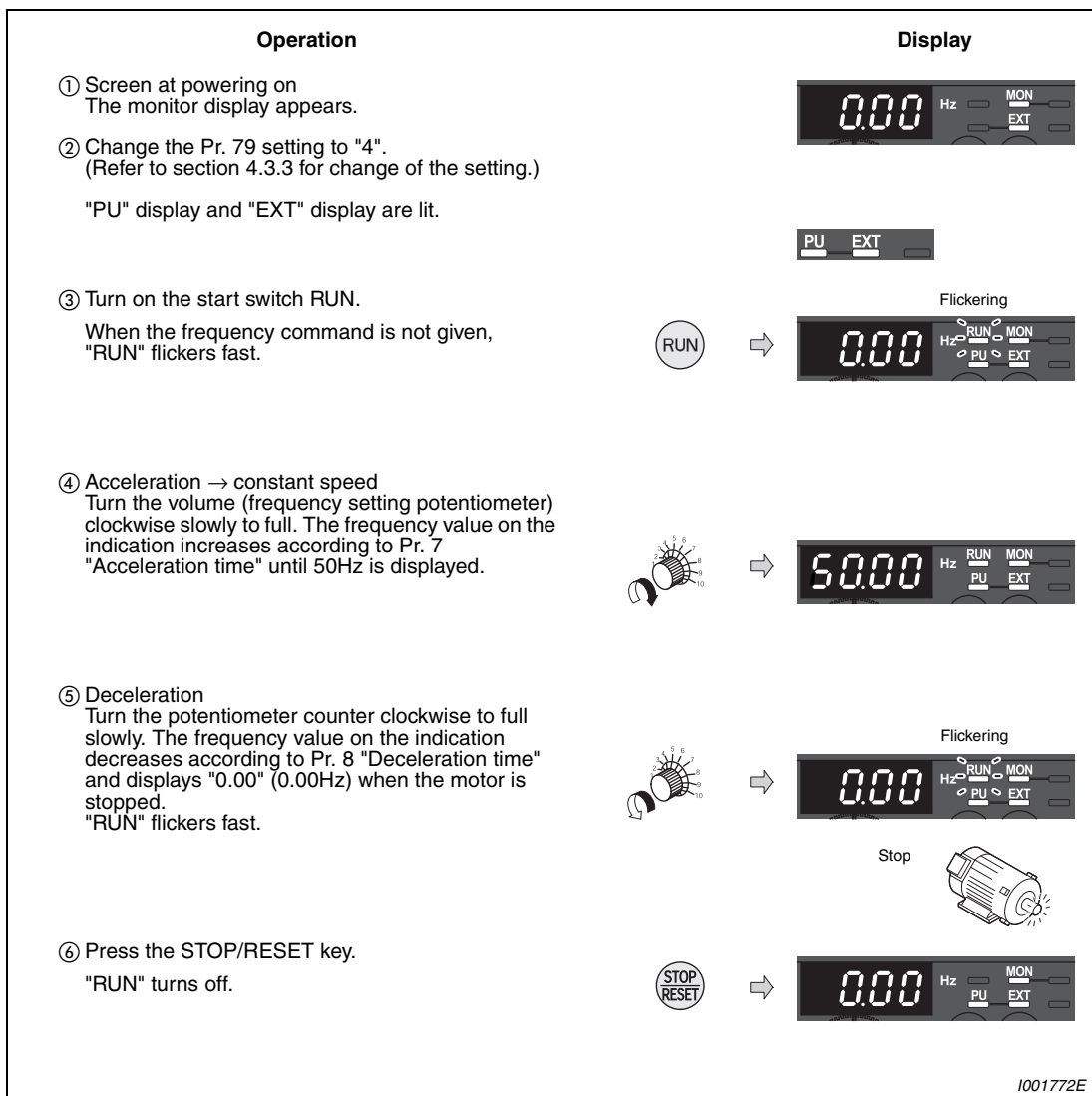

Fig. 5-18: Operate the inverter by using the analog voltage input

NOTES

Change the frequency (50Hz) of the maximum value of potentiometer (at 5V) by adjusting the frequency in Pr. 125 "Terminal 2 frequency setting gain frequency". (Refer to section 5.3.4.)

Change the frequency (0Hz) of the minimum value of potentiometer (at 0V) by adjusting the frequency in calibration parameter C2 "Terminal 2 frequency setting bias frequency". (Refer to section 6.16.3.)

5.2.5 Perform frequency setting by analog current input

An external current source is connection to the frequency inverter for setpoint default setting.

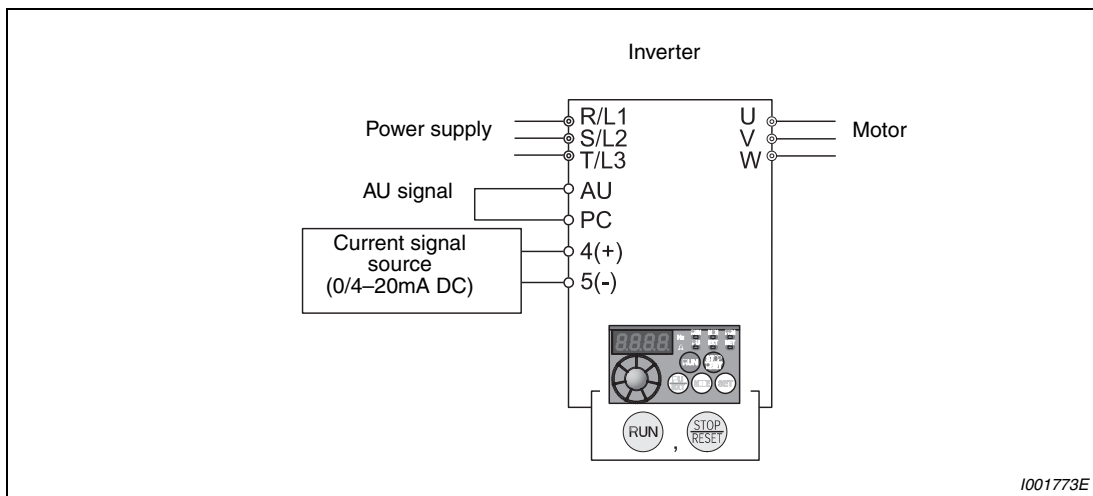

Fig. 5-19: Frequency setting by analog current input

- Pr. 79 "Operation mode selection" must be set to "4" (external/PU combined operation mode 2).
- Turn the AU signal on.
- Use the RUN key to give a start command.

NOTE

For the analog current input (0/4 to 20 mA) to become effective for setpoint default setting, the AU signal on the AU terminal must be activated. This is done, for example, by means of a bridge as shown in Fig. 5-19.

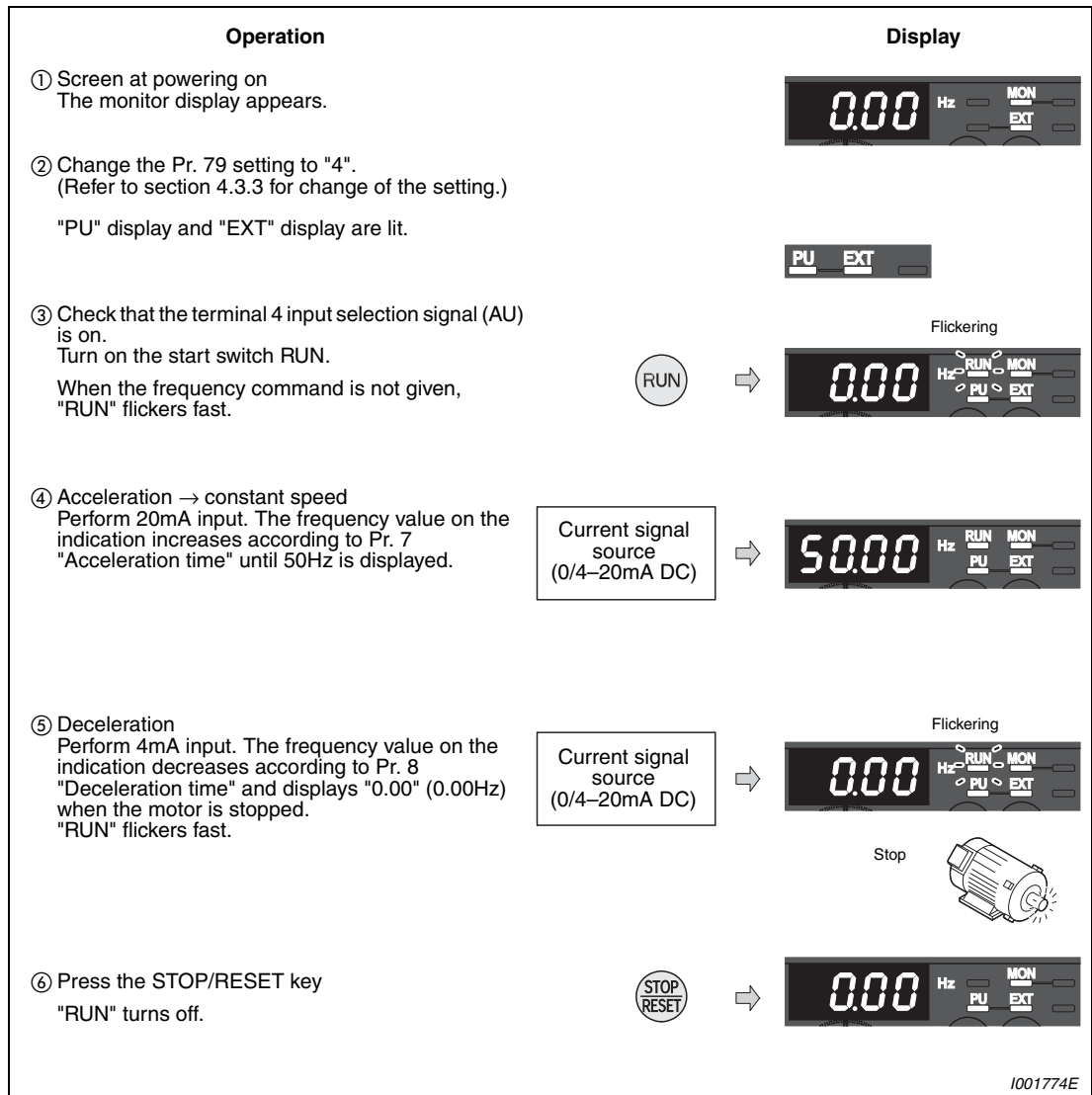

Fig. 5-20: Operate the inverter by using the analog current input

NOTES

One of Pr. 178 to Pr. 184 "AU terminal function selection" must be set to "4" (AU signal) (initial value). (Refer to section 6.10.1.)

Change the frequency (50Hz) at the maximum value of potentiometer (at 20mA) by adjusting the frequency in Pr. 126 "Terminal 4 frequency setting gain frequency". (Refer to section 5.3.6).

Change the frequency (0Hz) at the minimum value of potentiometer (at 4mA) by adjusting the frequency in calibration parameter C5 "Terminal 4 frequency setting bias frequency". (Refer to section 6.16.3.)

5.3 External operation

From where is the frequency command given?

- Operation at the frequency set in the frequency setting mode of the operation panel. (Refer to section 5.3.1.)
- Give a frequency command by switch (multi-speed setting). (Refer to section 5.3.2.)
- Perform frequency setting by a voltage output device. (Refer to section 5.3.3.)
- Perform frequency setting by a current output device. (Refer to section 5.3.4.)

5.3.1 Use the set frequency set by the operation panel (Pr. 79 = 3)

- Set "3" in Pr. 79 (External/PU combined operation mode 1).
- Switch terminal STF (STR)-PC on to give a start command.
- Refer to section 5.2.1 for the set frequency by the operation panel.

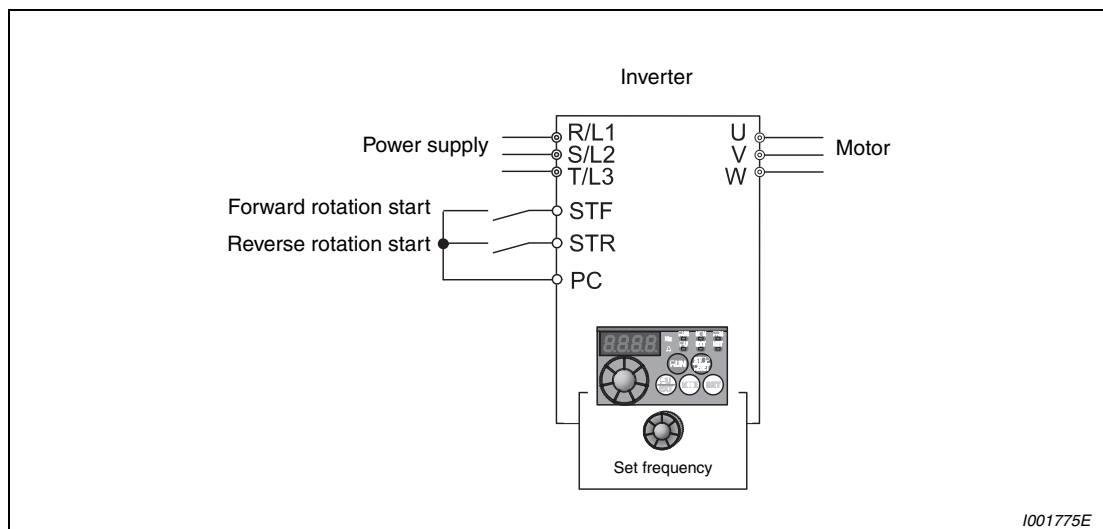

Fig. 5-21: External operation

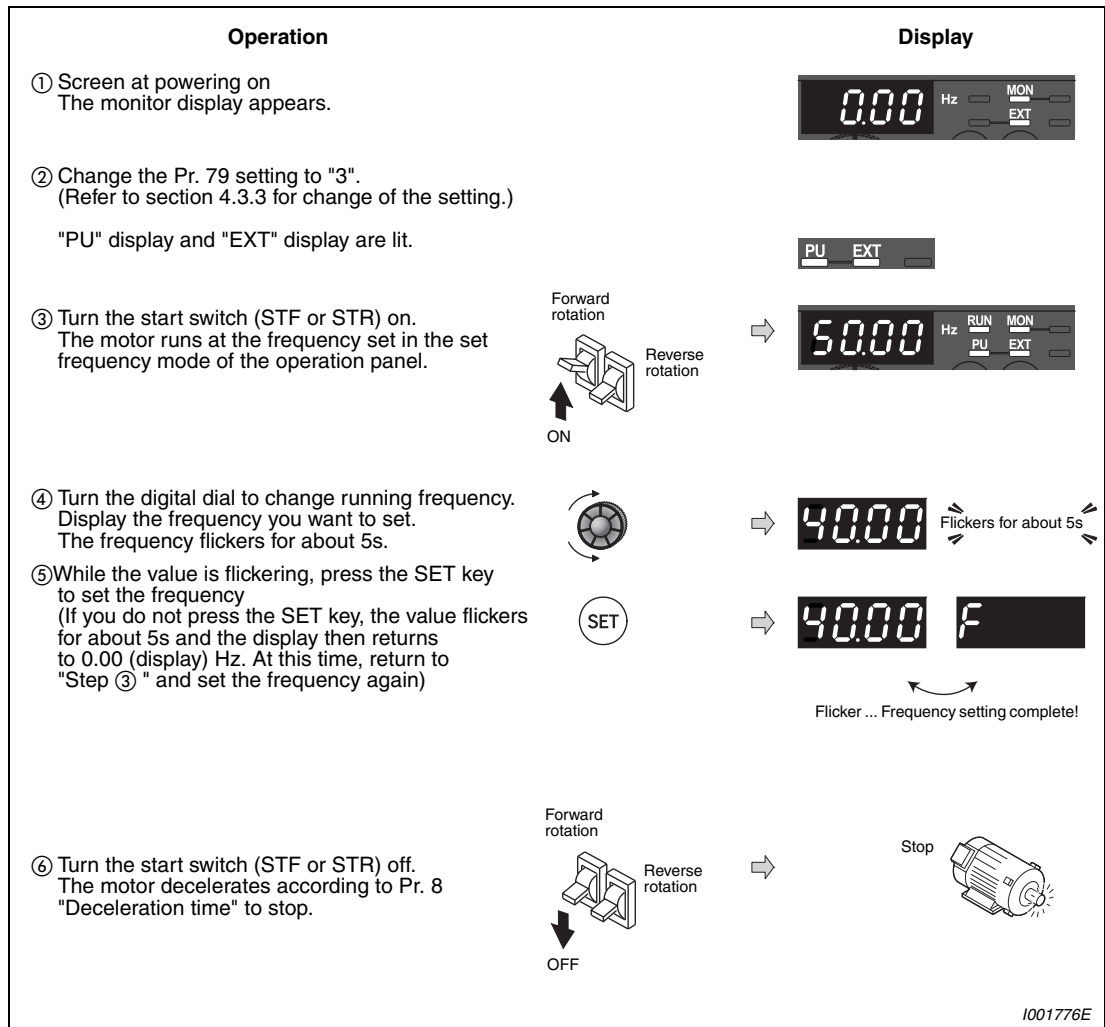

Fig. 5-22: Operate the inverter by using external signals

NOTES

Pr. 178 "STF terminal function selection" must be set to "60" (or Pr. 179 "STR terminal function selection" must be set to "61"). (All are initial values.)

When Pr. 79 "Operation mode selection" is set to "3", multi-speed operation is also made valid. (Refer to section 5.3.2.)

Possible faults:

- Pressing th STOP/RESET key of the operation panel changed the display
- Turn the start switch (STF or STR) off.
- The display can be reset by PU/EXT.

5.3.2 Use switches to give a start command and a frequency command (multi-speed setting) (Pr. 4 to Pr. 6)

- Start command by terminal STF (STR)-PC.
- Frequency command by terminal RH, RM, RL and STR-PC.
- "EXT" must be lit. (When "PU" is lit, switch it to "EXT" with the PU/EXT key.)
- The initial values of the terminals RH, RM, RL are 50Hz, 30Hz, and 10Hz. (Use Pr. 4, Pr. 5 and Pr. 6 to change.)
- Operation at 15-speed can be performed by turning two (or three) terminals simultaneously. (Refer to section 6.6.1.)

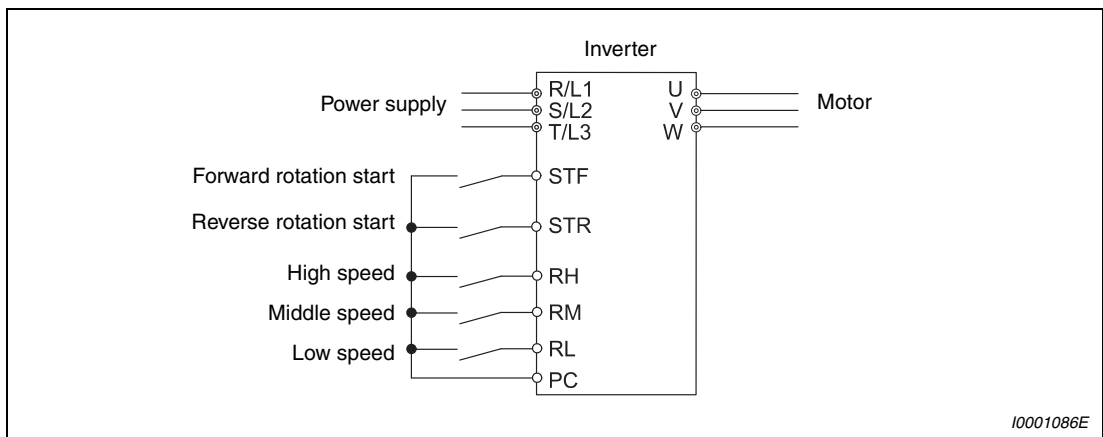

Fig. 5-23: Frequency and start command by switches

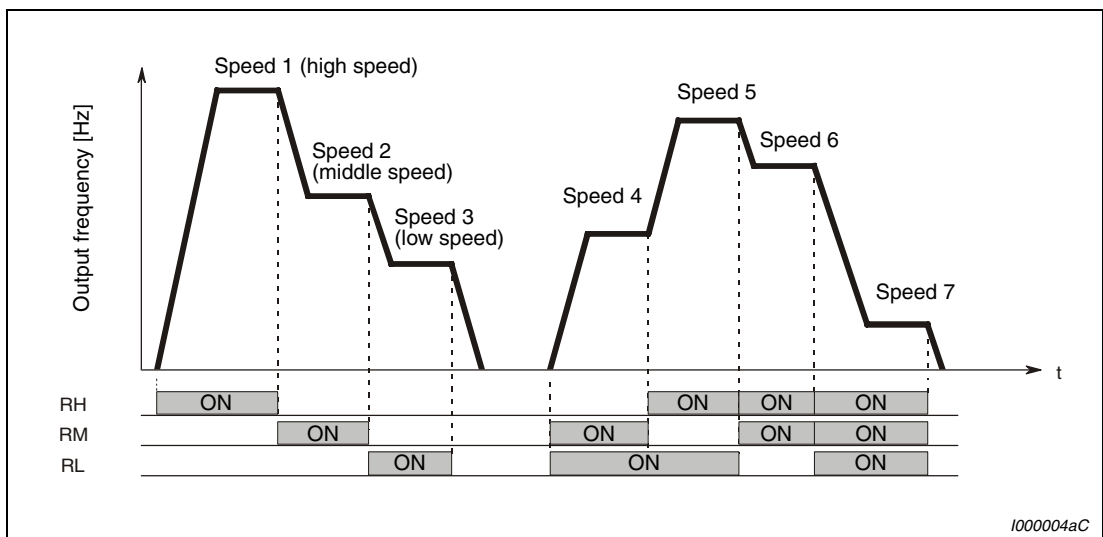

Fig. 5-24: Multi-speed selection by external terminals

Example ▽

Set "40Hz" in Pr. 4 "Multi-speed setting (high speed)" and turn on terminals RH and STF (STR)-PC to operate.

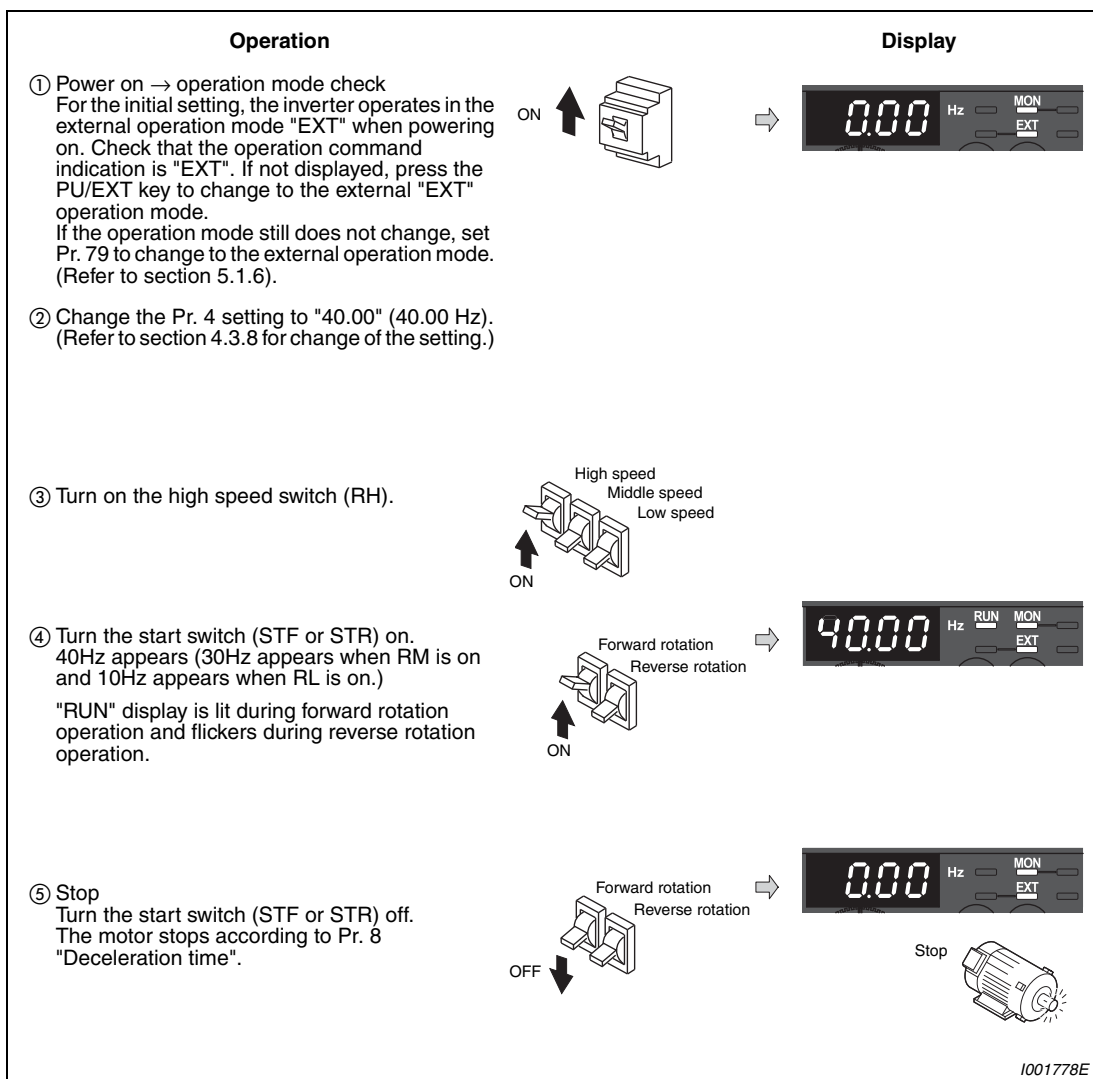

Fig. 5-25: Operate the inverter by using external signals



Possible faults:

- The EXT lamp is not lit even when the PU/EXT key is pressed.
 - Switchover of the operation mode with is valid when Pr. 79 = 0 (initial value).
- 50Hz, 30Hz and 10Hz are not output from RH, RM and RL respectively when they are turned on.
 - Check for the setting of Pr. 4, Pr. 5, and Pr. 6 once again.
 - Check for the setting of Pr. 1 "Maximum frequency" and Pr. 2 "Minimum frequency" once again. (Refer to section 5.1.4.)
 - Check for the Pr. 79 setting once again. (Pr. 79 must be set to "0" or "2".) (Refer to section 5.1.6.)
 - Check that Pr. 180 "RL terminal function selection" = "0", Pr. 181 "RM terminal function selection" = "1", Pr. 182 "RH terminal function selection" = "2" and Pr. 59 "Remote function selection" = "0". (All are initial values.)
- The RUN lamp is not lit.
 - Check that wiring is correct. Check it again.
 - Check that "60" is set in Pr. 178 "STF terminal function selection" (or "61" is set in Pr. 179 "STR terminal function selection"). (All are initial values.)

NOTE

External operation is fixed by setting "2" (external operation mode) in Pr. 79 "Operation mode selection" when you do not want to take time pressing the PU/EXT key or when you want to use the current start command and frequency command.

5.3.3 Perform frequency setting by analog voltage input

The frequency setting potentiometer is supplied with 5V of power from the inverter (terminal 10).

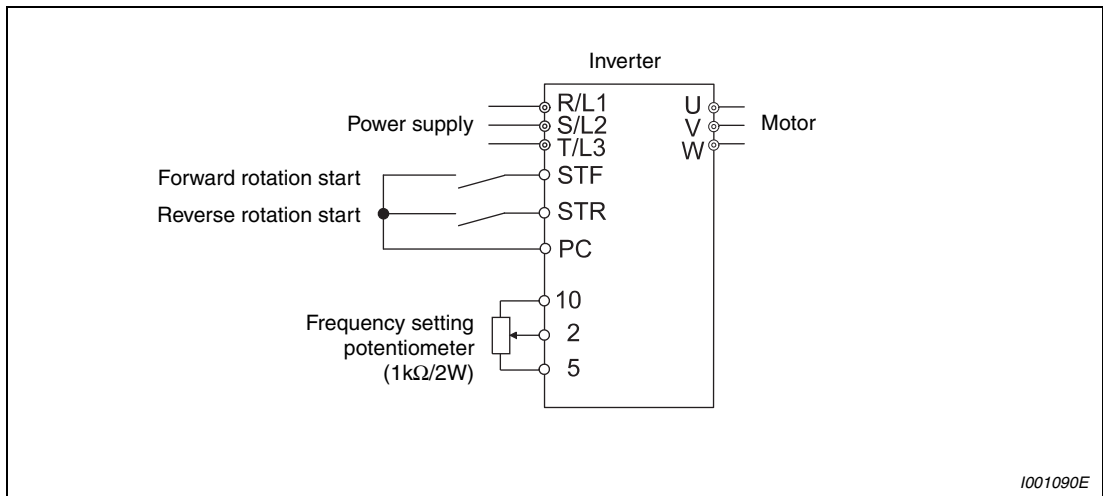

Fig. 5-26: Frequency setting by analog voltage input

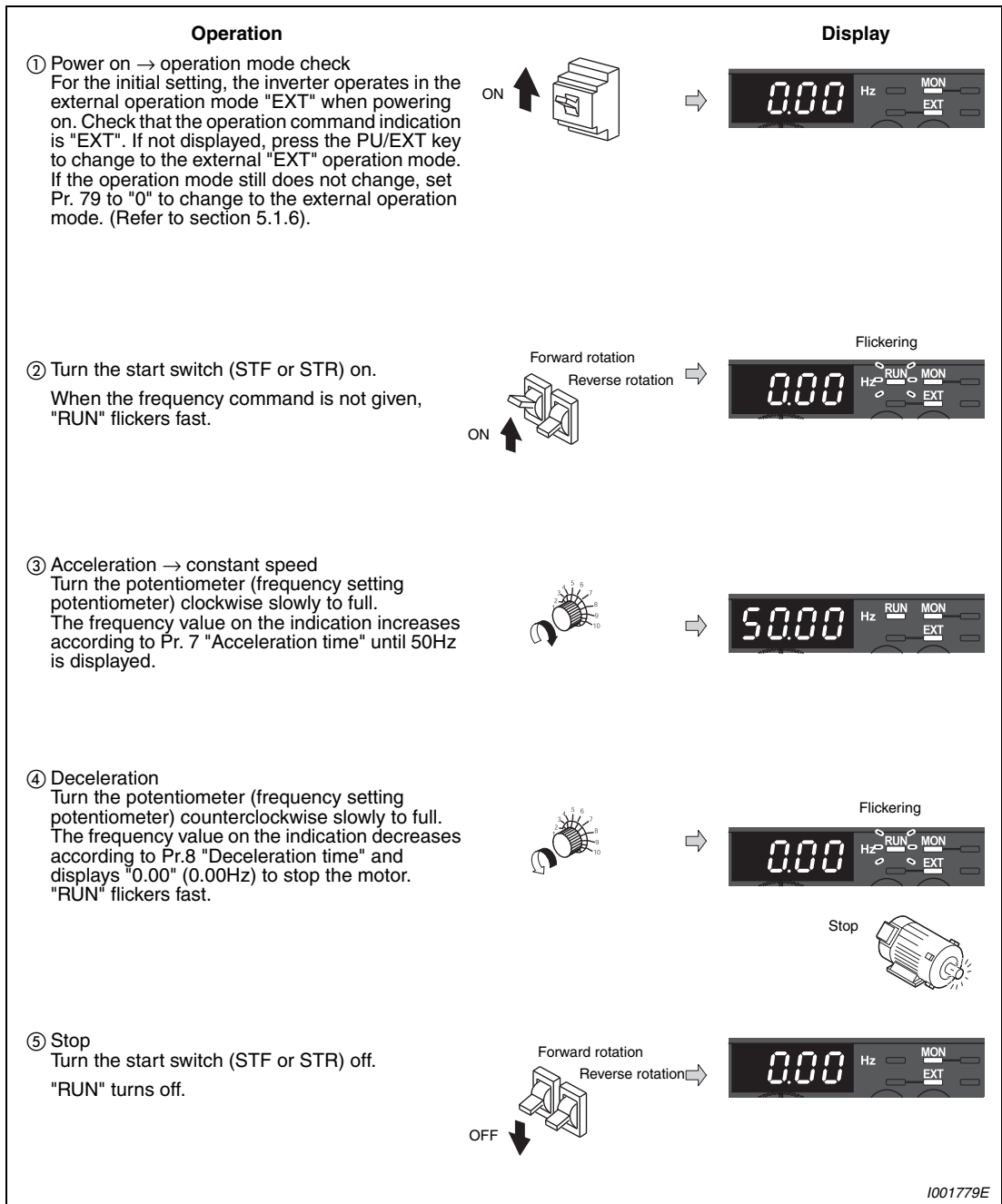

Fig. 5-27: Operate the inverter by using the analog voltage input

NOTES

When you want to operate in the external operation mode always at powering on or when you want to save the trouble of input, set "2" (external operation mode) in Pr. 79 "Operation mode selection" to choose external operation mode always.

Pr. 178 "STF terminal function selection" must be set to "60" (or Pr. 179 "STR terminal function selection" must be set to "61"). (All are initial values.)

Change the frequency (0Hz) of the minimum value of potentiometer (at 0V) by adjusting the frequency in calibration parameter C2 "Terminal 2 frequency setting bias frequency". (Refer to section 6.16.3.)

Possible faults:

- The motor will not rotate.
 - Check that the EXT lamp is lit. The external operation mode is valid when Pr. 79 = 0 (initial value). Use the PU/EXT key to change into the external operation mode.
 - Check that wiring is correct. Check once again.

5.3.4 Change the frequency (40Hz) of the maximum value of potentiometer (at 5V)

Example ▽

The frequency of the maximum analog voltage of the potentiometer (at 5V) has to be changed from the initial setting of 50Hz to 40 Hz. Set 40Hz in Pr. 125.

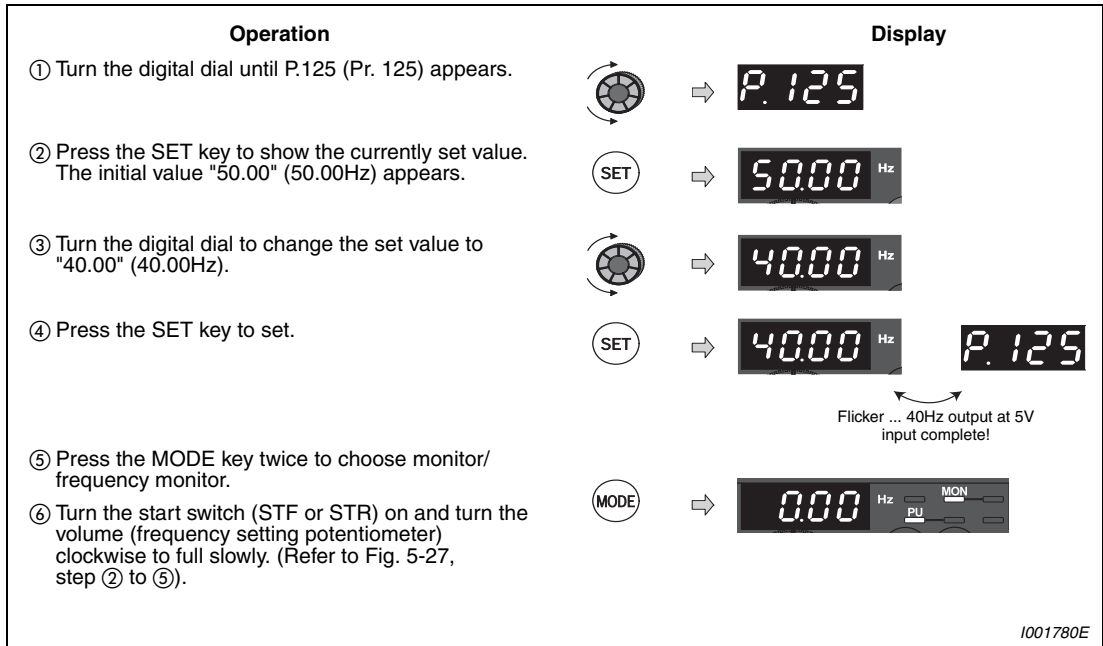
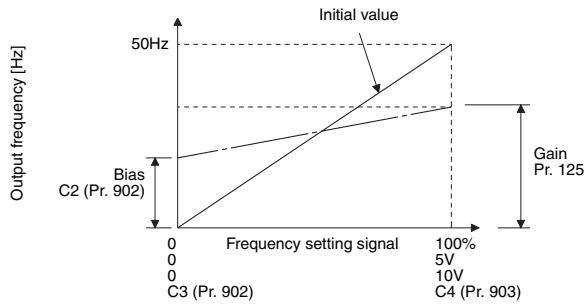

Fig. 5-28: Change the frequency of the maximum analog value



NOTES

Set the frequency at 0V using calibration parameter C2.



As other adjustment methods of frequency setting voltage gain, there are methods to adjust with a voltage applied to across terminals 2-5 and adjust at any point without a voltage applied. (Refer to section 6.16.3 for the setting method of calibration parameter C4.)

5.3.5 Perform frequency setting by analog current input

An external current source is connection to the frequency inverter for setpoint default setting.

- Switch terminal STF (STR)-PC on to give a start command.
- Turn the AU signal on.
- Pr. 79 "Operation mode selection" must be set to "2" (external operation mode).

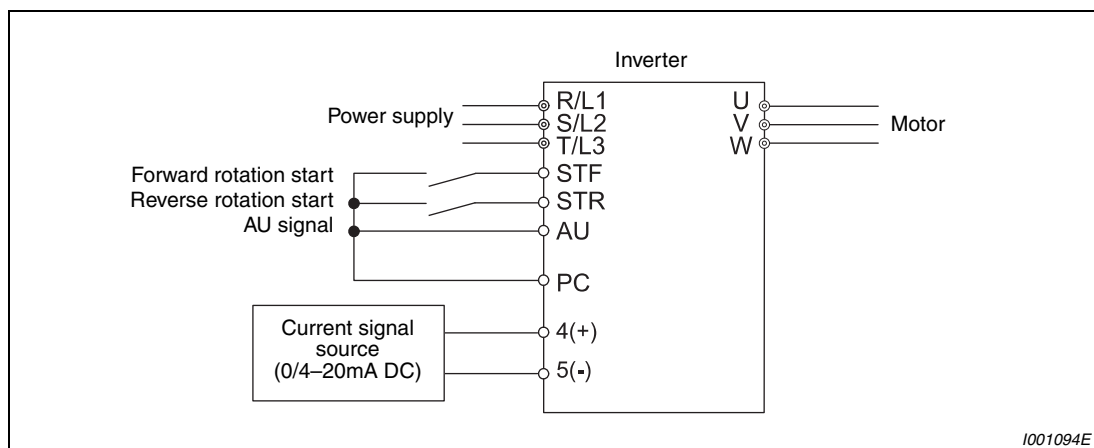

Fig. 5-29: Frequency setting by analog current input

NOTE

For the analog current input (0/4 to 20 mA) to become effective for setpoint default setting, the AU signal on the AU terminal must be activated. This is done, for example, by means of a bridge as shown in Fig. 5-29.

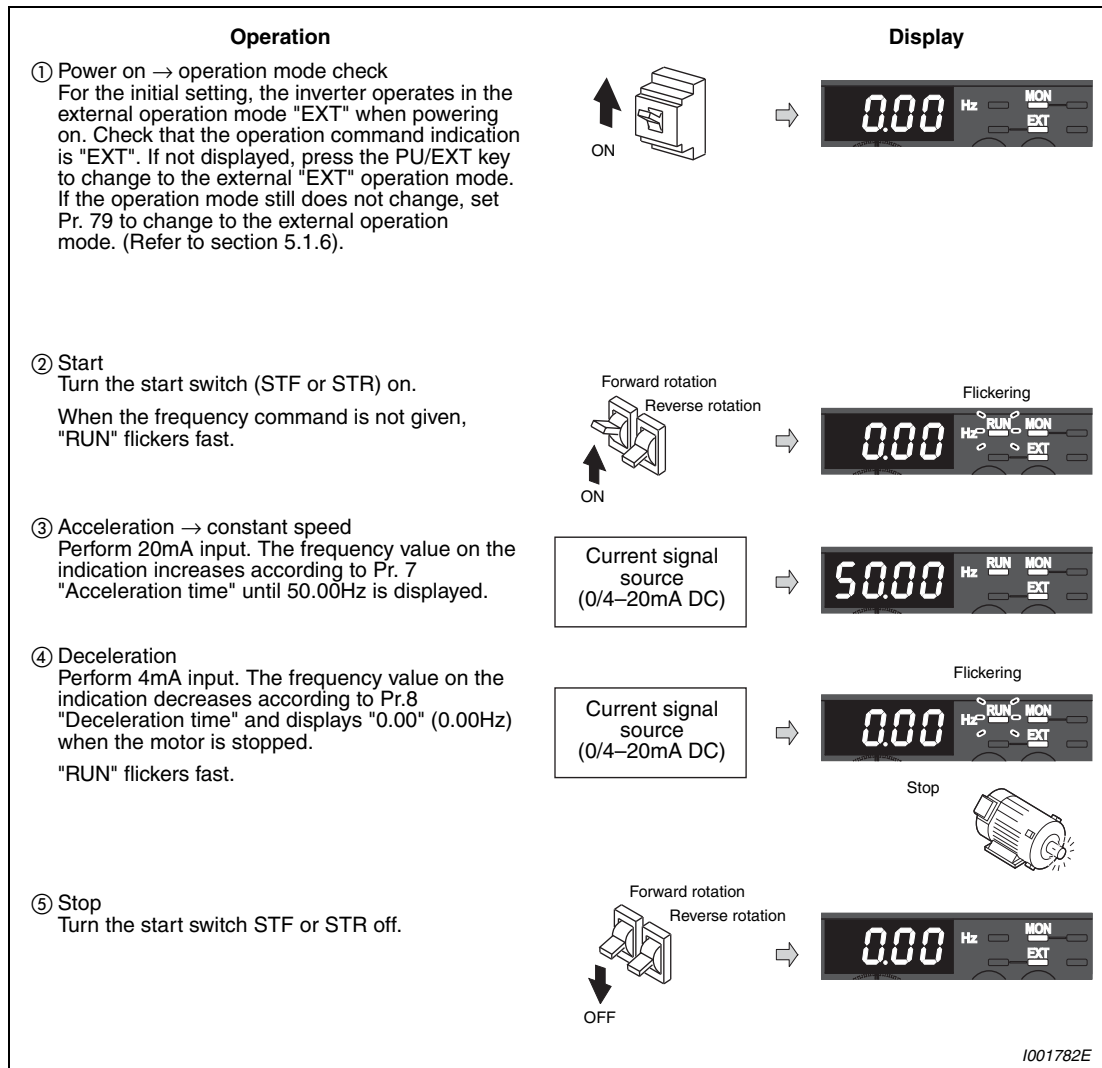

Fig. 5-30: Operate the inverter by using the analog current input

NOTE

One of Pr. 178 to Pr. 184 "AU terminal function selection" must be set to "4" (AU signal) (initial value). (Refer to section 6.10.1.)

Possible faults:

- The motor will not rotate.
 - Check that the EXT lamp is lit. The external operation mode is valid when Pr. 79 = 0 (initial value) or 2. Use the PU/EXT key to change into the external operation mode.
 - The AU signal must be turned on.
 - Check that wiring is correct. Check once again.

NOTE

Change the frequency (0Hz) of the minimum value of potentiometer (at 4mA) by adjusting the frequency in calibration parameter C5 "Terminal 4 frequency setting bias frequency". (Refer to section 6.16.3.)

5.3.6 Change the frequency (40Hz) of the maximum value of potentiometer (at 20mA)

Example ▽

The frequency of the maximum analog current of the potentiometer (at 20mA) has to be changed from the initial setting of 50Hz to 40 Hz. Set 40Hz in Pr. 126.

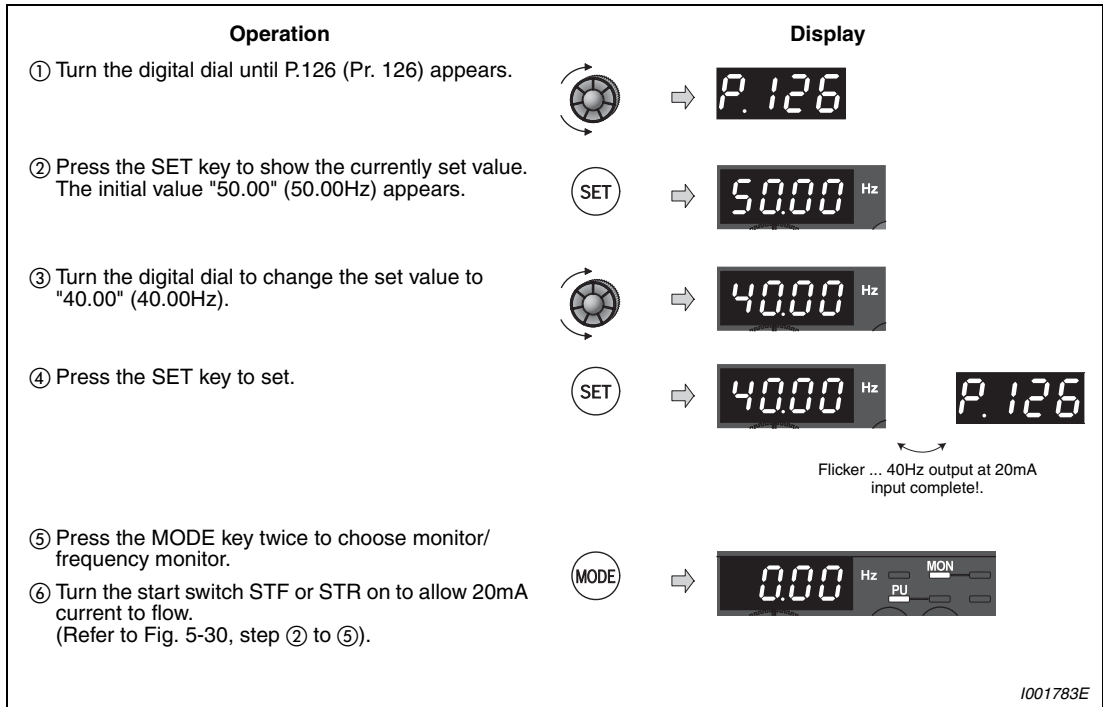
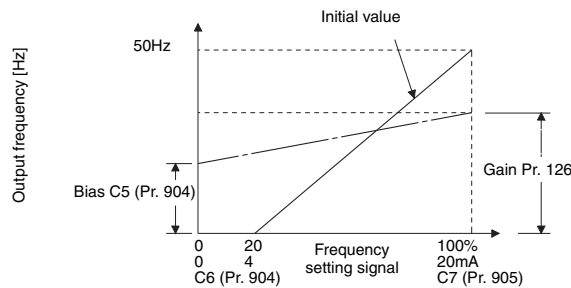

Fig. 5-31: Change the frequency of the maximum analog value



NOTES

Set the frequency at 4mA using calibration parameter C5.



As other adjustment methods of frequency setting current gain, there are methods to adjust with a current flowing in the terminals 4-5 and adjust at any point without a current flowing. (Refer to section 6.16.3 for the setting method of calibration parameter C7.)

When performing a high speed operation at 120Hz or more, setting of Pr. 18 "High speed maximum frequency" is necessary. (Refer to section 6.4.1.)

6 Parameter

6.1 Parameter overview

For simple variable-speed operation of the inverter, the initial setting of the parameters may be used as they are. Set the necessary parameters to meet the load and operational specifications. Parameter setting, change and check can be made from the operation panel.

⊙ indicates simple mode parameters. (initially set to extended mode)

The abbreviations in the explanations below are as follows:

 V/f control

 Advanced magnetic flux vector control

 General-purpose magnetic-flux vector control

Parameters without any indication are valid for all control. The half-tone screened parameters allow its setting to be changed during operation even if "0" (initial value) is set in Pr. 77 "Parameter write selection".

| Function | Parameter | | Name | Increments | Initial value | Setting range | Description | Parameter copy | Parameter clear | All Parameter clear | Refer to page | |
|---|--------------------|---------------------|-------------------|-------------------|------------------------------|---------------|---|--|---|---------------------|---------------|---|
| | Related parameters | | | | | | | ✓: enabled —: disabled | | | | |
| Manual torque boost  | | | 0 | ⊙ | Torque boost | 0.1% | 6/4/3/2 * | 0–30% | Set the output voltage at 0Hz as % * Initial values differ according to the inverter capacity: FR-E720S-050 or less, FR-E740-026 or less/ FR-E720S-080 and 110, FR-E740-040 to 095/ FR-E740-120 and 170/ FR-E740-230 and 300 | ✓ | ✓ | ✓ |
| | 46 | Second torque boost | | | 0.1% | 9999 | 0–30% | Set the torque boost when the RT signal is on. | ✓ | ✓ | ✓ | |
| | | | | | | | | 9999 | Without second torque boost | | | |
| Minimum/maximum frequency | 1 | ⊙ | Maximum frequency | 0.01Hz | 120Hz | 0–120Hz | Set the upper limit of the output frequency | ✓ | ✓ | ✓ | 6-50 | |
| | | | 2 | Minimum frequency | 0.01Hz | 0Hz | 0–120Hz | Set the lower limit of the output frequency | ✓ | ✓ | | ✓ |
| | | | | 18 | High speed maximum frequency | 0.01Hz | 120Hz | 120–400Hz | Set when performing operation at 120Hz or more | ✓ | | ✓ |

Tab. 6-1: Parameter overview (1)

| Function | Parameter | Name | Increments | Initial value | Setting range | Description | Parameter copy | Parameter clear | All Parameter clear | Refer to page | |
|---|------------|---|------------------------|---------------|------------------|---|---------------------------------|-----------------|---------------------|---------------|---|
| | | | | | | | ✓: enabled —: disabled | | | | |
| Base frequency, voltage  | 3 | ⊙ Base frequency | 0.01Hz | 50Hz | 0–400Hz | Set the frequency when the motor rated torque is generated. (50Hz/60Hz) | ✓ | ✓ | ✓ | 6-54 | |
| | | 19 | Base frequency voltage | 0.1V | 8888 | 0–1000V | Maximum inverter output voltage | ✓ | ✓ | | ✓ |
| | | | | | | 8888 | 95% of power supply voltage | | | | |
| | 47 | Second V/f (base frequency) | 0.01Hz | 9999 | 0–400Hz | Set the base frequency when the RT signal is on. | ✓ | ✓ | ✓ | | |
| | | | | | 9999 | Second V/f is invalid. | | | | | |
| Multi-speed setting operation | 4 | ⊙ Multi-speed setting (high speed) | 0.01Hz | 50Hz | 0–400Hz | Set frequency when the RH signal is on. | ✓ | ✓ | ✓ | 6-58 | |
| | 5 | ⊙ Multi-speed setting (middle speed) | 0.01Hz | 30Hz | 0–400Hz | Set frequency when the RM signal is on. | ✓ | ✓ | ✓ | | |
| | 6 | ⊙ Multi-speed setting (low speed) | 0.01Hz | 10Hz | 0–400Hz | Set frequency when the RL signal is on. | ✓ | ✓ | ✓ | | |
| | 24 27 | Multi-speed setting 4 speed to 7 speed | 0.01Hz | 9999 | 0–400Hz/ 9999 | Frequency from 4 speed to 15 speed can be set according to the combination of the RH, RM, RL and REX signals. 9999: not selected | ✓ | ✓ | ✓ | | |
| | 232 239 | Multi-speed setting 8 speed to 15 speed | 0.01Hz | 9999 | 0–400Hz/ 9999 | | | | | | |

Tab. 6-1: Parameter overview (2)

| Function | Parameter | | Increments | Initial value | Setting range | Description | Para- meter copy | Para- meter clear | All Para- meter clear | Refer to page | |
|---|-----------------------|--|--|---------------|--|--|---|-------------------------|--------------------------------|---------------------|------|
| | Related parameters | Name | | | | | ✓: enabled —: disabled | | | | |
| Acceleration/deceleration time setting | 7 | ☉ | Acceleration time | 0.1/ 0.01s | 5/10/ 15s * | 0–3600/ 360s | Set the motor acceleration time * Initial values differ according to the inverter capacity: FR-E720S-110 or less, FR-E740-095 or less/ FR-E740-120 and 170/ FR-E740-230 and 300 | ✓ | ✓ | ✓ | 6-69 |
| | 8 | ☉ | Deceleration time | 0.1/ 0.01s | 5/10/ 15s * | 0–3600/ 360s | Set the motor deceleration time * Initial values differ according to the inverter capacity: FR-E720S-110 or less, FR-E740-095 or less/ FR-E740-120 and 170/ FR-E740-230 and 300 | ✓ | ✓ | ✓ | |
| | 20 | | Acceleration/ deceleration reference frequency | 0.01Hz | 50Hz | 1–400Hz | Set the frequency referenced as acceleration/deceleration time. As acceleration/deceleration time, set the frequency change time from stop to Pr. 20. | ✓ | ✓ | ✓ | |
| | 21 | | Acceleration/ deceleration time increments | 1 | 0 | 0 | Increments: 0.1s Range: 0–3600s Increments and setting range of acceleration/ deceleration time setting can be changed. | ✓ | ✓ | ✓ | |
| | | | | | | 1 | | | | | |
| | 44 | | Second acceleration/ deceleration time | 0.1/ 0.01s | 5/10/ 15s * | 0–3600/ 360s | Set the acceleration/deceleration time when the RT signal is on. * Initial values differ according to the inverter capacity: FR-E720S-110 or less, FR-E740-095 or less/ FR-E740-120 and 170/ FR-E740-230 and 300 | ✓ | ✓ | ✓ | |
| | 45 | | Second deceleration time | 0.1/ 0.01s | 9999 | 0–3600/ 360s | Set the deceleration time when the RT signal is on. Acceleration time = deceleration time | ✓ | ✓ | ✓ | |
| 9999 | | | | | | | | | | | |
| 147 | | Acceleration/decelera- tion time switching frequency | 0.01Hz | 9999 | 0–400Hz/ 9999 | Frequency when automatically switching to the acceleration/ deceleration time of Pr. 44 and Pr. 45. | ✓ | ✓ | ✓ | | |
| Motor protection from overheat (electronic thermal relay function) | 9 | ☉ | Electronic thermal O/L relay | 0.01A | Rated inverter output current * | 0–500A | Set the rated motor current. * The initial value of the 026 or less is set to 85% of the rated inverter current. | ✓ | ✓ | ✓ | 6-80 |
| | | | | | | 0–500A | | | | | |
| | 51 | Second electronic thermal O/L relay | 0.01A | 9999 | 9999 | Second electronic thermal O/L relay invalid | ✓ | ✓ | ✓ | | |

Tab. 6-1: Parameter overview (3)

| Function | Parameter | | Increments | Initial value | Setting range | Description | Parameter copy | Parameter clear | All Parameter clear | Refer to page |
|--|--------------------------------------|--|------------|---------------|---|---|----------------|-----------------|---------------------|---------------|
| | Name | Related parameters | | | | | | | | |
| DC injection brake | 10 | DC injection brake operation frequency | 0.01Hz | 3Hz | 0–120Hz | Set the operation frequency of the DC injection brake. | ✓ | ✓ | ✓ | 6-98 |
| | 11 | DC injection brake operation time | 0.1s | 0.5s | 0 | DC injection brake disabled | ✓ | ✓ | ✓ | |
| | | | | | 0.1–10s | Set the operation time of the DC injection brake. | | | | |
| 12 | DC injection brake operation voltage | 0.1% | 6/4/2 % * | 0.1–30% | DC injection brake disabled Set the DC injection brake voltage (torque). * Initial values differ according to the inverter capacity: FR-E720S-008 and 015/ FR-E720S-030 to 110, FR-E740-016 to 170/ FR-E740-230 and 300 | ✓ | ✓ | ✓ | | |
| Starting frequency | 13 | Starting frequency | 0.01Hz | 0.5Hz | 0–60Hz | Starting frequency can be set. | ✓ | ✓ | ✓ | 6-73 |
| | 571 | Holding time at a start | 0.1s | 9999 | 0.0–10.0s | Set the holding time of Pr. 13 "Starting frequency". | ✓ | ✓ | ✓ | |
| 9999 | | | | | Holding function at start is invalid. | | | | | |
| V/f pattern matching applications  | 14 | Load pattern selection | 1 | 1 | 0 | For constant torque load | ✓ | ✓ | ✓ | 6-56 |
| | | | | | 1 | For variable-torque load | | | | |
| | | | | | 2 | For constant torque elevators | | | | |
| 3 | at forward rotation boost of 0% | | | | | | | | | |
| Jog operation | 15 | Jog frequency | 0.01Hz | 5Hz | 0–400Hz | Set the frequency for jog operation. | ✓ | ✓ | ✓ | 6-61 |
| | 16 | Jog acceleration/ deceleration time | 0.1/ 0.01s | 0.5s | 0–3600/ 360s | Set the acceleration/deceleration time for jog operation. Set the time taken to reach the frequency set in Pr. 20 "Acceleration/deceleration reference frequency" for acceleration/deceleration time (initial value is 50Hz). In addition, acceleration/deceleration time can not be set separately. | ✓ | ✓ | ✓ | |
| MRS input selection | 17 | MRS input selection | 1 | 0 | 0 | Open input always | ✓ | ✓ | ✓ | 6-117 |
| | | | | | 2 | Normally closed input (NC contact input specifications) | | | | |
| | | | | | 4 | External terminal: Normally closed input (NC contact input specifications) Communication: Normally open input | | | | |
| — | 18 | Refer to Pr. 1 and Pr. 2 | | | | | | | | |
| | 19 | Refer to Pr. 3 | | | | | | | | |
| | 20 21 | Refer to Pr. 7 and Pr. 8 | | | | | | | | |

Tab. 6-1: Parameter overview (4)

| Function | Parameter | | Increments | Initial value | Setting range | Description | Parameter copy | Parameter clear | All Parameter clear | Refer to page |
|---------------------------------------|---|--|------------|---------------|--|--|---------------------------|---------------------------|---------------------------|---------------|
| | Related parameters | Name | | | | | ✓: enabled —: disabled | ✓: enabled —: disabled | ✓: enabled —: disabled | |
| Stall prevention operation | 22 | Stall prevention operation level | 0.1% | 150% | 0 | Stall prevention operation selection becomes invalid. | ✓ | ✓ | ✓ | 6-42 |
| | | | | | 0.1–200% | The stall prevention operation level can be set. | | | | |
| | 23 | Stall prevention operation level compensation factor at double speed | 0.1% | 9999 | 0–200% | The stall operation level can be reduced when operating at a high speed above the rated frequency. | ✓ | ✓ | ✓ | |
| | | | | | 9999 | Constant according to Pr. 22 | | | | |
| | 48 | Second stall prevention operation current | 0.1% | 110% | 0 | Second stall prevention operation invalid | ✓ | ✓ | ✓ | |
| | | | | | 0.1–120% | The stall prevention operation level can be set. | | | | |
| | | | | | 9999 | Same level as Pr. 22. | | | | |
| | 66 | Stall prevention operation reduction starting frequency | 0.01Hz | 50Hz | 0–400Hz | Set the frequency at which the stall operation level is started to reduce. | ✓ | ✓ | ✓ | |
| | 156 | Stall prevention operation selection | 1 | 0 | 0–31/100/101 | Pr. 156 allows you to select whether to use stall prevention or not according to the acceleration/deceleration status. | ✓ | ✓ | ✓ | |
| | 157 | OL signal output timer | 0.1s | 0s | 0–25s | Set the output start time of the OL signal output when stall prevention is activated. | ✓ | ✓ | ✓ | |
| 9999 | | | | | Without the OL signal output | | | | | |
| 277 | Stall prevention operation current switchover | 1 | 0 | 0 | When the output current exceeds the limit level, output frequency is limited to limit current. The inverter rated current is the reference to the limit level. | ✓ | ✓ | ✓ | | |
| | | | | 1 | When the output torque exceeds the limit level, output frequency is limited to limit current. The rated motor torque is the reference to the limit level. | | | | | |
| — | 24–27 | Refer to Pr. 4 to Pr. 6 | | | | | | | | |
| Acceleration/ deceleration pattern | 29 | Acceleration/deceleration pattern selection | 1 | 0 | 0 | Linear acceleration/deceleration | ✓ | ✓ | ✓ | 6-75 |
| | | | | | 1 | S-pattern acceleration/deceleration A | | | | |
| | | | | | 2 | S-pattern acceleration/deceleration B | | | | |
| Selection of regeneration unit | 30 | Regenerative function selection | 1 | 0 | 0 | Brake resistor MRS, brake unit FR-BU2, high power factor converter FR-HC, power regeneration common converter FR-CV | ✓ | ✓ | ✓ | 6-101 |
| | | | | | 1 | High-duty brake resistor FR-ABR | | | | |
| | | | | | 2 | High power factor converter FR-HC (when an automatic restart after instantaneous power failure is selected) | | | | |
| | 70 | Special regenerative brake duty | 0.1% | 0% | 0–30% | Set this parameter when a high duty brake resistor or power regeneration converter is used. | ✓ | ✓ | ✓ | |

Tab. 6-1: Parameter overview (5)

| Function | Parameter | Name | Increments | Initial value | Setting range | Description | Parameter copy | Parameter clear | All Parameter clear | Refer to page |
|--|-----------|---|------------|---------------|------------------------|--|---------------------------|-----------------|---------------------|---------------|
| | | | | | | | ✓: enabled —: disabled | | | |
| Avoid mechanical resonance points | 31 | Frequency jump 1A | 0.01Hz | 9999 | 0-400Hz/ 9999 | 1A to 1B, 2A to 2B, 3A to 3B are frequency jumps 9999: Function invalid | ✓ | ✓ | ✓ | 6-52 |
| | 32 | Frequency jump 1B | 0.01Hz | 9999 | 0-400Hz/ 9999 | | ✓ | ✓ | ✓ | |
| | 33 | Frequency jump 2A | 0.01Hz | 9999 | 0-400Hz/ 9999 | | ✓ | ✓ | ✓ | |
| | 34 | Frequency jump 2B | 0.01Hz | 9999 | 0-400Hz/ 9999 | | ✓ | ✓ | ✓ | |
| | 35 | Frequency jump 3A | 0.01Hz | 9999 | 0-400Hz/ 9999 | | ✓ | ✓ | ✓ | |
| | 36 | Frequency jump 3B | 0.01Hz | 9999 | 0-400Hz/ 9999 | | ✓ | ✓ | ✓ | |
| Speed display and speed setting | 37 | Speed display | 0.001 | 0 | 0 | Frequency display, setting | ✓ | ✓ | ✓ | 6-136 |
| | | | | | 0.01-9998 | Set the machine speed at 60Hz. | | | | |
| RUN key rotation direction selection | 40 | RUN key rotation direction selection | 1 | 0 | 0 | Forward rotation | ✓ | ✓ | ✓ | 6-306 |
| | | | | | 1 | Reverse rotation | | | | |
| Detection of output frequency (SU, FU) | 41 | Up-to-frequency sensitivity (SU output) | 0.1% | 10% | 0-100% | Set the level where the SU signal turns on. | ✓ | ✓ | ✓ | 6-129 |
| | 42 | Output frequency detection (FU output) | 0.01Hz | 6Hz | 0-400Hz | Set the frequency where the FU signal turns on. | ✓ | ✓ | ✓ | |
| | 43 | Output frequency detection for reverse rotation | 0.01Hz | 9999 | 0-400Hz | Set the frequency where the FU signal turns on in reverse rotation. | ✓ | ✓ | ✓ | |
| 9999 | | | | | Same as Pr. 42 setting | | | | | |
| — | 44 45 | Refer to Pr. 7 and Pr. 8 | | | | | | | | |
| | 46 | Refer to Pr. 0 | | | | | | | | |
| | 47 | Refer to Pr. 3 | | | | | | | | |
| | 48 | Refer to Pr. 22 | | | | | | | | |
| — | 51 | Refer to Pr. 9 | | | | | | | | |

Tab. 6-1: Parameter overview (6)

| Function | Parameter | Name | Increments | Initial value | Setting range | Description | Parameter copy | Parameter clear | All Parameter clear | Refer to page |
|-------------------|------------------------------------|-------------------------------------|------------|---------------|--|--|---------------------------|-----------------|---------------------|---------------|
| | | | | | | | ✓: enabled —: disabled | | | |
| Display functions | 52 | DU/PU main display data selection | 1 | 0 | 0/5/7-12/ 14/20/ 23-25/ 52-57/61/ 62/100 | Selects monitor to be displayed on the operation panel and parameter unit and monitor to be output to the terminal AM. 0: Output frequency (Pr. 52) 1: Output frequency (Pr. 158) 2: Output current (Pr. 158) 3: Output voltage (Pr. 158) 5: Frequency setting value 7: Motor torque 8: Converter output voltage 9: Regenerative brake duty 10: Electronic thermal relay function load factor 11: Output current peak value 12: Converter output voltage peak value 14: Output power 20: Cumulative energization time (Pr. 52) 21: Reference voltage output (Pr. 158) 23: Actual operation time (Pr. 52) 24: Motor load factor 25: Cumulative power (Pr. 52) 52: PID set point 53: PID measured value 54: PID deviation (Pr. 52) 55: I/O terminal status (Pr. 52) 56: Option input terminal status (Pr. 52) 57: Option output terminal status (Pr. 52) 61: Motor thermal load factor 62: Inverter load factor 100: Set frequency is displayed during a stop and output frequency is displayed during operation (Pr. 52). | ✓ | ✓ | ✓ | 6-138 |
| | 158 | AM terminal function selection | 1 | 1 | 1-3/5/7-12/ 14/21/24/ 52/53/61/62 | | ✓ | ✓ | ✓ | |
| | 170 | Watt-hour meter clear | 1 | 9999 | 0 | Set "0" to clear the watt-hour meter monitor. | ✓ | — | ✓ | |
| | | | | | 10 | Set the maximum value when monitoring from communication to 0 to 9999kWh. | | | | |
| | | | | | 9999 | Set the maximum value when monitoring from communication to 0 to 65535kWh. | | | | |
| | 171 | Operation hour meter clear | 1 | 9999 | 0/9999 | Set "0" in the parameter to clear the watt hour monitor. Setting "9999" has no effect. | ✓ | ✓ | ✓ | |
| | 268 | Monitor decimal digits selection | 1 | 9999 | 0 | Displays the monitor as integral value. | ✓ | — | ✓ | |
| | | | | | 1 | Displays the monitor in increments of 0.1. | | | | |
| | | | | | 9999 | No fixed decimal position | | | | |
| | 563 | Energizing time carrying-over times | 1 | 0 | 0-65535 | The numbers of cumulative energizing time monitor exceeded 65535h is displayed. Reading only | — | — | — | |
| 564 | Operating time carrying-over times | 1 | 0 | 0-65535 | The numbers of operation time monitor exceeded 65535h is displayed. Reading only | — | — | — | | |

Tab. 6-1: Parameter overview (7)

| Function | Parameter | Name | Increments | Initial value | Setting range | Description | Parameter copy | Parameter clear | All Parameter clear | Refer to page | |
|---|--------------------------------|---|------------|-------------------------------|---|---|---------------------------|-----------------|---------------------|---------------|--|
| | | | | | | | ✓: enabled —: disabled | | | | |
| Change of the monitor output from terminal AM | 55 | Frequency monitoring reference | 0.01Hz | 50Hz | 0–400Hz | Set the full-scale value to output the output frequency monitor value to terminal AM. | ✓ | ✓ | ✓ | 6-146 | |
| | 56 | Current monitoring reference | 0.01 | Rated inverter output current | 0–500 | Set the full-scale value to output the output current monitor value to terminal AM. | ✓ | — | ✓ | | |
| Restart operation after instantaneous power failure | 57 | Restart coasting time | 0.1s | 9999 | 0 | The coasting time is as follows: FR-E720S-080 or less, FR-E740-040 or less: 1 s, FR-E720S-110, FR-E740-060 to 170: 2 s, FR-E740-230 and 300: 3 s | ✓ | ✓ | ✓ | 6-151 | |
| | | | | | 0.1–5s | Set the waiting time for inverter-triggered restart after an instantaneous power failure. | | | | | |
| | | | | | 9999 | No restart | | | | | |
| | 58 | Restart cushion time | 0,1 s | 1 s | 0–60 s | Set a voltage starting time at restart. | ✓ | ✓ | ✓ | | |
| | 162 | Automatic restart after instantaneous power failure selection | 1 | 1 | 0 | With frequency search | ✓ | ✓ | ✓ | | |
| | | | | | 1 | Without frequency search (Reduced voltage system) | | | | | When using the frequency search, consider the wiring length limit. (Refer to page 3-12.) |
| | | | | | 10 | Frequency search at every start | | | | | |
| | | | | | 11 | Reduced voltage system at every start | | | | | |
| | 165 | Stall prevention operation level for restart | 0.1% | 150% | 0–200% | Consider the rated inverter current as 100% and set the stall prevention operation level during restart operation. | ✓ | ✓ | ✓ | | |
| | 298 | Frequency search gain | 1 | 9999 | 0–32767 | When offline auto tuning is performed under V/f control, frequency search gain necessary for frequency search for automatic restart after instantaneous power failure is set as well as the motor constants (R1). | ✓ | — | ✓ | | |
| | | | | | 9999 | Uses the Mitsubishi motor (SF-JR, SF-HRCA) constants | | | | | |
| | 299 | Rotation direction detection selection at restarting | 1 | 9999 | 0 | Without rotation direction detection | ✓ | ✓ | ✓ | | |
| | | | | | 1 | With rotation direction detection | | | | | |
| 9999 | | | | | When Pr. 78 = "0", the rotation direction is detected. When Pr. 78 = "1", "2", the rotation direction is not detected. | | | | | | |
| 611 | Acceleration time at a restart | 0.1s | 9999 | 0–3600s | Set the acceleration time to reach the set frequency at a restart. | ✓ | ✓ | ✓ | | | |
| | | | | 9999 | Acceleration time for restart is the normal acceleration time (e.g. Pr. 7). | | | | | | |

Tab. 6-1: Parameter overview (8)

| Function | Parameter | Name | Increments | Initial value | Setting range | Description | Parameter copy | Parameter clear | All Parameter clear | Refer to page | | |
|---|--|-------------------------------------|------------|---------------|--|---|------------------------------------|-----------------|---------------------|---------------|---------------|---|
| | | | | | | | ✓: enabled —: disabled | | | | | |
| Remote setting function | 59 | Remote function selection | 1 | 0 | 0 | RH, RM, RL signal function | Frequency setting storage function | ✓ | ✓ | ✓ | 6-65 | |
| | | | | | | Multi-speed setting | — | | | | | |
| | | | | | | 1 | Remote setting | | | | | Yes |
| | | | | | | 2 | Remote setting | | | | | No |
| | | | | | | 3 | Remote setting | | | | | No (Turning STF/STR off clears remote setting frequency.) |
| Energy saving control selection  | 60 | Energy saving control selection | 1 | 0 | 0 | Normal operation mode | ✓ | ✓ | ✓ | 6-171 | | |
| | | | | | 9 | Optimum excitation control mode (OEC) | | | | | | |
| Automatic acceleration/deceleration | 61 | Reference current | 0.01A | 9999 | 0–500A | Setting value (rated motor current) is referenced | ✓ | ✓ | ✓ | 6-77 | | |
| | | | | | 9999 | Rated inverter current is referenced | | | | | | |
| | 62 | Reference value at acceleration | 1% | 9999 | 0–200% | Setting value is a limit value | ✓ | ✓ | ✓ | | | |
| | | | | | 9999 | 150% is a limit value | | | | | | |
| | 63 | Reference value at deceleration | 1% | 9999 | 0–200% | Setting value is a limit value | ✓ | ✓ | ✓ | | | |
| | | | | | 9999 | 150% is a limit value | | | | | | |
| | 292 | Automatic acceleration/deceleration | 1 | 0 | 0 | Normal mode | ✓ | ✓ | ✓ | | | |
| | | | | | 1 | Shortest acceleration/deceleration mode | | | | | Without brake | |
| | | | | | 11 | Shortest acceleration/deceleration mode | | | | | With brake | |
| | | | | | 7 | Brake sequence mode 1 | | | | | | |
| 8 | Brake sequence mode 2 | | | | | | | | | | | |
| 293 | Acceleration/deceleration separate selection | 1 | 0 | 0 | Calculates acceleration/deceleration time of both acceleration and deceleration for the shortest acceleration/deceleration mode. | ✓ | ✓ | ✓ | | | | |
| | | | | 1 | Calculates only acceleration time for the shortest acceleration/deceleration mode. | | | | | | | |
| | | | | 2 | Calculates only deceleration time for the shortest acceleration/deceleration mode. | | | | | | | |

Tab. 6-1: Parameter overview (9)

| Function | Parameter | Name | Increments | Initial value | Setting range | Description | Parameter copy | Parameter clear | All Parameter clear | Refer to page |
|------------------------------------|---------------------------|---------------------------------------|------------|---------------|--|--|---------------------------|-----------------|---------------------|---------------|
| | | | | | | | ✓: enabled —: disabled | | | |
| Retry function at alarm occurrence | 65 | Retry selection | 1 | 0 | 0–5 | An alarm for retry can be selected. | ✓ | ✓ | ✓ | 6-166 |
| | 67 | Number of retries at alarm occurrence | 1 | 0 | 0 | No retry function | ✓ | ✓ | ✓ | |
| | | | | | 1–10 | Set the number of retries at alarm occurrence. An alarm output is not provided during retry operation. | | | | |
| | | | | | 101–110 | Set the number of retries at alarm occurrence. (The setting value minus 100 is the number of retries.) An alarm output is provided during retry operation. | | | | |
| | 68 | Retry waiting time | 0.1s | 1s | 0.1–360s | Set the waiting time from when an inverter alarm occurs until a retry is made. | ✓ | ✓ | ✓ | |
| 69 | Retry count display erase | 1 | 0 | 0 | Clear the number of restarts succeeded by retry. | ✓ | ✓ | ✓ | | |
| — | 66 | Refer to Pr. 22 and Pr. 23 | | | | | | | | |
| — | 67 – 69 | Refer to Pr. 65 | | | | | | | | |
| — | 70 | Refer to Pr. 30 | | | | | | | | |

Tab. 6-1: Parameter overview (10)

| Function | Parameter | Name | Increments | Initial value | Setting range | Description | Parameter copy | Parameter clear | All Parameter clear | Refer to page | |
|---------------|---|---|------------|---------------|---------------|---|---------------------------|-----------------|---------------------|---------------|---|
| | | | | | | | ✓: enabled —: disabled | | | | |
| Applied motor | 71 | Applied motor | 1 | 0 | 0 | Thermal characteristics of a standard motor | ✓ | ✓ | ✓ | 6-85 | |
| | | | | | 1 | Thermal characteristics of the Mitsubishi constant-torque motor | | | | | |
| | | | | | 40 | Thermal characteristic of Mitsubishi high efficiency standard motor (SF-HR) | | | | | |
| | | | | | 50 | Thermal characteristic of Mitsubishi constant torque motor (SF-HRCA) | | | | | |
| | | | | | 3 | Standard motor | | | | | Select "offline auto tuning setting" |
| | | | | | 13 | Constant-torque motor | | | | | |
| | | | | | 23 | Mitsubishi standard motor SF-JR 4P (≤ 1,5 kW) | | | | | |
| | | | | | 43 | Mitsubishi high efficiency motor (SF-HR) | | | | | |
| | | | | | 53 | Mitsubishi constant-torque motor (SF-HRCA) | | | | | |
| | | | | | 4 | Standard motor | | | | | Auto tuning data can be read, changed, and set. |
| | | | | | 14 | Constant-torque motor | | | | | |
| | | | | | 24 | Mitsubishi standard motor SF-JR 4P (≤ 1,5 kW) | | | | | |
| | | | | | 44 | Mitsubishi high efficiency motor (SF-HR) | | | | | |
| | | | | | 54 | Mitsubishi constant-torque motor (SF-HRCA) | | | | | |
| | | | | | 5 | Standard motor | | | | | Star connection Direct input of motor constants is enabled |
| | | | | | 15 | Constant-torque motor | | | | | |
| | | | | | 6 | Standard motor | | | | | Delta connection Direct input of motor constants is enabled |
| | | | | | 16 | Constant-torque motor | | | | | |
| | | | | | 450 | Second applied motor | | | | | 1 |
| | 1 | Thermal characteristics of the Mitsubishi constant-torque motor | | | | | | | | | |
| 9999 | Second motor is invalid (thermal characteristic of the first motor (Pr.71)) | | | | | | | | | | |

Tab. 6-1: Parameter overview (11)

| Function | Parameter | Name | Increments | Initial value | Setting range | Description | Parameter copy | Parameter clear | All Parameter clear | Refer to page | |
|---|----------------------------|---|------------------------------|---------------|----------------------------|--|--|-----------------|---------------------|---------------|-------|
| | | | | | | | ✓: enabled —: disabled | | | | |
| Carrier frequency and Soft-PWM selection | 72 | PWM frequency selection | 1 | 1 | 0–15 | PWM carrier frequency can be changed. The setting displayed is in [kHz]. Note that 0 indicates 0.7kHz, 15 indicates 14.5kHz. | ✓ | ✓ | ✓ | 6-172 | |
| | | 240 | Soft-PWM operation selection | 1 | 1 | 0 1 | Soft-PWM invalid When Pr. 72 = "0 to 5", Soft-PWM is valid. | ✓ | ✓ | | ✓ |
| Analog input selection | 73 | Analog input selection | 1 | 1 | 0 | Terminal 2 input 0–10V | Polarity reversible | ✓ | — | ✓ | 6-174 |
| | | | | | 1 | 0–5V | | | | | |
| | | | | | 10 | 0–10V | With | | | | |
| | | | | | 11 | 0–5V | | | | | |
| 267 | Terminal 4 input selection | 1 | 0 | 0 | Terminal 4 input 4 to 20mA | ✓ | — | ✓ | | | |
| | | | | 1 | Terminal 4 input 0 to 5V | | | | | | |
| | | | | 2 | Terminal 4 input 0 to 10V | | | | | | |
| Noise elimination at the analog input | 74 | Input filter time constant | 1 | 1 | 0–8 | The primary delay filter time constant for the analog input can be set. A larger setting results in a larger filter. | ✓ | ✓ | ✓ | 6-179 | |
| Reset selection/disconnected PU/PU stop | 75 | Reset selection/disconnected PU/PU stop | 1 | 14 | 0–3/14–17 | You can select the reset input acceptance, disconnected PU (operation panel/FR-PU04/FR-PU07) connector detection function and PU stop function. For the initial value, reset always enabled, without disconnected PU detection, and with PU stop function are set. | ✓ | — | — | 6-187 | |
| Prevention of parameter rewrite | 77 | Parameter write selection | 1 | 0 | 0 | Write is enabled only during a stop | ✓ | ✓ | ✓ | 6-192 | |
| | | | | | 1 | Parameter write is disabled. | | | | | |
| | | | | | 2 | Parameter write is enabled in any operation mode regardless of operation status. <i>Note:</i> <i>Parameters that can generally be written during operation should not be written as well with this setting.</i> | | | | | |
| Prevention of reverse rotation of the motor | 78 | Reverse rotation prevention selection | 1 | 0 | 0 | Both forward and reverse rotations allowed | ✓ | ✓ | ✓ | 6-194 | |
| | | | | | 1 | Reverse rotation disallowed | | | | | |
| | | | | | 2 | Forward rotation disallowed | | | | | |

Tab. 6-1: Parameter overview (12)

| Function | Parameter | | Increments | Initial value | Setting range | Description | Parameter copy | Parameter clear | All Parameter clear | Refer to page | |
|-----------------------------|--------------------|--|------------|---------------|----------------|---|----------------|-----------------|---------------------|---------------|---|
| | Related parameters | Name | | | | | | | | | ✓: enabled —: disabled |
| Operation mode selection | 79 | ⊙ | 1 | 0 | 0 | External/PU switch over mode | ✓ | ✓ | ✓ | 6-198 | |
| | | | | | 1 | Fixed to PU operation mode | | | | | |
| | | | | | 2 | Fixed to External operation mode | | | | | |
| | | | | | 3 | External/PU combined operation mode 1 | | | | | |
| | | | | | 4 | External/PU combined operation mode 2 | | | | | |
| | | | | | 6 | Switch-over mode | | | | | |
| | | | | | 7 | External operation mode (PU operation interlock) | | | | | |
| | 340 | | 1 | 0 | 0 | As set in Pr. 79. | ✓ | ✓ ^① | ✓ ^① | 6-210 | |
| | | | | | 1 | Started in the network operation mode. | | | | | |
| | | | | | 10 | Started in the network operation mode. Operation mode can be changed between the PU operation mode and network operation mode from the operation panel. | | | | | |
| Selection of control method | 80 | | 0.01kW | 9999 | 0.1–15kW | Set the applied motor capacity. | ✓ | ✓ | ✓ | 6-36 | |
| | | | | | 9999 | V/f control is performed | | | | | |
| | 81 | | 1 | 9999 | 2/4/6/8/10 | Set the number of motor poles. | ✓ | ✓ | ✓ | | |
| | | | | | 12/14/16/18/20 | X18 signal ON: V/f control | | | | | Set 10 + number of motor poles |
| | | | | | 9999 | V/f control is performed | | | | | |
| | 89 | Speed control gain (advanced magnetic flux vector) | 0.1% | 9999 | 0–200% | Motor speed fluctuation due to load fluctuation is adjusted during advanced magnetic flux vector control. 100% is a referenced value. | ✓ | — | ✓ | | |
| | | | | | 9999 | Gain matching with the motor set in Pr. 71. | | | | | |
| | 800 | Control method selection | 1 | 20 | 20 | Advanced magnetic flux vector control | ✓ | ✓ | ✓ | | |
| | | | | | 30 | General-purpose magnetic flux vector control | | | | | Set a value other than "9999" in Pr. 80 and Pr. 81. |

Tab. 6-1: Parameter overview (13)

① These parameters are communication parameters that are not cleared when parameter clear (all clear) is executed from RS-485 communication. (Refer to section 6.19 for RS-485 communication) Note that when using a three-phase power input specification model, Pr. 345 and Pr. 346 are set back to initial values.

| Function | Parameter Related parameters | Name | Increments | Initial value | Setting range | Description | Parameter copy | Parameter clear | All Parameter clear | Refer to page |
|---------------------|---------------------------------|--------------------------|------------|---------------|---------------|---|---------------------------|-----------------|---------------------|---------------|
| | | | | | | | ✓: enabled —: disabled | | | |
| Offline auto tuning | 82 | Motor excitation current | 0.01A * | 9999 | 0–500A * | Tuning data (The value measured by offline auto tuning is automatically set.) * The range differs according to the Pr. 71 setting. | ✓ | — | ✓ | 6-88 |
| | | | | | 9999 | Uses the Mitsubishi motor (SF-JR, SF-HRCA) constants | | | | |
| | 83 | Motor rated voltage | 0.1V | 200V/400V * | 0–1000V | Set the rated motor voltage (V). * The initial value differs according to the voltage class: 200V/400V | ✓ | ✓ | ✓ | |
| | 84 | Rated motor frequency | 0.01Hz | 50Hz | 10–120Hz | Set the rated motor frequency (Hz). | ✓ | ✓ | ✓ | |
| | 90 | Motor constant (R1) | 0.001Ω* | 9999 | 0–50Ω * | Tuning data (The value measured by offline auto tuning is automatically set.) * The range differs according to the Pr. 71 setting. | ✓ | — | ✓ | |
| | | | | | 9999 | Use constants of the Mitsubishi motor (SF-JR, SF-HR, SF-JRCA, SF-HRCA) | | | | |
| | 91 | Motor constant (R2) | 0.001Ω* | 9999 | 0–50Ω * | Tuning data (The value measured by offline auto tuning is automatically set.) * The range differs according to the Pr. 71 setting. | ✓ | — | ✓ | |
| | | | | | 9999 | Use constants of the Mitsubishi motor (SF-JR, SF-HR, SF-JRCA, SF-HRCA) | | | | |
| | 92 | Motor constant (L1) | 0.1mH * | 9999 | 0–1000mH * | Tuning data (The value measured by offline auto tuning is automatically set.) * The range differs according to the Pr. 71 setting. | ✓ | — | ✓ | |
| | | | | | 9999 | Use constants of the Mitsubishi motor (SF-JR, SF-HR, SF-JRCA, SF-HRCA) | | | | |
| | 93 | Motor constant (L2) | 0.1mH * | 9999 | 0–1000mH * | Tuning data (The value measured by offline auto tuning is automatically set.) * The range differs according to the Pr. 71 setting. | ✓ | — | ✓ | |
| | | | | | 9999 | Use constants of the Mitsubishi motor (SF-JR, SF-HR, SF-JRCA, SF-HRCA) | | | | |

Tab. 6-1: Parameter overview (14)

| Function | Parameter | Name | Increments | Initial value | Setting range | Description | Parameter copy | Parameter clear | All Parameter clear | Refer to page | | |
|---------------------|-----------|----------------------------|-----------------------|---------------|---------------|---|---------------------------|-----------------|---------------------|---------------|--|--|
| | | | | | | | ✓: enabled —: disabled | | | | | |
| Offline auto tuning | 94 | Motor constant (X) | 0.1% * | 9999 | 0–100% * | Tuning data (The value measured by offline auto tuning is automatically set.) * The range differs according to the Pr. 71 setting. | ✓ | — | ✓ | 6-88 | | |
| | | | | | 9999 | Use the Mitsubishi motor (SF-JR, SF-HRCA) constants | | | | | | |
| | 96 | Auto tuning setting/status | 1 | 0 | 0 | Offline auto tuning is not performed | ✓ | — | ✓ | | | |
| | | | | | 1 | For advanced magnetic flux vector control Offline auto tuning is performed without motor running (all motor constants) | | | | | | |
| | | | | | 11 | For general-purpose magnetic flux vector control Offline auto tuning is performed without motor running (motor constant (R1) only) | | | | | | |
| | | | | | 21 | Offline auto tuning for V/F control (automatic restart after instantaneous power failure (with frequency search)) | | | | | | |
| | 859 | Torque current | 0.01A * | 9999 | 0–500A * | Tuning data (The value measured by offline auto tuning is automatically set.) * The range differs according to the Pr. 71 setting. | ✓ | — | ✓ | | | |
| | | | | | 9999 | Use the Mitsubishi motor (SF-JR, SF-HRCA) constants | | | | | | |
| | — | 89 | Refer to Pr. 81 | | | | | | | | | |
| | | 90 | Refer to Pr. 82 to 84 | | | | | | | | | |
| 94 | | | | | | | | | | | | |
| 96 | | Refer to Pr. 82 to 84 | | | | | | | | | | |

Tab. 6-1: Parameter overview (15)

| Function | Parameter Related parameters | Name | Increments | Initial value | Setting range | Description | Parameter copy | Parameter clear | All Parameter clear | Refer to page |
|-------------------------------|---------------------------------------|--------------------------------------|------------|---------------|--|--|---------------------------|-----------------|---------------------|---------------|
| | | | | | | | ✓: enabled —: disabled | | | |
| Communication initial setting | 117 | PU communication station | 1 | 0 | 0-31 (0-247) | Set the inverter station numbers when two or more inverters are connected to one personal computer. When "1" (Modbus-RTU protocol) is set in Pr. 549, the setting range within parenthesis is applied. | ✓ | ✓ ^① | ✓ ^① | 6-226 |
| | 118 | PU communication speed | 1 | 192 | 48/96/ 192/384 | Set the communication speed. The setting value × 100 equals the communication speed. For example, the communication speed is 19200bps when the setting value is "192". | ✓ | ✓ ^① | ✓ ^① | |
| | 119 | PU communication stop bit length | 1 | 1 | 0 | Stop bit length: 1bit data length: 8bit | ✓ | ✓ ^① | ✓ ^① | |
| | | | | | 1 | Stop bit length: 2bit data length: 8bit | | | | |
| | | | | | 10 | Stop bit length: 1bit data length: 7bit | | | | |
| | | | | | 11 | Stop bit length: 2bit data length: 7bit | | | | |
| | 120 | PU communication parity check | 1 | 2 | 0 | Without parity check (for Modbus-RTU: stop bit length: 2bit) | ✓ | ✓ ^① | ✓ ^① | |
| | | | | | 1 | With odd parity check (for Modbus-RTU: stop bit length: 1bit) | | | | |
| | | | | | 2 | With even parity check (for Modbus-RTU: stop bit length: 1bit) | | | | |
| | 121 | Number of PU communication retries | 1 | 1 | 0-10 | If the number of consecutive errors exceeds the permissible value, E.PUE (computer link)/ E.ESR (Modbus-RTU) will cause an alarm stop. | ✓ | ✓ ^① | ✓ ^① | |
| | | | | | 9999 | If a communication error occurs, the inverter will not come to an alarm stop. | | | | |
| | 122 | PU communication check time interval | 0.1s | 9999 | 0 | No PU connector communication | ✓ | ✓ ^① | ✓ ^① | |
| | | | | | 0.1-999.8s | Set the communication check time interval. If a no-communication state persists for longer than the permissible time, the inverter will come to an alarm stop. | | | | |
| 9999 | | | | | No communication check | | | | | |
| 123 | PU communication waiting time setting | 1 | 9999 | 0-150ms | Set the waiting time between data transmission to the inverter and response. | ✓ | ✓ ^① | ✓ ^① | | |
| | | | | 9999 | Set with communication data. | | | | | |

Tab. 6-1: Parameter overview (16)

① These parameters are communication parameters that are not cleared when parameter clear (all clear) is executed from RS-485 communication. (Refer to section 6.19 for RS-485 communication) Note that when using a three-phase power input specification model, Pr. 345 and Pr. 346 are set back to initial values.

| Function | Parameter | Name | Increments | Initial value | Setting range | Description | Parameter copy | Parameter clear | All Parameter clear | Refer to page |
|-------------------------------|-----------|---|------------|---------------|---------------|---|---------------------------|-----------------|---------------------|---------------|
| | | | | | | | ✓: enabled —: disabled | | | |
| Communication initial setting | 124 | PU communication CR/LF presence/absence selection | 1 | 1 | 0 | Without CR/LF | ✓ | ✓ ^① | ✓ ^① | 6-226 |
| | | | | | 1 | With CR | | | | |
| | | | | | 2 | With CR/LF | | | | |
| | 342 | Communication E ² PROM write selection | 1 | 0 | 0 | Parameter values written by communication are written to the E ² PROM and RAM. | ✓ | ✓ | ✓ | |
| | | | | | 1 | Parameter values written by communication are written to the RAM. | | | | |
| | 343 | Communication error count | 1 | 0 | Read only | Display the number of communication errors during Modbus-RTU communication. Read only. Displayed only when Modbus-RTU protocol is selected. | — | — | — | |
| | 502 | Stop mode selection at communication error | 1 | 0 | 0/3 | You can select the inverter operation if a communication error occurs. | ✓ | ✓ | ✓ | |
| | | | | | 1/2 | | | | | |
| | 549 | Protocol selection | 1 | 0 | 0 | Mitsubishi inverter (computer link) protocol | ✓ | ✓ ^① | ✓ ^① | |
| | | | | | 1 | Modbus-RTU protocol | | | | |

Tab. 6-1: Parameter overview (17)

- ① These parameters are communication parameters that are not cleared when parameter clear (all clear) is executed from RS-485 communication. (Refer to section 6.19 for RS-485 communication) Note that when using a three-phase power input specification model, Pr. 345 and Pr. 346 are set back to initial values.

| Function | Parameter | Name | Increments | Initial value | Setting range | Description | Para- meter copy | Para- meter clear | All Para- meter clear | Refer to page | |
|---|-----------------------------------|---|---|---------------|---|---|---|-------------------------|--------------------------------|---------------------|-------|
| | | | | | | | ✓: enabled —: disabled | | | | |
| Change of analog input frequency, adjustment of voltage, current input and frequency (calibration) | 125 | ☉ | Terminal 2 frequency setting gain frequency | 0.01Hz | 50Hz | 0–400Hz | Set the frequency of terminal 2 input gain (maximum). | ✓ | — | ✓ | 6-180 |
| | 126 | ☉ | Terminal 4 frequency setting gain frequency | 0.01Hz | 50Hz | 0–400Hz | Set the frequency of terminal 4 input gain (maximum). | ✓ | — | ✓ | |
| | 241 | Analog input display unit switch over | 1 | 0 | 0 | Select the unit for analog input display. | ✓ | ✓ | ✓ | | |
| | | | | | 1 | | Displayed in V/mA | ✓ | ✓ | ✓ | |
| | C2 (902) | Terminal 2 frequency setting bias frequency | 0.01Hz | 0Hz | 0–400Hz | Set the frequency on the bias side of terminal 2 input. | ✓ | — | ✓ | | |
| | C3 (902) | Terminal 2 frequency setting bias | 0.1% | 0% | 0–300% | Set the converted % of the bias side voltage (current) of terminal 2 input. | ✓ | — | ✓ | | |
| | C4 (903) | Terminal 2 frequency setting gain | 0.1% | 100% | 0–300% | Set the converted % of the gain side voltage of terminal 2 input. | ✓ | — | ✓ | | |
| | C5 (904) | Terminal 4 frequency setting bias frequency | 0.01Hz | 0Hz | 0–400Hz | Set the frequency on the bias side of terminal 4 input. | ✓ | — | ✓ | | |
| | C6 (904) | Terminal 4 frequency setting bias | 0.1% | 20% | 0–300% | Set the converted % of the bias side current (voltage) of terminal 4 input. | ✓ | — | ✓ | | |
| C7 (905) | Terminal 4 frequency setting gain | 0.1% | 100% | 0–300% | Set the converted % of the gain side current (voltage) of terminal 4 input. | ✓ | — | ✓ | | | |

Tab. 6-1: Parameter overview (18)

| Function | Parameter Related parameters | Name | Increments | Initial value | Setting range | Description | Parameter copy | Parameter clear | All Parameter clear | Refer to page | |
|-------------|---------------------------------|--|------------|---------------|--|---|---------------------------|-----------------|---------------------|---------------|--|
| | | | | | | | ✓: enabled —: disabled | | | | |
| PID control | 127 | PID control automatic switchover frequency | 0.01Hz | 9999 | 0–400Hz | Set the frequency at which the control is automatically changed to PID control. | ✓ | ✓ | ✓ | 6-270 | |
| | | | | | 9999 | Without PID automatic switchover function | | | | | |
| | 128 | PID action selection | 1 | 0 | 0 | PID control invalid | ✓ | ✓ | ✓ | | |
| | | | | | 20 | PID reverse action | | | | | Measured value input (terminal 4) Set value (terminal 2 or Pr. 133) |
| | | | | | 21 | PID forward action | | | | | |
| | | | | | 40–43 | Dancer control | | | | | |
| | | | | | 50 | PID reverse action | | | | | Deviation value signal input (CC-Link communication) |
| | | | | | 51 | PID forward action | | | | | |
| | | | | | 60 | PID reverse action | | | | | Measured value and set point input (CC-Link communication) |
| | 61 | PID forward action | | | | | | | | | |
| | 129 | PID proportional band | 0.1% | 100% | 0.1–1000% | If the proportional band is narrow (parameter setting is small), the manipulated variable varies greatly with a slight change of the measured value. Hence, as the proportional band narrows, the response sensitivity (gain) improves but the stability deteriorates, e.g. hunting occurs. Gain $K_p = 1/\text{proportional band}$ | ✓ | ✓ | ✓ | | |
| | | | | | 9999 | No proportional control. | | | | | |
| | 130 | PID integral time | 0.1 s | 1s | 0.1–3600s | Time required for only the integral (I) action to provide the same manipulated variable as that for the proportional (P) action. As the integral time decreases, the set point is reached earlier but hunting occurs more easily. | ✓ | ✓ | ✓ | | |
| | | | | | 9999 | No integral control. | | | | | |
| | 131 | PID upper limit | 0.1% | 9999 | 0–100% | Set the upper limit value. If the feedback value exceeds the setting, the FUP signal is output. The maximum input (20mA/5V/10V) of the measured value (terminal 4) is equivalent to 100%. | ✓ | ✓ | ✓ | | |
| | | | | | 9999 | No function | | | | | |
| | 132 | PID lower limit | 0.1% | 9999 | 0–100% | Set the lower limit value. If the process value falls below the setting range, the FDN signal is output. The maximum input (20mA/5V/10V) of the measured value (terminal 4) is equivalent to 100% | ✓ | ✓ | ✓ | | |
| | | | | | 9999 | No function | | | | | |
| | 133 | PID action set point | 0.01% | 9999 | 0–100% | Used to set the set point for PID control in the PU operation mode. | ✓ | ✓ | ✓ | | |
| 9999 | | | | | No function | | | | | | |
| 134 | PID differential time | 0.01s | 9999 | 0.01–10.00s | Time required for only the differential (D) action to provide the same manipulated variable as that for the proportional (P) action. As the differential time increases, greater response is made to a deviation change. | ✓ | ✓ | ✓ | | | |
| | | | | 9999 | No differential control. | | | | | | |

Tab. 6-1: Parameter overview (19)

| Function | Parameter | Name | Increments | Initial value | Setting range | Description | Parameter copy | Parameter clear | All Parameter clear | Refer to page |
|---|------------------|---|------------|---------------|---|---|---------------------------|-----------------|---------------------|---------------|
| | | | | | | | ✓: enabled —: disabled | | | |
| Parameter unit language switchover | 145 | PU display language selection | 1 | 1 | 0 | Japanese | ✓ | — | — | 6-306 |
| | | | | | 1 | English | | | | |
| | | | | | 2 | German | | | | |
| | | | | | 3 | French | | | | |
| | | | | | 4 | Spanish | | | | |
| | | | | | 5 | Italian | | | | |
| | | | | | 6 | Swedish | | | | |
| | | | | | 7 | Finnish | | | | |
| — | 146 | Parameter for manufacturer setting. Do not set. | | | | | | | | |
| — | 147 | Refer to Pr. 7 and Pr. 8 | | | | | | | | |
| Detection of output current (Y12 signal) and Detection of zero current (Y13 signal) | 150 | Output current detection level | 0.1% | 150% | 0–200% | Set the output current detection level. 100% is the rated inverter current. | ✓ | ✓ | ✓ | 6-131 |
| | 151 | Output current detection signal delay time | 0.1s | 0s | 0–10s | Set the output current detection period. Set the time from when the output current has risen above the setting until the output current detection signal (Y12) is output. | ✓ | ✓ | ✓ | |
| | 152 | Zero current detection level | 0.1% | 5% | 0–200% | Set the zero current detection level. Suppose that the rated inverter current at the specified overload capacity is 100%. | ✓ | ✓ | ✓ | |
| | 153 | Zero current detection time | 0.01s | 0.5s | 0–1s | Set this parameter to define the period from when the output current drops below the Pr. 152 value until the zero current detection signal (Y13) is output. | ✓ | ✓ | ✓ | |
| — | 156 157 | Refer to Pr. 22 | | | | | | | | |
| — | 158 | Refer to Pr. 52 | | | | | | | | |
| User group function | 160 | ⊙ User group read selection | 1 | 0 | 0 | Simple mode and extended mode parameters can be displayed. | ✓ | ✓ | ✓ | 6-195 |
| | | | | | 1 | Only parameters registered in the user group can be displayed. | | | | |
| | | | | | 9999 | Only the simple mode parameters can be displayed | | | | |
| | 172 | User group registered display/batch clear | 1 | 0 | (0–16) | Displays the number of cases registered as a user group (reading only). | ✓ | — | — | |
| | | | | | 9999 | Batch clear the user group registration | | | | |
| | 173 | User group registration | 1 | 9999 | 0–999/9999 | Set the parameter numbers to be registered to the user group. Read value is always "9999". | — | — | — | |
| 174 | User group clear | 1 | 9999 | 0–999/9999 | Set the parameter numbers to be cleared from the user group. Read value is always "9999". | — | — | — | | |



Tab. 6-1: Parameter overview (20)

| Function | Parameter | Name | Increments | Initial value | Setting range | Description | Parameter copy | Parameter clear | All Parameter clear | Refer to page | |
|--|-----------------|---|------------|---------------|---|--|---------------------------|-----------------|---------------------|---------------|-------|
| | | | | | | | ✓: enabled —: disabled | | | | |
| Operation selection of the operation panel | 161 | Frequency setting/key lock operation selection | 1 | 0 | 0 | Setting dial frequency setting mode | Key lock mode invalid | ✓ | — | ✓ | 6-307 |
| | | | | | 1 | Setting dial potentiometer mode | | | | | |
| | | | | | 10 | Setting dial frequency setting mode | Key lock mode valid | | | | |
| | | | | | 11 | Setting dial potentiometer mode | | | | | |
| — | 162 165 | Refer to Pr. 57 | | | | | | | | | |
| | 168 169 | Parameter for manufacturer setting. Do not set. | | | | | | | | | |
| | 170 171 | Refer to Pr. 52 | | | | | | | | | |
| | 172 — 174 | Refer to Pr. 160 | | | | | | | | | |
| Function assignment of input terminal | 178 | STF terminal function selection | 1 | 60 | 0-5/7/8/10/ 12/14-16/ 18/24/25/ 60/62/ 65-67/9999 | 0: Low-speed operation command 1: Middle-speed operation command 2: High-speed operation command | ✓ | — | ✓ | 6-114 | |
| | 179 | STR terminal function selection | 1 | 61 | 0-5/7/8/10/ 12/14-16/ 18/24/25/ 61/62/ 65-67/9999 | 3: Second function selection 4: Terminal 4 input selection 5: Jog operation selection 7: External thermal relay input 8: Fifteen speed selection | ✓ | — | ✓ | | |
| | 180 | RL terminal function selection | 1 | 0 | 0-5/7/8/10/ 12/14-16/ 18/24/25/ 62/65-67/ 9999 | 10: Inverter operation enable signal (FR-HC/FR-CV connection) 12: PU operation external interlock | ✓ | — | ✓ | | |
| | 181 | RM terminal function selection | 1 | 1 | | 14: PID control valid terminal 15: Brake opening completion signal | ✓ | — | ✓ | | |
| | 182 | RH terminal function selection | 1 | 2 | | 16: PU-external operation switchover 18: V/f switchover | ✓ | — | ✓ | | |
| | 183 | MRS terminal function selection | 1 | 3 | | 24: Output stop 25: Start self-holding selection | ✓ | — | ✓ | | |
| | 184 | RES terminal function selection | 1 | 4 | | 60: Forward rotation command (assigned to STF terminal (Pr. 178) only) 61: Reverse rotation command (assigned to STR terminal (Pr. 179) only) 62: Inverter reset 65: NET/PU operation switchover 66: External/NET operation switchover 67: Command source switchover 9999: No function | ✓ | — | ✓ | | |

Tab. 6-1: Parameter overview (21)

| Function | Parameter | Name | Increments | Initial value | Setting range | Description | Parameter copy | Parameter clear | All Parameter clear | Refer to page |
|--|-----------|---------------------------------|------------|---------------|---|---|---------------------------|-----------------|---------------------|---------------|
| | | | | | | | ✓: enabled —: disabled | | | |
| Function assignment of output terminal | 190 | RUN terminal function selection | 1 | 0 | 0/1/3/4/7/8/ 11-16/20/ 25/26/46/ 47/64/90/ 91/93/95/ 96/98/99/ 100/101/ 103/104/ 107/108/ 111-116/ 120/125/ 126/146/ 147/164/ 190/191/ 193/195/ 196/198/ 199/9999 | 0/100: Inverter running 1/101: Up to frequencych 3/103: Overload alarm 4/104: Output frequency detection 7/107: Regenerative brake prealarm 8/108: Electronic thermal relay function prealarm | ✓ | — | ✓ | 6-124 |
| | 191 | FU terminal function selection | 1 | 1 | | 11/111: Inverter operation ready 12/112: Output current detection 13/113: Zero current detection 14/114: PID lower limit 15/115: PID upper limit 16/116: PID forward/reverse rotation output | ✓ | — | ✓ | |
| | 192 | ABC terminal function selection | 1 | 2 | | 20/120: Brake opening request 25/125: Fan fault output 26/126: Heatsink overheat prealarm 46/146: During deceleration at occurrence of power failure (retained until release) 47/147: PID control activated 64/164: During retry 90/190: Life alarm 91/191: Alarm output 3 (power-off signal) 93/193: Current average monitor 95/195: Maintenance timer alarm 96/196: Remote output 98/198: Minor fault output 99/199: Alarm output 9999: No function 0-99: Source logic 100-199: Sink logic | ✓ | — | ✓ | |
| — | 232-239 | Refer to Pr. 4 to Pr. 6 | | | | | | | | |
| | 240 | Refer to Pr. 72 | | | | | | | | |
| | 241 | Refer to Pr. 125 and Pr. 126 | | | | | | | | |

Tab. 6-1: Parameter overview (22)

| Function | Parameter | Name | Increments | Initial value | Setting range | Description | Parameter copy | Parameter clear | All Parameter clear | Refer to page |
|---|---|---|------------|---------------|---------------|--|---------------------------|-----------------|---------------------|---------------|
| | | | | | | | ✓: enabled —: disabled | | | |
| Increase cooling fan life | 244 | Cooling fan operation selection | 1 | 1 | 0 | Operates at power on Cooling fan on/off control invalid (The cooling fan is always on at power on.) | ✓ | ✓ | ✓ | 6-295 |
| | | | | | 1 | Cooling fan on/off control valid | | | | |
| Slip compensation   | 245 | Rated slip | 0.01% | 9999 | 0–50% | Used to set the rated motor slip. | ✓ | ✓ | ✓ | 6-41 |
| | | | | | 9999 | No slip compensation | | | | |
| | 246 | Slip compensation time constant | 0.01s | 0.5s | 0.01–10s | Used to set the response time of slip compensation. When the value is made smaller, response will be faster. However, as load inertia is greater, a regenerative over voltage (E.OV□) error is more liable to occur. | ✓ | ✓ | ✓ | |
| | | | | | | 247 | | | | |
| 9999 | Slip compensation is made in the constant output range. | | | | | | | | | |
| Ground fault detection | 249 | Earth (ground) fault detection at start | 1 | 0 | 0 | Without ground fault detection | ✓ | ✓ | ✓ | 6-170 |
| | | | | | 1 | With ground fault detection | | | | |
| Selection of motor stopping method | 250 | Stop selection | 0.1s | 9999 | 0–100s | The motor is coasted to a stop when the preset time elapses after the start signal is turned off. STF signal: Forward rotation start STR signal: Reverse rotation start | ✓ | ✓ | ✓ | 6-103 |
| | | | | | 1000–1100s | The motor is coasted to a stop (Pr. 250 – 1000)s after the start signal is turned off. STF signal: Start signal STR signal: Forward/reverse signal | | | | |
| | | | | | 8888 | When the start signal is turned off, the motor decelerates to stop. STF signal: Start signal STR signal: Forward/reverse signal | | | | |
| | | | | | 9999 | | | | | |

Tab. 6-1: Parameter overview (23)

| Function | Parameter | Name | Increments | Initial value | Setting range | Description | Parameter copy | Parameter clear | All Parameter clear | Refer to page |
|---|-----------|---|------------|---------------|---------------|--|---------------------------|-----------------|---------------------|---------------|
| | | | | | | | ✓: enabled —: disabled | | | |
| Input/output phase failure protection selection | 251 | Output phase failure protection selection | 1 | 1 | 0 | Without output phase failure protection | ✓ | ✓ | ✓ | 6-169 |
| | | | | | 1 | With output phase failure protection | | | | |
| | 872 | Input phase failure protection selection | 1 | 1 | 0 | Without input phase failure protection | ✓ | ✓ | ✓ | |
| | | | | | 1 | With input phase failure protection | | | | |
| Display of the life of the inverter parts | 255 | Life alarm status display | 1 | 0 | (0-15) | Display whether the control circuit capacitor, main circuit capacitor, cooling fan, and each parts of the inrush current limit circuit has reached the life alarm output level or not. (Reading only) | — | — | — | 6-296 |
| | 256 | Inrush current limit circuit life display | 1% | 100% | (0-100%) | Display the deterioration degree of the inrush current limit circuit. (Reading only) | — | — | — | |
| | 257 | Control circuit capacitor life display | 1% | 100% | (0-100%) | Display the deterioration degree of the control circuit capacitor. (Reading only) | — | — | — | |
| | 258 | Main circuit capacitor life display | 1% | 100% | (0-100%) | Display the deterioration degree of the main circuit capacitor. (Reading only) The value measured by Pr. 259 is displayed. | — | — | — | |
| | 259 | Main circuit capacitor life measuring | 1 | 0 | 0/1 | Setting "1" and switching the power supply off starts the measurement of the main circuit capacitor life. When the Pr. 259 value is "3" after powering on again, the measuring is completed. Displays the deterioration degree in Pr. 258. | ✓ | ✓ | ✓ | |
| Operation at instantaneous power failure | 261 | Power failure stop selection | 1 | 0 | 0 | Coasting to stop When under voltage or power failure occurs, the inverter output is shut off. | ✓ | ✓ | ✓ | 6-162 |
| | | | | | 1 | When under voltage or a power failure occurs, the inverter can be decelerated to a stop. | | | | |
| | | | | | 2 | When under voltage or a power failure occurs, the inverter can be decelerated to a stop. If power is restored during a power failure, the inverter accelerates again. | | | | |
| — | 267 | Refer to Pr. 73 | | | | | | | | |
| | 268 | Refer to Pr. 52 | | | | | | | | |
| | 269 | Parameter for manufacturer setting: Do not set. | | | | | | | | |

Tab. 6-1: Parameter overview (24)

| Function | Parameter Related parameters | Name | Increments | Initial value | Setting range | Description | Parameter copy | Parameter clear | All Parameter clear | Refer to page | | | | | |
|--|---------------------------------|---|------------|---------------|--|--|---------------------------|-----------------|---------------------|---------------|--------------------------------------|------|------|--------|---|
| | | | | | | | ✓: enabled —: disabled | | | | | | | | |
| Stop-on contact control AD MFVC GP MFVC | 270 | Stop-on contact control selection | 1 | 0 | 0 | Without stop-on contact control | ✓ | ✓ | ✓ | 6-105 | | | | | |
| | | | | | 1 | Stop-on contact control | | | | | | | | | |
| | 275 | Stop-on contact excitation current low-speed multiplying factor | 0,1 % | 9999 | 0–300 % | Usually set a value between 130% and 180%. Set the force (holding torque) for stop-on contact control. | ✓ | ✓ | ✓ | | | | | | |
| | | | | | 9999 | No compensation. | | | | | | | | | |
| | 276 | PWM carrier frequency at stop-on contact | 1 | 9999 | 0–9 | Set a PWM carrier frequency for stop-on contact control. (Valid at the output frequency of 3Hz or less.) | ✓ | ✓ | ✓ | | | | | | |
| | | | | | 9999 | As set in Pr. 72 "PWM frequency selection". | | | | | | | | | |
| — | 277 | Refer to Pr. 22 | | | | | | | | | | | | | |
| Brake sequence function AD MFVC GP MFVC | 278 | Brake opening frequency | 0.01Hz | 3Hz | 0–30Hz | Set to the rated slip frequency of the motor + about 1.0Hz. This parameter may be set only if Pr. 278 ≤ Pr. 282. | ✓ | ✓ | ✓ | 6-109 | | | | | |
| | | | | | | 279 | | | | | Brake opening current | 0.1% | 130% | 0–200% | Generally, set this parameter to about 50 to 90%. If the setting is too low, the load is liable to drop due to gravity at start. Suppose that the rated inverter current is 100%. |
| | | | | | | 280 | | | | | Brake opening current detection time | 0.1s | 0.3s | 0–2s | Generally, set this parameter to about 0.1 to 0.3s. |
| | | | | | | 281 | | | | | Brake operation time at start | 0.1s | 0.3s | 0–5s | Pr. 292 = 7: Set the mechanical delay time until the brake is loosened. Pr. 292 = 8: Set the mechanical delay time until the brake is loosened + about 0.1 to 0.2s. |
| | | | | | | | | | | | | | | | 282 |
| | | | | | | 283 | | | | | Brake operation time at stop | 0.1s | 0.3s | 0–5s | Pr. 292 = 7: Set the mechanical delay time until the brake is closed + 0.1s. Pr. 292 = 8: Set the mechanical delay time until the brake is closed + about 0.2 to 0.3 seconds. |
| | 292 | Automatic acceleration/deceleration | 1 | 0 | 0/1/7/8/11 | Brake sequence function is made valid when a setting is "7 or 8". | | | | | | | | | |
| Droop control AD MFVC | 286 | Droop gain | 0.1% | 0% | 0 | Droop control is invalid | ✓ | ✓ | ✓ | 6-291 | | | | | |
| | | | | | 0.1–100% | Set the drooping amount at the rated torque as a percentage with respect to the rated motor frequency. | | | | | | | | | |
| 287 | Droop filter time constant | 0.01s | 0.3s | 0–1s | Set the time constant of the primary delay filter applied to the torque current. | ✓ | ✓ | ✓ | | | | | | | |

Tab. 6-1: Parameter overview (25)

| Function | Parameter | | Name | Increments | Initial value | Setting range | Description | Parameter copy | Parameter clear | All Parameter clear | Refer to page |
|--|--------------------|---------------------------|---|------------|---------------|---------------------|---|----------------|-----------------|---------------------|---------------|
| | Related parameters | ✓: enabled —: disabled | | | | | | | | | |
| — | 292 293 | | Refer to Pr. 61 | | | | | | | | |
| Setting of the magnitude of frequency change by the setting dial | 295 | | Magnitude of frequency change setting | 0,01 | 0 | 0 | Invalid | ✓ | ✓ | ✓ | 6-308 |
| | | | | | | 0/0.01/ 0.1/1/10 | The setting increments when the set frequency is changed by the setting dial can be set. | | | | |
| — | 298 299 | | Refer to Pr. 57 | | | | | | | | |
| Communication | 338 | | Communication operation command source | 1 | 0 | 0 | Operation command source communication | ✓ | ✓ ^① | ✓ ^① | 6-212 |
| | | | | | | 1 | Operation command source external (start/stop) | | | | |
| | 339 | | Communication speed command source | 1 | 0 | 0 | Speed command source communication | ✓ | ✓ ^① | ✓ ^① | |
| | | | | | | 1 | Speed command source external (Frequency setting from communication is invalid, terminal 2 setting from external is valid) | | | | |
| | | | | | | 2 | Speed command source external (Frequency setting from communication is valid, terminal 2 setting from external is invalid) | | | | |
| | 550 | | NET mode operation command source selection | 1 | 9999 | 0 | Communication option valid | ✓ | ✓ ^① | ✓ ^① | |
| | | | | | | 2 | PU connector valid | | | | |
| | 551 | | PU mode operation command source selection | 1 | 9999 | 9999 | Automatic recognition of the communication option Normally, PU connector is valid. Communication option is valid when the communication option is mounted. | ✓ | ✓ ^① | ✓ ^① | |
| | | | | | | 2 | Selects the PU connector as the PU operation mode control source | | | | |
| | | | | | | 3 | Selects the USB connector as the PU operation mode control source. | | | | |
| | | | | | | 4 | Selects the operation panel as the PU operation mode control source. | | | | |
| | | 9999 | USB connection, PU07 connection automatic recognition Priorities: USB > PU07 > operation panel | | | | | | | | |
| — | 340 | | Refer to Pr. 79 | | | | | | | | |
| | 342 343 | | Refer to Pr. 117 to Pr. 124 | | | | | | | | |
| | 450 | | Refer to Pr. 71 | | | | | | | | |

Tab. 6-1: Parameter overview (26)

① These parameters are communication parameters that are not cleared when parameter clear (all clear) is executed from RS-485 communication. (Refer to section 6.19 for RS-485 communication) Note that when using a three-phase power input specification model, Pr. 345 and Pr. 346 are set back to initial values.

| Function | Parameter | Name | Increments | Initial value | Setting range | Description | Para- meter copy | Para- meter clear | All Para- meter clear | Refer to page |
|--|------------|---|------------|---------------|---------------|--|---------------------------|-------------------------|--------------------------------|---------------------|
| | | | | | | | ✓: enabled —: disabled | | | |
| Remote output function (REM signal) | 495 | Remote output selection | 1 | 0 | 0 | Remote output data clear at powering off | ✓ | ✓ | ✓ | 6-133 |
| | | | | | 1 | Remote output data retention at powering off | | | | |
| | | | | | 10 | Remote output data clear at powering off | | | | |
| | | | | | 11 | Remote output data retention at powering off | | | | |
| | 496 | Remote output data 1 | 1 | 0 | 0-4095 | Output terminal can be switched on and off. | | — | — | — |
| | 497 | Remote output data 2 | 1 | 0 | 0-4095 | — | — | — | | |
| — | 502 | Refer to Pr. 124 | | | | | | | | |
| Maintenance of parts | 503 | Maintenance timer | 1 | 0 | 0 (1-9998) | Display the cumulative energizing time of the inverter in 100h increments. Reading only Writing the setting of "0" clears the cumulative energizing time. | — | — | — | 6-300 |
| | 504 | Maintenance timer alarm output set time | 1 | 9999 | 0-9998 | Set the time taken until when the maintenance timer alarm output signal (Y95) is output. | ✓ | — | ✓ | |
| 9999 | | | | | No function | | | | | |
| Inverter setup using USB communication | 547 | USB communication station number | 1 | 0 | 0-31 | Specifies the inverter station number. | ✓ | ✓ ^① | ✓ ^① | 6-269 |
| | 548 | USB communication check time interval | 0.1 s | 9999 | 0 | USB communication is enabled. However, the inverter will come to an alarm stop (E.USB) if operation is changed to PU operation mode. | ✓ | ✓ ^① | ✓ ^① | |
| | | | | | 0.1-999.8s | Set the interval of communication check time. | | | | |
| | 551 | Refer to Pr. 338 to Pr. 339 | | | | | | | | |
| — | 549 | Refer to Pr. 117 to Pr. 124 | | | | | | | | |
| | 550 551 | Refer to Pr. 338 and Pr. 339 | | | | | | | | |

Tab. 6-1: Parameter overview (27)

- ① These parameters are communication parameters that are not cleared when parameter clear (all clear) is executed from RS-485 communication. (Refer to section 6.19 for RS-485 communication) Note that when using a three-phase power input specification model, Pr. 345 and Pr. 346 are set back to initial values.

| Function | Parameter | Name | Increments | Initial value | Setting range | Description | Parameter copy | Parameter clear | All Parameter clear | Refer to page |
|---------------------------------|------------|---|------------|------------------------|---------------|--|---|-----------------|---------------------|---------------|
| | | | | | | | ✓: enabled —: disabled | | | |
| Current average monitor signal | 555 | Current average time | 0.1s | 1s | 0.1–1.0s | Set the time taken to average the current during start bit output (1s). | ✓ | ✓ | ✓ | 6-301 |
| | 556 | Data output mask time | 0.1s | 0s | 0.0–20.0s | Set the time for not obtaining (mask) transient state data. | ✓ | ✓ | ✓ | |
| | 557 | Current average value monitor signal output reference current | 0.01A | Rated inverter current | 0–500A | Set the reference (100%) for outputting the signal of the current average value | ✓ | ✓ | ✓ | |
| — | 563 564 | Refer to Pr. 52 | | | | | | | | |
| | 571 | Refer to Pr. 13 | | | | | | | | |
| | 611 | Refer to Pr. 57 | | | | | | | | |
| Reduce mechanical resonance | 653 | Speed smoothing control | 0.1% | 0 | 0–200% | The torque fluctuation is reduced to reduce vibration due to mechanical resonance. | ✓ | ✓ | ✓ | 6-173 |
| — | 665 | Refer to Pr. 882 | | | | | | | | |
| | 800 | Refer to Pr. 80 | | | | | | | | |
| | 859 | Refer to Pr. 84 | | | | | | | | |
| | 872 | Refer to Pr. 251 | | | | | | | | |
| | 645 | Refer to Pr. C1 (901) | | | | | | | | |
| Regeneration avoidance function | 882 | Regeneration avoidance operation selection | 1 | 0 | 0 | Regeneration avoidance function invalid | ✓ | ✓ | ✓ | 6-292 |
| | | | | | 1 | Regeneration avoidance function is always valid | | | | |
| | | | | | 2 | Regeneration avoidance function is valid only during a constant speed operation | | | | |
| | 883 | Regeneration avoidance operation level | 0.1V | 400V/ 780V * | 300–800V | Set the bus voltage level at which regeneration avoidance operates. When the bus voltage level is set to low, overvoltage error will be less apt to occur. However, the actual deceleration time increases. The set value must be higher than the "power supply voltage × √2". * The initial value differs according to the voltage class: 200V/400V | ✓ | ✓ | ✓ | |
| | | | | | | 885 | Regeneration avoidance compensation frequency limit value | 0.01Hz | 6Hz | |
| | 886 | Regeneration avoidance voltage gain | 0.1% | 100% | 0–200% | Adjusts responsiveness at activation of regeneration avoidance. A larger setting of Pr. 886 will improve responsiveness to the bus voltage change. However, the output frequency could become unstable. | ✓ | ✓ | ✓ | |
| 665 | | | | | | Regeneration avoidance frequency gain | | | | 0.1% |

Tab. 6-1: Parameter overview (28)

| Function | Parameter Related parameters | Name | Increments | Initial value | Setting range | Description | Parameter copy | Parameter clear | All Parameter clear | Refer to page |
|--|---------------------------------|---|------------|---------------|---------------|---|---------------------------|-----------------|---------------------|---------------|
| | | | | | | | ✓: enabled —: disabled | | | |
| Free parameter | 888 | Free parameter 1 | 1 | 9999 | 0–9999 | Parameters you can use for your own purposes. Used for maintenance, management, etc. by setting a unique number to each inverter when multiple inverters are used. Data is held even if the inverter power is turned off. | ✓ | — | — | 6-305 |
| | 889 | Free parameter 2 | 1 | 9999 | 0–9999 | | ✓ | — | — | |
| Adjustment of terminal AM output (calibration) | C1 (901) | AM terminal calibration | — | — | — | Calibrate the scale of the analog meter connected to terminal AM. | ✓ | — | ✓ | 6-148 |
| | 645 | AM 0V adjustment | 1 | 1000 | 970–1200 | Calibrates the scale of the meter when analog output is 0. | ✓ | — | ✓ | |
| — | C2 (902) — C7 (905) | Refer to Pr. 125 and Pr. 126 | | | | | | | | |
| — | C22 (922) — C25 (923) | Parameter for manufacturer setting. Do not set. | | | | | | | | |
| Buzzer control of the operation panel | 990 | PU buzzer control | 1 | 1 | 0 | Without buzzer | ✓ | ✓ | ✓ | 6-309 |
| | | | | | 1 | With buzzer | | | | |
| Contrast adjustment of the parameter unit | 991 | PU contrast adjustment | 1 | 58 | 0–63 | Contrast adjustment of the LCD of the parameter unit (FR-PU04) can be performed. 0 (light) → 63 (dark) | ✓ | ✓ | ✓ | 6-309 |
| Clear parameters, Initial value change list | Pr.CL | Parameter clear | 1 | 0 | 0/1 | Setting "1" returns all parameters except calibration parameters to the initial values. | | | | 4-16 |
| | ALLC | All parameter clear | 1 | 0 | 0/1 | Setting "1" returns all parameters to the initial values. | | | | 4-16 |
| | Er.CL | Fault history clear | 1 | 0 | 0/1 | Setting "1" will clear eight past alarms. | | | | 7-18 |
| | Pr.CH | Initial value change list | 1 | 0 | 0 | Displays the parameters changed from the initial value. | | | | 4-17 |

Tab. 6-1: Parameter overview (29)

NOTE

The parameter number in parentheses is the one for use with the parameter unit (FR-PU04/FR-PU07).

6.2 Control mode

V/f control (initial setting), advanced magnetic flux vector control and general-purpose magnetic flux vector control are available with this inverter.

V/f control

It controls frequency and voltage so that the ratio of frequency (f) to voltage (V) is constant when changing frequency.

Advanced (general-purpose) magnetic flux vector control

- This control divides the inverter output current into an excitation current and a torque current by vector calculation and makes voltage compensation to flow a motor current which meets the load torque. Before operation of a motor in advanced magnetic flux vector control, the self-setting of motor data must occur.
- General-purpose magnetic flux vector control is the same function as the FR-E500 series. For other cases, select advanced magnetic flux vector control.

If the following conditions are not satisfied, select V/f control since malfunction such as insufficient torque and uneven rotation may occur.

- The motor capacity should be equal to or one rank lower than the inverter capacity.
- Motor to be used is any of Mitsubishi standard motor, high efficiency motor (SF-JR, SF-HR 0.2kW or more) or Mitsubishi constant torque motor (SF-JRCA four-pole, SF-HRCA 0.4kW to 15kW). When using a motor other than the above (other manufacturer's motor), perform offline auto tuning without fail.
- Single-motor operation (one motor run by one inverter) should be performed.
- Wiring length from inverter to motor should be within 30m. (Perform offline auto tuning in the state where wiring work is performed when the wiring length exceeds 30m.)

6.2.1 Change the control method (Pr. 80, Pr. 81, Pr. 800)

Set when selecting the control method for advanced magnetic flux vector control and general-purpose magnetic flux vector control. The initial value is V/f control.

- Select a control mode using Pr. 800 "Control method selection".

| Pr. No. | Name | Initial Value | Setting Range | Description | | Parameters referred to | Refer to Section |
|---------|--------------------------|---------------|---------------|---------------------------------|---|------------------------|------------------|
| 80 | Motor capacity | 9999 | 0.1–15kW | Set the applied motor capacity. | | | |
| | | | 9999 | V/f control | | | |
| 81 | Number of motor poles | 9999 | 2/4/6/8/10 | Set the number of motor poles. | | | |
| | | | 9999 | V/f control | | | |
| 800 | Control method selection | 20 | 20 | V/f control | Advanced magnetic flux vector control ^① | | |
| | | | 30 | | General-purpose magnetic flux vector control ^① | | |

| Parameters referred to | Refer to Section |
|--|------------------|
| Advanced magnetic flux vector control | 6.3.2 |
| General-purpose magnetic flux vector control | 6.3.3 |
| 178–184 Input terminal function selection | 6.10.1 |
| 450 Second applied motor | 6.8.2 |
| 44 Second acceleration/deceleration time | 6.7.1 |
| 45 Second deceleration time | 6.7.1 |
| 46 Second torque boost | 6.3.1 |
| 47 Second V/f (base frequency) | 6.5.1 |
| 48 Second stall prevention operation current | 6.3.5 |
| 51 Second electronic thermal O/L relay | 6.8.1 |

① Set a value other than "9999" in Pr. 80 and Pr. 81.

Setting of the motor capacity and the number of motor poles (Pr. 80, Pr. 81)

- Motor specifications (motor capacity and number of motor poles) must be set to select advanced magnetic flux vector control or general-purpose magnetic flux vector control.
- Set the motor capacity (kW) in Pr. 80 "Motor capacity" and set the number of motor poles in Pr. 81 "Number of motor poles".

Selection of control method

Select the inverter control method for V/f control, advanced magnetic flux vector control, and general-purpose magnetic flux vector control.

| Pr. 80, Pr. 81 | Pr. 800 | Control Method |
|--|-------------------------------|--|
| ≠ 9999 | 20 (Pr. 800 initial value) | Advanced magnetic flux vector control |
| | 30 | General-purpose magnetic flux vector control |
| 9999 (Pr. 80, Pr. 81 initial value) | — ^① | V/f control |

Tab. 6-2: Selection of control method

① Control method is V/f control regardless of the setting value of Pr. 800 when "9999" is set in Pr. 80 "Motor capacity" or Pr. 81 "Number of motor poles".

Control method switching by external terminals (X18 signal)

- Use the V/f switchover signal (X18) to change the control method (V/f control-advanced magnetic flux vector control (general-purpose magnetic flux vector control)) with external terminal.
- Turn the X18 signal on to change the currently selected control method (advanced magnetic flux vector control or general-purpose magnetic flux vector control) to V/f control.

For the terminal used for X18 signal input, set "18" in any of Pr. 178 to Pr. 184 "Input terminal function selection" to assign the function.

NOTES

When V/f control is selected by V/f switchover (X18 signal), second function is also selected at the same time. Control between V/f and advanced (general-purpose) magnetic flux can not be switched while the inverter is running. In case control is switched between V/f and advanced (general-purpose) magnetic flux, only second function is selected.

Changing the terminal assignment using Pr. 178 to Pr. 184 "Input terminal function selection" may affect the other functions. Make setting after confirming the function of each terminal.

6.3 Adjust the output torque (current) of the motor

| Purpose | Parameter that must be set | | Refer to Section |
|--|---|--|------------------|
| Set starting torque manually | Manual torque boost | Pr. 0, Pr. 46, | 6.3.1 |
| Automatically control output current according to load | Advanced magnetic flux vector control, general-purpose magnetic flux vector control | Pr. 71, Pr. 80, Pr. 81, Pr. 90, Pr. 450, Pr. 800 | 6.3.2 6.3.3 |
| Compensate for motor slip to secure low-speed torque | Slip compensation (V/f control and general-purpose magnetic flux vector control only) | Pr. 245–Pr. 247 | 6.3.4 |
| Limit output current to prevent inverter trip | Stall prevention operation | Pr. 22, Pr. 23, Pr. 66, Pr. 156, Pr. 157 | 6.3.5 |

6.3.1 Manual torque boost (Pr. 0, Pr. 46)

You can compensate for a voltage drop in the low-frequency region to improve motor torque reduction in the low-speed range.

Motor torque in the low-frequency range can be adjusted to the load to increase the starting motor torque.

Two kinds of start torque boosts can be changed by switching between terminals.

| Pr. No. | Name | Initial Value | | Setting Range | Description | Parameters referred to | Refer to Section |
|-----------|----------------------------------|---|----|---------------|--|--|-----------------------------------|
| 0 | Torque boost | FR-E720S-008 to 050, FR-E740-016 and 026 | 6% | 0–30% | Set the output voltage at 0Hz as %. | 3 Base frequency 19 Base frequency voltage 71 Applied motor 178–184 Input terminal function selection | 6.5.1 6.5.1 6.8.2 6.10.1 |
| | | FR-E720S-080 and 110, FR-E740-040 to 095 | 4% | | | | |
| | | FR-E740-120 and 170 | 3% | | | | |
| | | FR-E740-230 and 300 | 2% | | | | |
| 46 | Second torque boost ^① | 9999 | | 0–30% | Set the torque boost value when the RT signal is on. | | |
| | | | | 9999 | Without second torque boost | | |

① The above parameter can be set when Pr. 160 "User group read selection" = 0.

Starting torque adjustment

On the assumption that Pr. 19 "Base frequency voltage" is 100%, set the output voltage at 0Hz in % to Pr. 0 (Pr. 46).

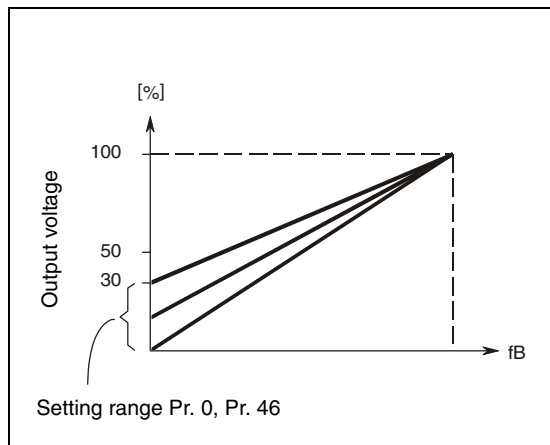
**Fig. 6-1:**

Relationship between output frequency and output voltage

1000001C

**CAUTION:**

Adjust the parameter little by little (about 0.5%), and check the motor status each time. If the setting is too large, the motor will overheat. The guideline is about 10% at the greatest.

The requirements of the motor manufacturer must also be observed.

Set multiple base frequencies (RT signal, Pr. 46)

Use the second torque boost when changing the torque boost according to application or when using multiple motors by switching between them by one inverter.

Pr. 46 "Second torque boost" is made valid when the RT signal turns on. The RT signal acts as the second function selection signal and makes the other second functions valid.

NOTES

The RT signal acts as the second function selection signal and makes the other second functions valid. (Refer to section 6.10.3.)

The amount of current flows in the motor may become large according to the conditions such as the motor characteristics, load, acceleration/deceleration time, wiring length, etc., resulting in an overcurrent trip (OL (overcurrent alarm) then E.OC1 (overcurrent trip during acceleration), overload trip (E.THM (motor overload trip), or E.THT (inverter overload trip). (When a fault occurs, release the start command, and decrease the Pr. 0 setting 1% by 1% to reset.)

The Pr. 0, Pr. 46 settings are valid only when V/f control is selected.

When using the inverter dedicated motor (constant torque motor) with the FR-E740-120 and 170, set torque boost value to 2%. When Pr. 0 = 3% (initial value), if Pr. 71 value is changed to the setting for use with a constant-torque motor, the Pr. 0 setting changes to 2%.

Changing the terminal assignment using Pr. 178 to Pr. 189 "Input terminal function selection" may affect the other functions. Please make setting after confirming the function of each terminal.

6.3.2 Advanced magnetic flux vector control (Pr. 71, Pr. 80, Pr. 81, Pr.89, Pr. 800)

Advanced magnetic flux vector control can be selected by setting the capacity, poles and type of the motor used in Pr. 80 and Pr. 81.

- **Advanced magnetic flux vector control?**
The low speed torque can be improved by providing voltage compensation so that the motor current which meets the load torque to flow. Output frequency compensation (slip compensation) is made so that the motor actual speed approximates a speed command value. Effective when load fluctuates drastically, etc.
When the FR-E500 series used for general-purpose magnetic flux vector control was replaced, select general-purpose magnetic flux vector control only when the same operation characteristic is necessary.

| Pr. No. | Name | Initial Value | Setting Range | Description | Parameters referred to | Refer to Section |
|---------|--|---------------|---------------------------------------|---|------------------------------|------------------|
| 71 | Applied motor | 0 | 0/1/3-6/13-16/23/24/40/43/44/50/53/54 | By selecting a standard motor or constant-torque motor, thermal characteristic and motor constants of each motor are set. | 71 Applied motor | 6.8.2 |
| | | | 450 Second applied motor | 6.8.2 | | |
| 80 | Motor capacity | 9999 | 0.1-15kW | Set the applied motor capacity. | 800 Control method selection | 6.2.1 |
| | | | 9999 | V/f control | | |
| 81 | Number of motor poles | 9999 | 2/4/6/8/10 | Set the number of motor poles. | | |
| | | | 9999 | V/f control | | |
| 89 | Speed control gain (advanced magnetic flux vector) | 9999 | 0-200% | Motor speed fluctuation due to load fluctuation is adjusted during advanced magnetic flux vector control. 100% is a referenced value. | | |
| | | | 9999 | Gain matching with the motor set in Pr. 71. | | |
| 800 | Control method selection | 20 | 20 | Advanced magnetic flux vector control ^① | | |
| | | | 30 | General-purpose magnetic flux vector control ^① | | |

The above parameters can be set when Pr. 160 "User group read selection" = 0.

- ① Set a value other than "9999" in Pr. 80 and Pr. 81.

If the following conditions are not satisfied, select V/f control since malfunction such as insufficient torque and uneven rotation may occur.

- The motor capacity should be equal to or one rank lower than the inverter capacity.
- Motor to be used is any of Mitsubishi standard motor, high efficiency motor (SF-JR, SF-HR 0.2kW or more) or Mitsubishi constant-torque motor (SF-JRCA four-pole, SF-HRCA 0.4kW to 15kW). When using a motor other than the above (other manufacturer's motor), perform offline auto tuning without fail.
- Single-motor operation (one motor run by one inverter) should be performed.
- The wiring length from inverter to motor should be within 30m. (Perform offline auto tuning in the state where wiring work is performed when the wiring length exceeds 30m.)
- Permissible wiring length between inverter and motor differs according to the inverter capacity and setting value of Pr. 72 "PWM frequency selection" (carrier frequency). (Refer to page 3-12).

Selection method of advanced magnetic flux vector control

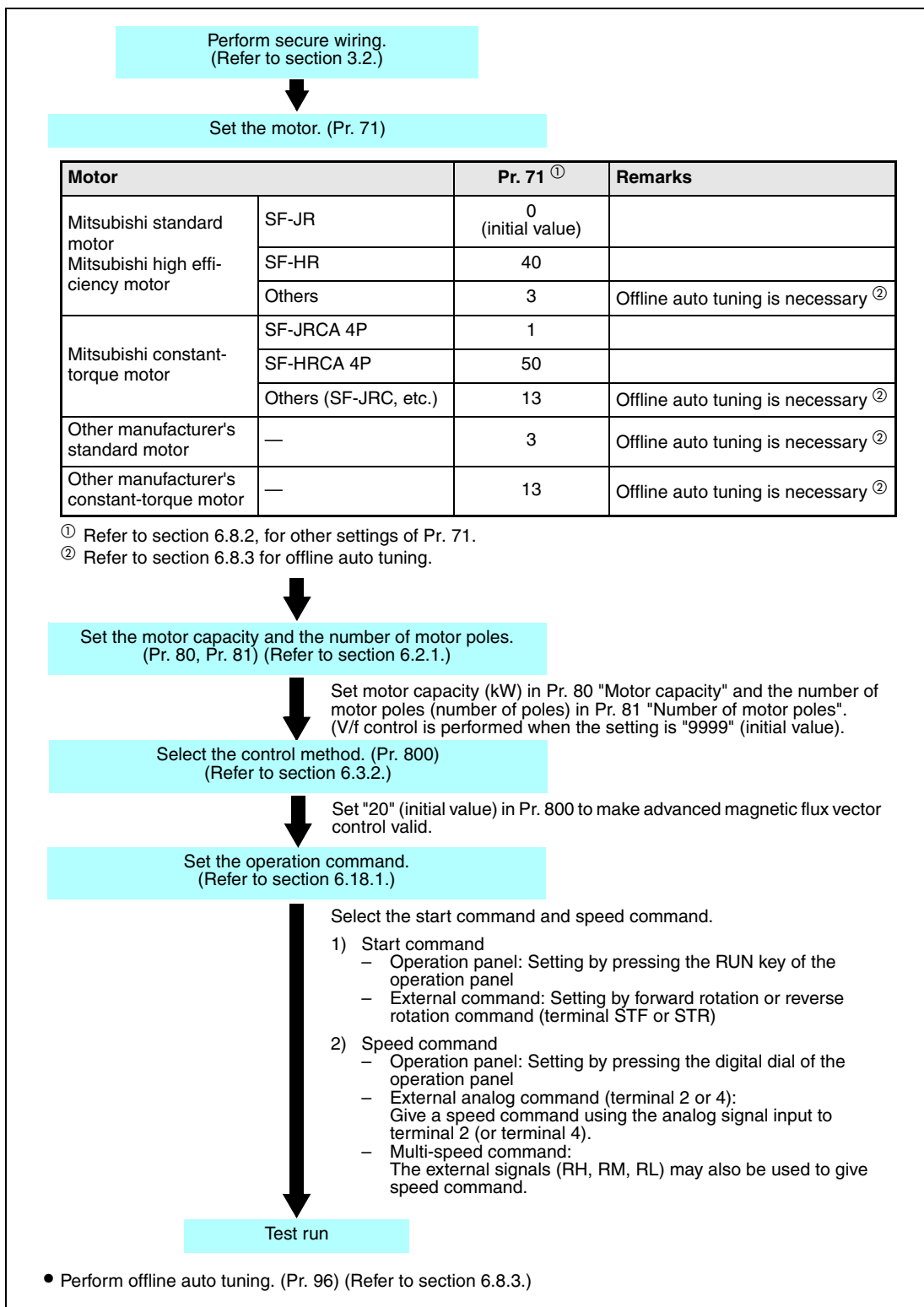

Fig. 6-2: Selection method of advanced magnetic flux vector control

NOTES

- Uneven rotation slightly increases as compared to the V/f control. It is not suitable for machines such as grinding machine and wrapping machine which requires less uneven rotation at low speed.
- When a surge voltage suppression filter (FFR-DT) is connected between the inverter and motor, output torque may decrease.

Adjust the motor speed fluctuation at load fluctuation

The motor speed fluctuation at load fluctuation can be adjusted using Pr. 89. (It is useful when the speed command does not match the motor speed after the FR-E500 series inverter is replaced with the FR-E700 series inverter, etc.)

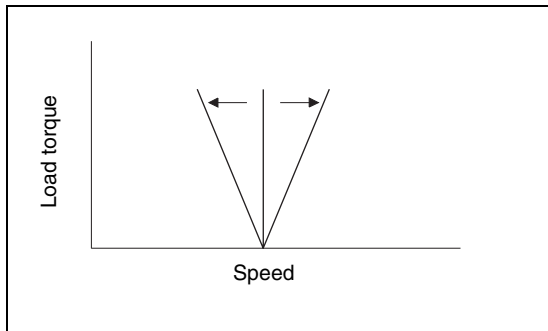
**Fig. 6-3:***Adjustment of speed fluctuations*

I001544E

6.3.3 General-purpose magnetic flux vector control (Pr. 71, Pr. 80, Pr. 81, Pr. 800)

General-purpose magnetic flux vector control is the same function as the FR-E500 series. Select this control when the same operation characteristic is necessary. For other cases, select advanced magnetic flux vector control.

| Pr. No. | Name | Initial Value | Setting Range | Description | Parameters referred to | Refer to Section |
|---------|--------------------------|---------------|---|---|---|-----------------------------------|
| 71 | Applied motor | 0 | 0/1/3-6/13-16/ 23/24/40/43/44/ 50/53/54 | By selecting a standard motor or constant torque motor, thermal characteristic and motor constants of each motor are set. | 3 Base frequency 19 Base frequency 71 Applied motor 77 Parameter write selection | 6.5.1 6.5.1 6.8.2 6.17.2 |
| | | | 0.1-15kW | Applied motor capacity. | | |
| 80 | Motor capacity | 9999 | 9999 | V/f control | | |
| | | | 2/4/6/8/10 | Number of motor poles. | | |
| 81 | Number of motor poles | 9999 | 9999 | V/f control | | |
| | | | 20 | Advanced magnetic flux vector control ① | | |
| 800 | Control method selection | 20 | 30 | General-purpose magnetic flux vector control ① | | |

The above parameters can be set when Pr. 160 "User group read selection" = 0.

① Set a value other than "9999" in Pr. 80 and Pr. 81.

If the following conditions are not satisfied, select V/f control since malfunction such as insufficient torque and uneven rotation may occur.

- The motor capacity should be equal to or one rank lower than the inverter capacity.
- Motor to be used is any of Mitsubishi standard motor, high efficiency motor (SF-JR, SF-HR 0.2kW or more) or Mitsubishi constant-torque motor (SF-JRCA four-pole, SF-HRCA 0.4kW to 15kW). When using a motor other than the above (other manufacturer's motor), perform offline auto tuning without fail.
- Single-motor operation (one motor run by one inverter) should be performed.
- The wiring length from inverter to motor should be within 30m. (Perform offline auto tuning in the state where wiring work is performed when the wiring length exceeds 30m.)
- Permissible wiring length between inverter and motor differs according to the inverter capacity and setting value of Pr. 72 "PWM frequency selection" (carrier frequency). (Refer to page 3-12).

Selection method of general-purpose magnetic flux vector control

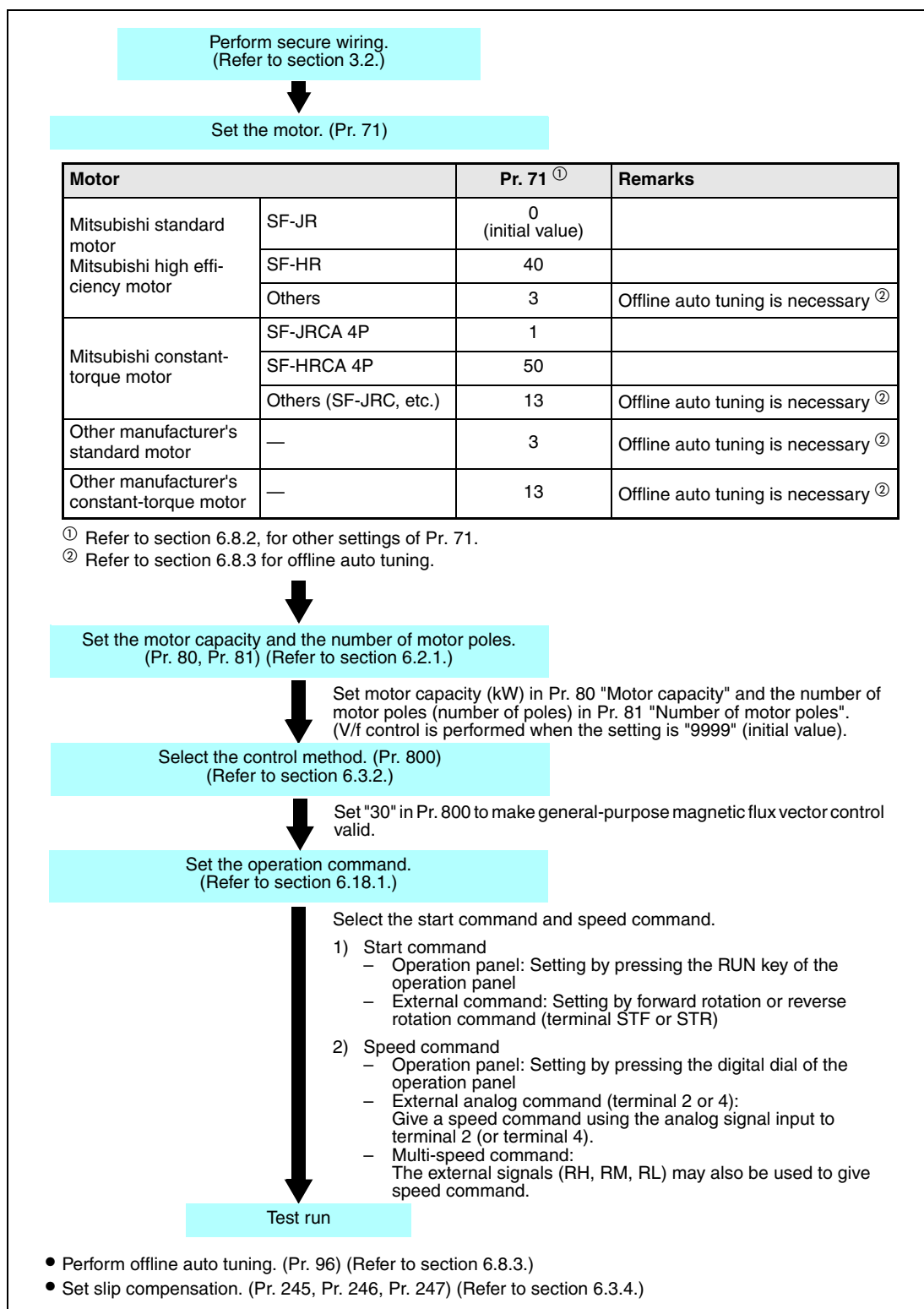

Fig. 6-4: Selection method of general-purpose magnetic flux vector control

NOTES

Uneven rotation slightly increases as compared to the V/f control. It is not suitable for machines such as grinding machine and wrapping machine which requires less uneven rotation at low speed.

When a surge voltage suppression filter (FFR-DT) is connected between the inverter and motor, output torque may decrease.

6.3.4 Slip compensation (Pr. 245 to Pr. 247)

When V/f control or general-purpose magnetic flux vector control is performed, the inverter output current may be used to assume motor slip to keep the motor speed constant.

| Pr. No. | Name | Initial Value | Setting Range | Description | Parameters referred to | Refer to Section |
|---------|--|---------------|---------------|--|---|------------------|
| 245 | Rated slip | 9999 | 0.01–50% | Rated motor slip. | 1 Maximum frequency 3 Base frequency | 6.4.1 6.5.1 |
| | | | 0/9999 | No slip compensation | | |
| 246 | Slip compensation time constant | 0.5s | 0.01–10s | Slip compensation response time. When the value is made smaller, response will be faster. However, as load inertia is greater, a regenerative overvoltage fault (E.OV□) is more liable to occur. | | |
| 247 | Constant-output region slip compensation selection | 9999 | 0 | Slip compensation is not made in the constant power range (frequency range above the frequency set in Pr. 3) | | |
| | | | 9999 | Slip compensation is made in the constant power range. | | |

The above parameters can be set when Pr. 160 "User group read selection" = 0.

Slip compensation is validated when the motor rated slip calculated by the following formula is set to Pr. 245. Slip compensation is not made when Pr. 245 = 0 or 9999.

$$\text{Rated slip} = \frac{\text{Synchronous speed at base frequency} - \text{Rated speed}}{\text{Synchronous speed at base frequency}} \times 100\%$$

NOTES

When performing slip compensation, the output frequency may become greater than the set frequency. Set the Pr. 1 "Maximum frequency" value a little higher than the set frequency.

Slip compensation is always valid when advanced magnetic flux vector control is selected, the Pr. 245 to Pr. 247 settings are invalid.

6.3.5 Stall prevention operation (Pr. 22, Pr. 23, Pr. 48, Pr. 66, Pr. 156, Pr. 157, Pr. 277)

This function monitors the output current and automatically changes the output frequency to prevent the inverter from coming to trip due to overcurrent, overvoltage, etc. In addition, simple torque limit which limits the output torque to the predetermined value can be selected.

It can also limit stall prevention and fast-response current limit operation during acceleration/deceleration, driving or regeneration.

- **Stall prevention**
If the output current exceeds the stall prevention operation level, the output frequency of the inverter is automatically varied to reduce the output current.
- **Fast-response current limit**
If the current exceeds the limit value, the output of the inverter is shut off to prevent an overcurrent.
- **Torque limit**
The inverter output frequency is controlled so that the output torque (torque current) will not exceed the stall prevention operation level (motor rated torque is referenced).

| Pr. No. | Name | Initial Value | Setting Range | Description |
|---------|--|---------------|------------------|---|
| 22 | Stall prevention operation level | 150% | 0 | Stall prevention operation invalid |
| | | | 0.1–120% | Set the current value to start the stall prevention operation. |
| 23 | Stall prevention operation level compensation factor at double speed | 9999 | 0–200% | The stall operation level can be reduced when operating at a high speed above the rated frequency. |
| | | | 9999 | Constant according to Pr. 22. |
| 48 | Second stall prevention operation current | 9999 | 0 | Stall prevention operation invalid |
| | | | 0.1–200% | Second stall prevention operation level |
| | | | 9999 | Same level as Pr. 22. |
| 66 | Stall prevention operation reduction starting frequency | 50Hz | 0–400Hz | Set the frequency at which the stall operation level is started to reduce. |
| 156 | Stall prevention operation selection | 0 | 0–31/ 100/101 | Select whether stall prevention operation and fast-response current limit operation will be performed or not. |
| 157 | OL signal output timer | 0s | 0–25s | Output start time of the OL signal output when stall prevention is activated. |
| | | | 9999 | Without the OL signal output |
| 277 | Stall prevention operation current switchover | 0 | 0 | Output current is the limit level |
| | | | 1 | Output torque (torque current) is the limit level |

| Parameters referred to | Refer to Section |
|--|------------------|
| 3 Base frequency | 6.5.1 |
| 178–184 Input terminal function selection | 6.10.1 |
| 190–192 Output terminal function selection | 6.10.5 |

The above parameters can be set when Pr. 160 "User group read selection" = 0.

Block diagram

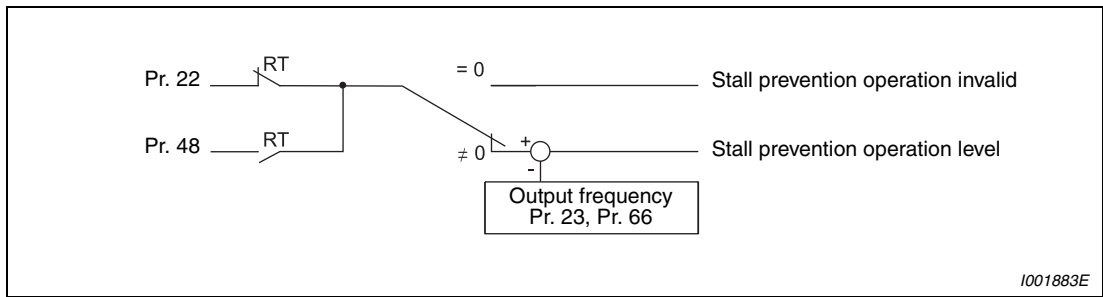

Fig. 6-5: Stall prevention block diagram

Setting of stall prevention operation level (Pr. 22)

Set in Pr. 22 the percentage of the output current to the rated inverter current at which stall prevention operation will be performed. Normally set this parameter to 150% (initial value).

Stall prevention operation stops acceleration (makes deceleration) during acceleration, makes deceleration during constant speed, and stops deceleration (makes acceleration) during deceleration.

When stall prevention operation is performed, the OL signal is output.

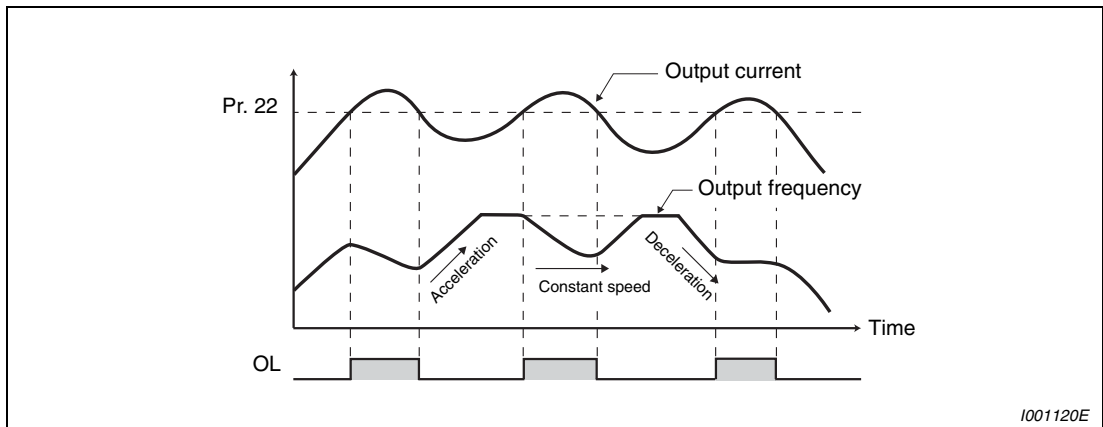

Fig. 6-6: Stall prevention operation example

NOTE

If an overload status lasts long, an inverter trip (e.g. electronic thermal relay function "E.THM") may occur.

A machine protection and load limit by torque limit (Pr. 277)

When Pr. 277 "Stall prevention current switchover" = 1, torque limit can be set.

When output torque (torque current) exceeds the stall prevention operation level, the output frequency is controlled to limit the output torque. For the stall prevention operation level at this time, the motor rated torque is defined as reference.

NOTES

When driving multiple motors with one inverter, torque limit does not function properly.

Since magnetic flux decreases in the constant output range (Pr. 3 "Base frequency" or more), the inverter operate with lower torque than the stall prevention operation level.

When torque limit is activated during regeneration, the output frequency is increased up to the maximum frequency.

Torque limit does not function at 5Hz or less during deceleration.

Note the following when using torque limit under V/f control.

- Capacity of the inverter and motor should be the same.
- Stall prevention operation level (torque limit level) is the rated torque reference of the motor whose capacity is equivalent to the inverter.
- When Pr. 0 "Torque boost" setting is large, torque limit is likely to occur in the low speed range.
- Use the advanced magnetic flux vector control when more appropriate torque limit is necessary.

Stall prevention operation signal output and output timing adjustment (OL signal, Pr. 157)

When the output current exceeds the stall prevention operation level and stall prevention is activated, the stall prevention operation signal (OL signal) turns on for longer than 100ms. When the output current falls to or below the stall prevention operation level, the output signal turns off. Use Pr. 157 "OL signal output timer" to set whether the OL signal is output immediately or after a preset period of time.

This operation is also performed when the regeneration avoidance function or oL (overvoltage stall) is executed.

For the OL signal, set "3 (positive logic) or 103 (negative logic)" in Pr. 190 to Pr. 192 "Output terminal function selection" and assign functions to the output terminal.

| Pr. 157 Setting | Description |
|-----------------|--|
| 0 | Output immediately. |
| 0.1–25s | Output after the set time (s) has elapsed. |
| 9999 | Not output. |

Tab. 6-3: Setting of parameter 157

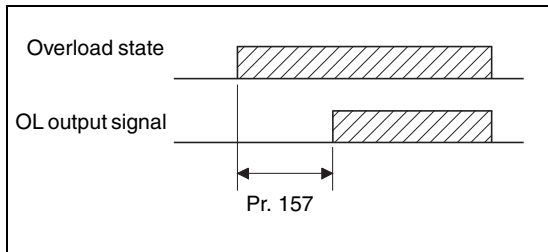

Fig. 6-7:
Output of the OL signal

1001330E

NOTES

If the frequency has fallen to 1Hz by stall prevention operation and remains for 3s, a fault (E.OLT) appears to trip the inverter output.

Changing the terminal assignment using Pr. 190 to Pr. 192 "Output terminal function selection" may affect the other functions. Make setting after confirming the function of each terminal.

Setting of stall prevention operation in high frequency range (Pr. 22, Pr. 23, Pr. 66)

During high-speed operation above the rated motor frequency, acceleration may not be made because the motor current does not increase. If operation is performed in a high frequency range, the current at motor lockup becomes smaller than the rated output current of the inverter, and the protective function (OL) is not executed if the motor is at a stop.

To improve the operating characteristics of the motor in this case, the stall prevention level can be reduced in the high frequency region. This function is effective for performing operation up to the high-speed range on a centrifugal separator etc.

Pr. 23 sets the change in the current limiting in the frequency range starting at the frequency set by Pr. 66. For example, if Pr. 66 is set to 75Hz the motor stall prevention operation level at an output frequency of 150Hz will be reduced to 75% when Pr. 23 is set to 100%, and to 66% when Pr. 23 is set to 50% (see the formula below). Generally Pr. 66 is set to 50Hz and Pr. 23 to 100%.

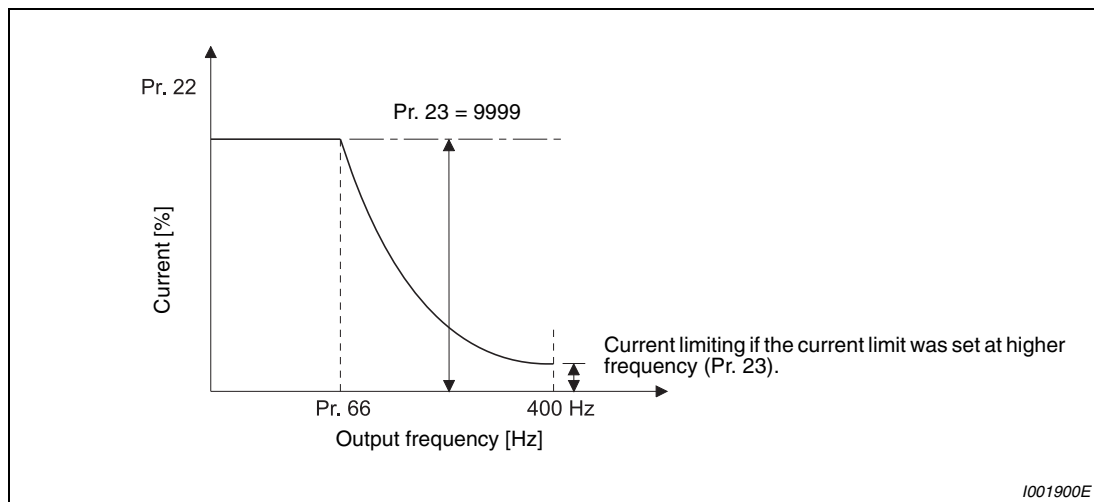

Fig. 6-8: Stall prevention operation level

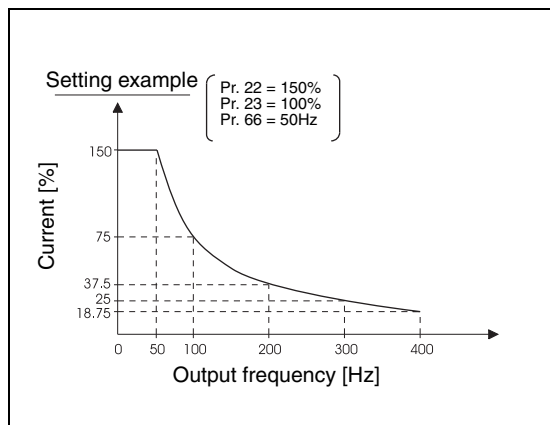

Fig. 6-9:

Stall prevention operation level when
Pr. 22 = 150 %, Pr. 23 = 100 % and
Pr. 66 = 50 Hz

Formula for stall prevention operation level:

$$\text{Stall prevention operation level [\%]} = A + B \times \left[\frac{\text{Pr. 22} - A}{\text{Pr. 22} - B} \right] \times \left[\frac{\text{Pr. 23} - 100}{100} \right]$$

$$\text{where } A = \frac{\text{Pr. 66 [Hz]} \times \text{Pr. 22 [\%]}}{\text{Output frequency [Hz]}}, \quad B = \frac{\text{Pr. 66 [Hz]} \times \text{Pr. 22 [\%]}}{400\text{Hz}}$$

When Pr. 23 "Stall prevention operation level compensation factor at double speed" = 9999 (initial value), the stall prevention operation level is kept constant at the Pr. 22 setting up to 400Hz.

Set two types stall prevention operation levels (Pr. 48)

Turning RT signal on makes Pr. 48 "Second stall prevention operation current" valid.

For the terminal used for RT signal input, set "3" in any of Pr. 178 to Pr. 184 "Input terminal function selection" to assign the function.

NOTES

Changing the terminal assignment using Pr. 178 to Pr. 184 "Input terminal function selection" may affect the other functions. Make setting after confirming the function of each terminal.

The RT signal acts as the second function selection signal and makes the other second functions valid.

Limit the stall prevention operation and fast-response current limit operation according to the operating status (Pr. 156)

Refer to the following table and select whether fast-response current limit operation will be performed or not and the operation to be performed at OL signal output:

| Pr. 156 Setting | Fast-response Current Limit ^③ | Stall Prevention Operation Level | | | OL Signal Output | |
|--------------------|--|----------------------------------|----------------|--------------|------------------|-------------------------|
| | | Acceleration | Constant speed | Deceleration | Without alarm | Stop with alarm „E.OLT“ |
| 0 | ✓ | ✓ | ✓ | ✓ | ✓ | — |
| 1 | — | ✓ | ✓ | ✓ | ✓ | — |
| 2 | ✓ | — | ✓ | ✓ | ✓ | — |
| 3 | — | — | ✓ | ✓ | ✓ | — |
| 4 | ✓ | ✓ | — | ✓ | ✓ | — |
| 5 | — | ✓ | — | ✓ | ✓ | — |
| 6 | ✓ | — | — | ✓ | ✓ | — |
| 7 | — | — | — | ✓ | ✓ | — |
| 8 | ✓ | ✓ | ✓ | — | ✓ | — |
| 9 | — | ✓ | ✓ | — | ✓ | — |
| 10 | ✓ | — | ✓ | — | ✓ | — |
| 11 | — | — | ✓ | — | ✓ | — |
| 12 | ✓ | ✓ | — | — | ✓ | — |
| 13 | — | ✓ | — | — | ✓ | — |
| 14 | ✓ | — | — | — | ① | ① |
| 15 | — | — | — | — | ① | ① |
| 16 | ✓ | ✓ | ✓ | ✓ | — | ✓ |
| 17 | — | ✓ | ✓ | ✓ | — | ✓ |
| 18 | ✓ | — | ✓ | ✓ | — | ✓ |
| 19 | — | — | ✓ | ✓ | — | ✓ |
| 20 | ✓ | ✓ | — | ✓ | — | ✓ |
| 21 | — | ✓ | — | ✓ | — | ✓ |
| 22 | ✓ | — | — | ✓ | — | ✓ |
| 23 | — | — | — | ✓ | — | ✓ |
| 24 | ✓ | ✓ | ✓ | — | — | ✓ |
| 25 | — | ✓ | ✓ | — | — | ✓ |
| 26 | ✓ | — | ✓ | — | — | ✓ |
| 27 | — | — | ✓ | — | — | ✓ |
| 28 | ✓ | ✓ | — | — | — | ✓ |
| 29 | — | ✓ | — | — | — | ✓ |
| 30 | ✓ | — | — | — | ① | ① |
| 31 | — | — | — | — | ① | ① |
| 100 D ^② | ✓ | ✓ | ✓ | ✓ | ✓ | — |
| 100 R ^② | — | — | — | — | ① | ① |
| 101 D ^② | — | ✓ | ✓ | ✓ | ✓ | — |
| 101 R ^② | — | — | — | — | ① | ① |

Tab. 6-4: Setting of parameter 156 (D = Driving, R = Regeneration)

- ① Since both fast-response current limit and stall prevention are not activated, OL signal and E.OLT are not output.
- ② The settings "100" and "101" allow operations to be performed in the driving and regeneration modes, respectively. The setting "101" disables the fast-response current limit in the driving mode.
- ③ OL signal is not output at fast-response current limit operation.

NOTES

When the load is heavy or the acceleration/deceleration time is short, stall prevention is activated and acceleration/deceleration may not be made according to the preset acceleration/deceleration time. Set Pr. 156 and stall prevention operation level to the optimum values.

In vertical lift applications, make setting so that the fast-response current limit is not activated. Torque may not be produced, causing a drop due to gravity.

**CAUTION:**

- *Do not set a small value as the stall prevention operation current. Otherwise, torque generated will reduce.*
- *Always perform test operation.*
Stall prevention operation during acceleration may increase the acceleration time.
Stall prevention operation performed during constant speed may cause sudden speed changes.
Stall prevention operation during deceleration may increase the deceleration time, increasing the deceleration distance.

6.4 Limit the output frequency

| Purpose | Parameters that must be set | | Refer to Section |
|--|-----------------------------|----------------------|------------------|
| Set upper limit and lower limit of output frequency | Maximum/minimum frequency | Pr. 1, Pr. 2, Pr. 18 | 6.4.1 |
| Perform operation by avoiding machine resonance points | Frequency jump | Pr. 31–Pr. 36 | 6.4.2 |

6.4.1 Maximum and minimum frequency (Pr. 1, Pr. 2, Pr. 18)

You can limit the motor speed. Clamp the upper and lower limits of the output frequency.

| Pr. No. | Name | Initial Value | Setting Range | Description | Parameters referred to | Refer to Section |
|-----------|---|---------------|---------------|--|---|------------------|
| 1 | Maximum frequency | 120Hz | 0–120Hz | Set the upper limit of the output frequency. | 13 Starting frequency 15 Jog frequency | 6.7.2 6.6.2 |
| 2 | Minimum frequency | 0Hz | 0–120Hz | Set the lower limit of the output frequency. | 125 Terminal 2 frequency setting gain frequency | 6.16.3 |
| 18 | High speed maximum frequency ^① | 120Hz | 120–400Hz | Set when performing the operation at 120Hz or more | 126 Terminal 4 frequency setting gain frequency | 6.16.3 |

① The above parameter can be set when Pr. 160 "User group read selection" = 0.

Set the maximum frequency

Set the upper limit of the output frequency in Pr. 1 "Maximum frequency". If the frequency of the frequency command entered is higher than the setting, the output frequency is clamped at the maximum frequency.

When you want to perform operation above 120Hz, set the upper limit of the output frequency to Pr. 18 "High speed maximum frequency". (When Pr. 18 is set, Pr. 1 automatically switches to the frequency of Pr. 18. When Pr. 18 is set, Pr. 18 automatically switches to the frequency of Pr. 1.)

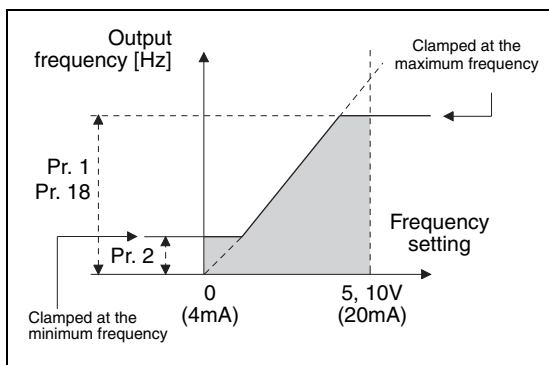

Fig. 6-10:
Maximum and minimum output frequency

1001100E

NOTE

When performing operation above 50Hz using the frequency setting analog signal, change Pr. 125 (Pr. 126) "Frequency setting gain". (Refer to section 6.16.3.) If only Pr. 1 or Pr. 18 is changed, operation above 50Hz cannot be performed.

Set the minimum frequency

Use Pr. 2 "Minimum frequency" to set the lower limit of the output frequency.

NOTES

When Pr. 15 "Jog frequency" is equal to or less than Pr. 2, the Pr. 15 setting has precedence over the Pr. 2 setting.

The output frequency is clamped by the Pr. 2 setting even the set frequency is lower than the Pr. 2 setting (The frequency will not decrease to the Pr. 2 setting.)

**CAUTION:**

If the Pr. 2 setting is higher than the Pr. 13 "Starting frequency" value, note that the motor will run at the set frequency according to the acceleration time setting by merely switching the start signal on, without entry of the command frequency.

6.4.2 Avoid mechanical resonance points (frequency jumps) (Pr. 31 to Pr. 36)

When it is desired to avoid resonance attributable to the natural frequency of a mechanical system, these parameters allow resonant frequencies to be jumped.

| Pr. No. | Name | Initial Value | Setting Range | Description |
|-----------|-------------------|---------------|---------------|---|
| 31 | Frequency jump 1A | 9999 | 0-400Hz/9999 | 1A to 1B, 2A to 2B, 3A to 3B is frequency jumps 9999: Function invalid |
| 32 | Frequency jump 1B | 9999 | 0-400Hz/9999 | |
| 33 | Frequency jump 2A | 9999 | 0-400Hz/9999 | |
| 34 | Frequency jump 2B | 9999 | 0-400Hz/9999 | |
| 35 | Frequency jump 3A | 9999 | 0-400Hz/9999 | |
| 36 | Frequency jump 3B | 9999 | 0-400Hz/9999 | |

| Parameters referred to | Refer to Section |
|------------------------|------------------|
| — | |

The above parameters can be set when Pr. 160 "User group read selection" = 0.

Up to three areas may be set, with the jump frequencies set to either the top or bottom point of each area.

The settings of frequency jumps 1A, 2A, 3A are jump points, and operation is performed at these frequencies in the jump areas.

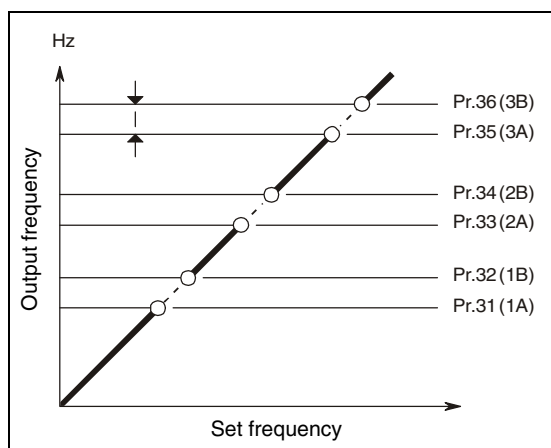

Fig. 6-11:
Definition of the jump areas

1000019C

The following diagrams show how the jump point is selected. The diagram on the left shows a sequence in which the jump takes place at the end of the area to be jumped, for which the lower frequency must be entered first. In the diagram on the right the jump takes place at the beginning of the frequency area to be jumped, for which the higher frequency must be entered first.

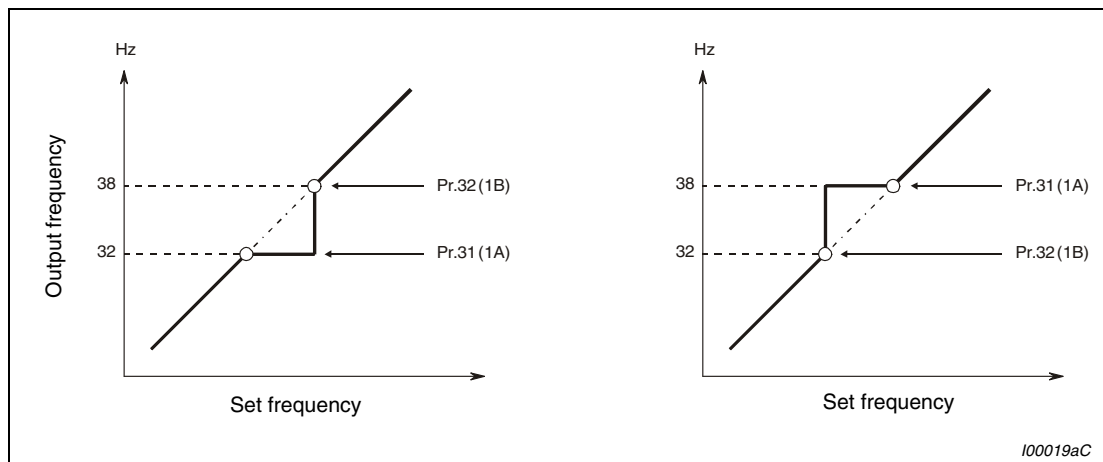

Fig. 6-12: Selection of the jump point

NOTE

During acceleration/deceleration, the running frequency within the set area is valid.

6.5 Set V/f pattern

| Purpose | Parameters that must be set | | Refer to Section |
|--|--|-----------------------|------------------|
| Set motor ratings | Base frequency, Base frequency voltage | Pr. 3, Pr. 19, Pr. 47 | 6.5.1 |
| Select a V/f pattern according to applications | Load pattern selection | Pr. 14 | 6.5.2 |

6.5.1 Base frequency, voltage (Pr. 3, Pr. 19, Pr. 47)

Used to adjust the inverter outputs (voltage, frequency) to the motor rating.

| Pr. No. | Name | Initial Value | Setting Range | Description | Parameters referred to | Refer to Section |
|-----------|--|---------------|---------------|---|--|------------------|
| 3 | Base frequency | 50Hz | 0–400Hz | Set the frequency when the motor rated torque is generated. (50Hz/60Hz) | | |
| 19 | Base frequency voltage ^① | 8888 | 0–1000V | Set the rated motor voltage. | 14 Load pattern selection | 6.5.2 |
| | | | 8888 | 95% of power supply voltage | 29 Acceleration/deceleration pattern selection | 6.7.3 |
| | | | 9999 | Same as power supply voltage | 83 Motor rated voltage | 6.8.3 |
| 47 | Second V/f (base frequency) ^① | 9999 | 0–400Hz | Set the base frequency when the RT signal is on. | 84 Rated motor frequency | 6.8.3 |
| | | | 9999 | Second V/f invalid | 178–184 Input terminal function selection | 6.10.1 |
| | | | | | General-purpose magnetic flux vector control | 6.3.3 |
| | | | | | Advanced magnetic flux vector control | 6.3.2 |

① The above parameter can be set when Pr. 160 "User group read selection" = 0.

Setting of base frequency (Pr. 3)

When operating a standard motor, generally set the rated frequency of the motor to Pr. 3 "Base frequency".

When running the motor using commercial power supply-inverter switch-over operation, set Pr. 3 to the same value as the power supply frequency.

If the frequency given on the motor rating plate is "60Hz" only, always set to "60Hz". It may result in an inverter trip due to overload. Caution must be taken especially when Pr. 14 "Load pattern selection" = "1" (variable torque load)

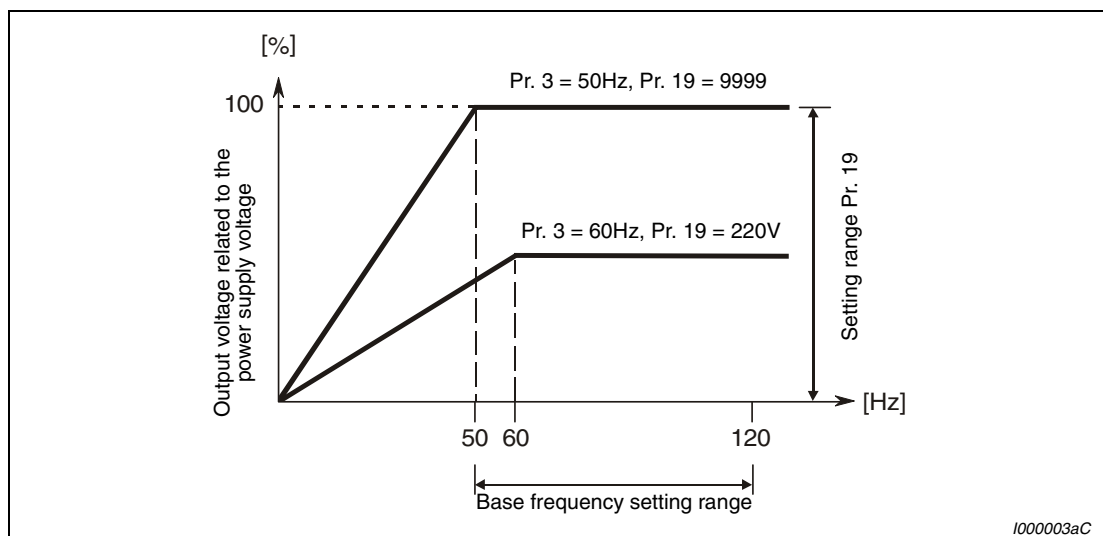

Fig. 6-13: Output voltage related to the output frequency

Set two kinds of base frequencies (Pr. 47)

Use the second base frequency when you want to change the base frequency, e.g. when using multiple motors by switching between them by one inverter.

Pr. 47 "Second V/f (base frequency)" is valid when the RT signal is on.

NOTES

The RT signal acts as the second function selection signal and makes the other second functions valid.

Set "3" in any of Pr. 178 to Pr. 184 "Input terminal function selection" and assign the RT signal.

Base frequency voltage setting (Pr. 19)

Use Pr. 19 "Base frequency voltage" to set the base voltage (e.g. rated motor voltage). If the setting is less than the power supply voltage, the maximum output voltage of the inverter is as set in Pr. 19.

Pr. 19 can be utilized in the following cases:

- When regeneration frequency is high (e.g. continuous regeneration)
During regeneration, the output voltage becomes higher than the reference and may cause an over current trip (E.O.C□) due to an increased motor current.
- When power supply voltage variation is large
When the power supply voltage exceeds the rated voltage of the motor, speed variation or motor overheat may be caused by excessive torque or increased motor current.

NOTES

When advanced magnetic flux vector control or general-purpose magnetic flux vector control is selected, Pr. 3, Pr. 47 and Pr. 19 are invalid and Pr. 83 and Pr. 84 are valid.

Note that Pr. 3 or Pr. 47 value is made valid as inflection points of S-pattern when Pr. 29 "Acceleration/deceleration pattern selection" = 1 (S-pattern acceleration/deceleration A).

Changing the terminal assignment using Pr. 178 to Pr. 184 "Input terminal function selection" may affect the other functions. Make setting after confirming the function of each terminal.

Note that the output voltage of the inverter cannot exceed the power supply voltage.

6.5.2 Load pattern selection (Pr. 14)

You can select the optimum output characteristic (V/f characteristic) for the application and load characteristics.

| Pr. No. | Name | Initial Value | Setting Range | Description | Parameters referred to | Refer to Section |
|---------|------------------------|---------------|---------------|---|--|------------------|
| 14 | Load pattern selection | 0 | 0 | For constant torque load | 0 Torque boost | 6.3.1 |
| | | | 1 | For variable torque load | 46 Second torque boost | 6.3.1 |
| | | | 2 | For constant torque elevators (at reverse rotation boost of 0%) | 3 Base frequency | 6.5.1 |
| | | | 3 | For constant torque elevators (at forward rotation boost of 0%) | 178-184 Input terminal function selection | 6.10.1 |
| | | | | | General-purpose magnetic flux vector control | 6.3.3 |
| | | | | | Advanced magnetic flux vector control | 6.3.2 |

The above parameter can be set when Pr. 160 "User group read selection" = 0.

For constant-torque load (Pr. 14 = 0, initial value)

At or less than the base frequency voltage, the output voltage varies linearly with the output frequency. Set this value when driving the load whose load torque is constant if the speed varies, e.g. conveyor, cart or roll drive.

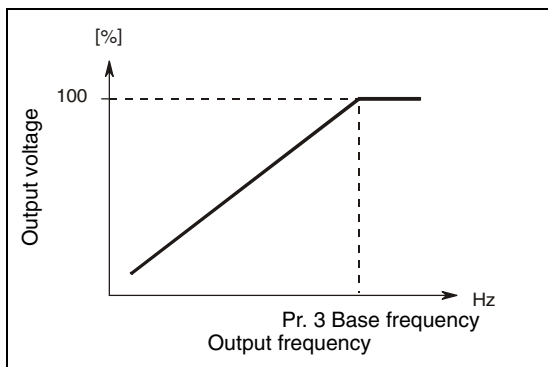

Fig. 6-14:
Constant-torque load

1001322C

For variable-torque load (Pr. 14 = 1)

At or less than the base frequency voltage, the output voltage varies with the output frequency in a square curve. Set this value when driving the load whose load torque varies in proportion to the square of the speed, e.g. fan or pump.

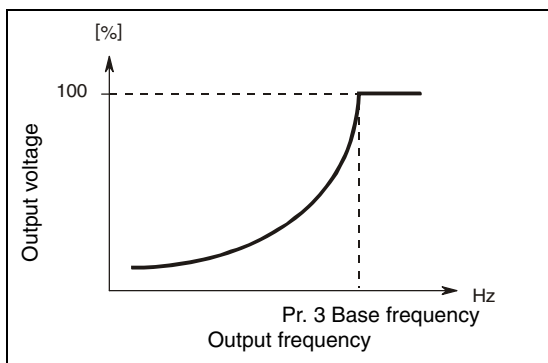

Fig. 6-15:
Variable-torque load

1001323C

Constant-torque load application (Pr. 14 = 2 or 3)

Set "2" when a vertical lift load is fixed as power driving load at forward rotation and regenerative load at reverse rotation.

Pr. 0 "Torque boost" is valid during forward rotation and torque boost is automatically changed to "0%" during reverse rotation. Pr. 46 "Second torque boost" is made valid when the RT signal turns on.

Set "3" for an elevated load that is in the driving mode during reverse rotation and in the regenerative load mode during forward rotation according to the load weight, e.g. counterweight system.

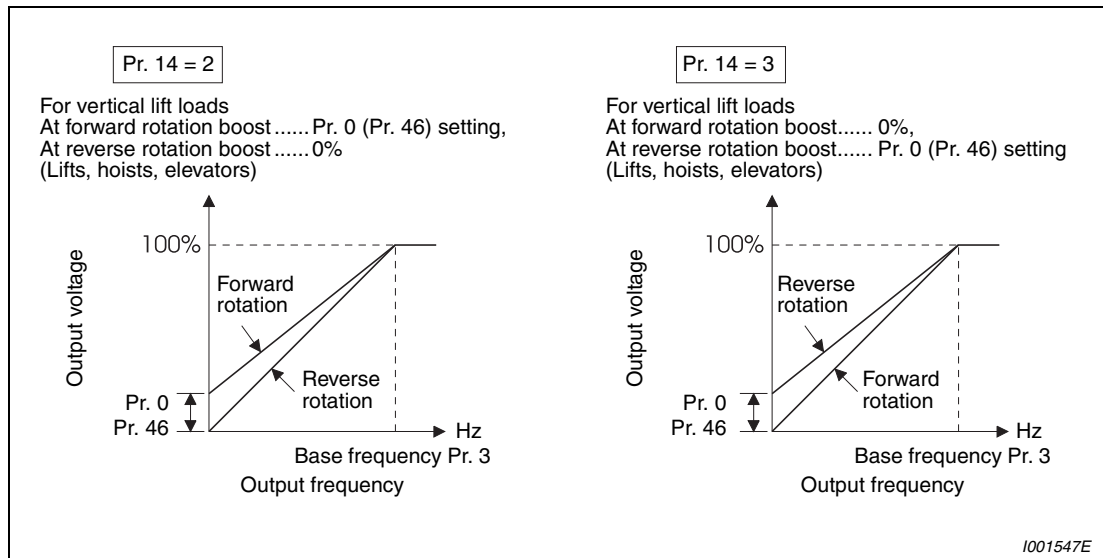

Fig. 6-16: Characteristic with manual torque boost

NOTES

For the RT signal, set "3" in any of Pr. 178 to Pr.184 "Input terminal function selection" to assign the function.

When torque is continuously regenerated as vertical lift load, it is effective to set the rated voltage in Pr. 19 "Base frequency voltage" to prevent trip due to current at regeneration.

In addition, when the RT signal is on, the other second functions are also valid.

Load pattern selection does not function under advanced magnetic flux vector control and general-purpose magnetic flux vector control.

Changing the terminal assignment using Pr. 178 to Pr. 184 "Input terminal function selection" may affect the other functions. Make setting after confirming the function of each terminal.

6.6 Frequency setting by external terminals

| Purpose | Parameters that must be set | | Refer to Section |
|--|-----------------------------|--|------------------|
| Make frequency setting by combination of terminals | Multi-speed operation | Pr. 4–Pr. 6, Pr. 24–Pr. 27 Pr. 232–Pr. 239 | 6.6.1 |
| Perform jog operation | Jog operation | Pr. 15, Pr. 16 | 6.6.2 |
| Infinitely variable speed setting by terminals | Remote setting function | Pr. 59 | 6.6.3 |

6.6.1 Multi-speed setting operation (Pr. 4 to Pr. 6, Pr. 24 to Pr. 27, Pr. 232 to Pr. 239)

Can be used to change the preset speed in the parameter with the contact signals.

Any speed can be selected by merely turning on-off the contact signals (RH, RM, RL, REX signals).

| Pr. No. | Name | Initial Value | Setting Range | Description | Parameters referred to | Refer to Section |
|------------|------------------------------------|---------------|---------------|---|--|------------------------------------|
| 4 | Multi-speed setting (high speed) | 50Hz | 0–400Hz | Set the frequency when RH turns on. | 15 JOG frequency 59 Remote function selection 79 Operation mode selection 178–184 Input terminal function selection | 6.6.2 6.6.3 6.18.1 6.10.1 |
| 5 | Multi-speed setting (middle speed) | 30Hz | 0–400Hz | Set the frequency when RM turns on. | | |
| 6 | Multi-speed setting (low speed) | 10Hz | 0–400Hz | Set the frequency when RL turns on. | | |
| 24 | Multi-speed setting (speed 4) ① | 9999 | 0–400Hz/9999 | Frequency from speed 4 to speed 15 can be set according to the combination of the RH, RM, RL and REX signals. 9999: not selected | | |
| 25 | Multi-speed setting (speed 5) ① | 9999 | 0–400Hz/9999 | | | |
| 26 | Multi-speed setting (speed 6) ① | 9999 | 0–400Hz/9999 | | | |
| 27 | Multi-speed setting (speed 7) ① | 9999 | 0–400Hz/9999 | | | |
| 232 | Multi-speed setting (speed 8) ① | 9999 | 0–400Hz/9999 | | | |
| 233 | Multi-speed setting (speed 9) ① | 9999 | 0–400Hz/9999 | | | |
| 234 | Multi-speed setting (speed 10) ① | 9999 | 0–400Hz/9999 | | | |
| 235 | Multi-speed setting (speed 11) ① | 9999 | 0–400Hz/9999 | | | |
| 236 | Multi-speed setting (speed 12) ① | 9999 | 0–400Hz/9999 | | | |
| 237 | Multi-speed setting (speed 13) ① | 9999 | 0–400Hz/9999 | | | |
| 238 | Multi-speed setting (speed 14) ① | 9999 | 0–400Hz/9999 | | | |
| 239 | Multi-speed setting (speed 15) ① | 9999 | 0–400Hz/9999 | | | |

The above parameters allow its setting to be changed during operation in any operation mode even if "0" (initial value) is set in Pr. 77 "Parameter write selection".

① The above parameters can be set when Pr. 160 "User group read selection" = 0.

Operation is performed at the frequency set in Pr. 4 when the RH signal turns on, Pr. 5 when the RM signal turns on, and Pr. 6 when the RL signal turns on.

Frequency from speed 4 to speed 15 can be set according to the combination of the RH, RM, RL and REX signals. Set the running frequencies in Pr. 24 to Pr. 27, Pr. 232 to Pr. 239. (In the initial value setting, speed 4 to speed 15 are unavailable.)

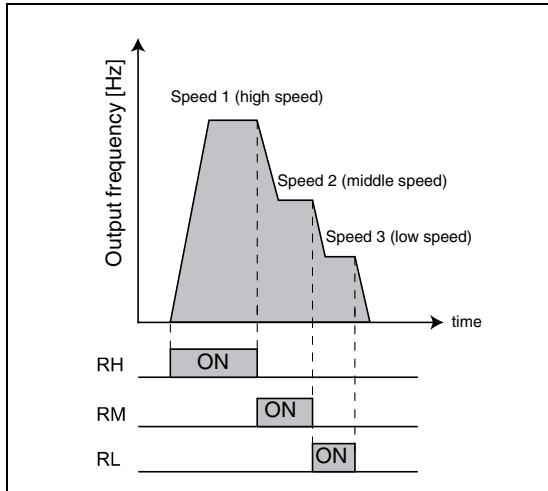

Fig. 6-17:
Multi-speed selection by external terminals

1002062E

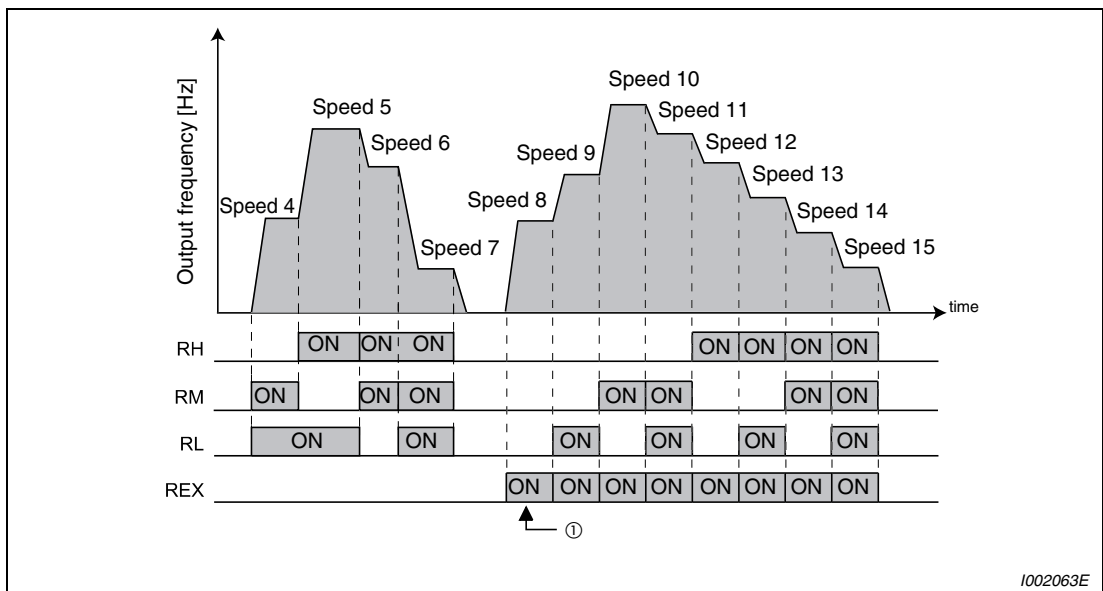

Fig. 6-18: Multi-speed selection by external terminals

1002063E

① When "9999" is set in Pr. 232 "Multi-speed setting (speed 8)", operation is performed at frequency set in Pr. 6 when RH, RM and RL are turned off and REX is turned on.

NOTES

In the initial setting, if two or three speeds are simultaneously selected, priority is given to the set frequency of the lower signal. For example, when the RH and RM signals turn on, the RM signal (Pr. 5) has a higher priority.

The RH, RM, RL signals are assigned to the terminal RH, RM, RL in the initial setting. By setting "0 (RL)", "1 (RM)", "2 (RH)" in any of Pr. 178 to Pr. 184 "Input terminal function assignment", you can assign the signals to other terminals.

For the terminal used for REX signal input, set "8" in any of Pr. 178 to Pr. 184 to assign the function.

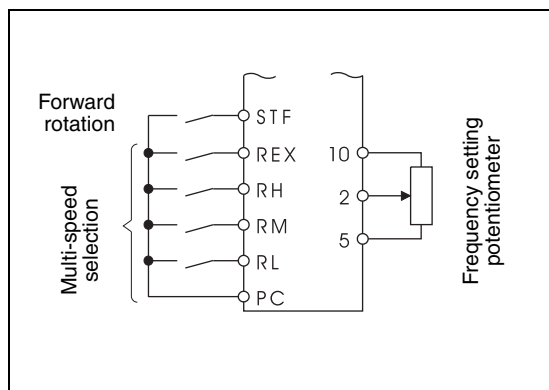

Fig. 6-19:
Connection example

1001127E

NOTES

The priorities of the frequency commands by the external signals are "jog operation > multi-speed operation > terminal 4 analog input > terminal 2 analog input". (Refer to section 6.16 for the frequency command by analog input.)

Valid in external operation mode or PU/external combined operation mode (Pr. 79 = 3 or 4).

Multi-speed parameters can also be set in the PU or external operation mode.

Pr. 24 to Pr. 27 and Pr. 232 to Pr. 239 settings have no priority between them.

When a value other than "0" is set in Pr. 59 "Remote function selection", the RH, RM and RL signals are used as the remote setting signals and the multi-speed setting becomes invalid.

The RH, RM, RL, REX signals can be assigned to the input terminal using any of Pr. 178 to Pr. 189 "Input terminal function selection". When terminal assignment is changed, the other functions may be affected. Please make setting after confirming the function of each terminal.

6.6.2 Jog operation (Pr. 15, Pr. 16)

You can set the frequency and acceleration/deceleration time for jog operation. Jog operation can be performed from either the outside or PU.

Can be used for conveyor positioning, test operation, etc.

| Pr. No. | Name | Initial Value | Setting Range | Description | Parameters referred to | Refer to Section |
|-----------|-------------------------------------|---------------|---------------|---|---|---|
| 15 | Jog frequency | 5Hz | 0–400Hz | Set the frequency for jog operation. | 13 Starting frequency | 6.7.2 |
| 16 | Jog acceleration/ deceleration time | 0.5s | 0–3600/360s | Acceleration/deceleration time for jog operation. This setting is related to the reference frequency set in Pr. 20 and the increments set in Pr. 21. Pr. 21 = 0 (Initial setting) Setting range: 0–3600s Increments: 0.1s Pr. 21 = 1 Setting range: 0–360 s Increments: 0.01s The acceleration and deceleration times cannot be set separately. | 29 Acceleration/deceleration pattern selection 20 Acceleration/deceleration reference frequency 21 Acceleration/ deceleration time increments 79 Operation mode selection 178–184 Input terminal function selection | 6.7.3 6.7.1 6.7.1 6.18.1 6.10.1 |

These parameters are displayed as simple mode parameter only when the parameter unit (FR-PU04/FR-PU07) is connected. When the parameter unit is not connected, the above parameters can be set when Pr. 160 "User group read selection" = 0.

Jog operation from outside

When the jog signal is on, a start and stop can be made by the start signal (STF, STR). For the terminal used for Jog operation selection, set "5" in any of Pr. 178 to Pr. 184 "Input terminal function selection" to assign the function.

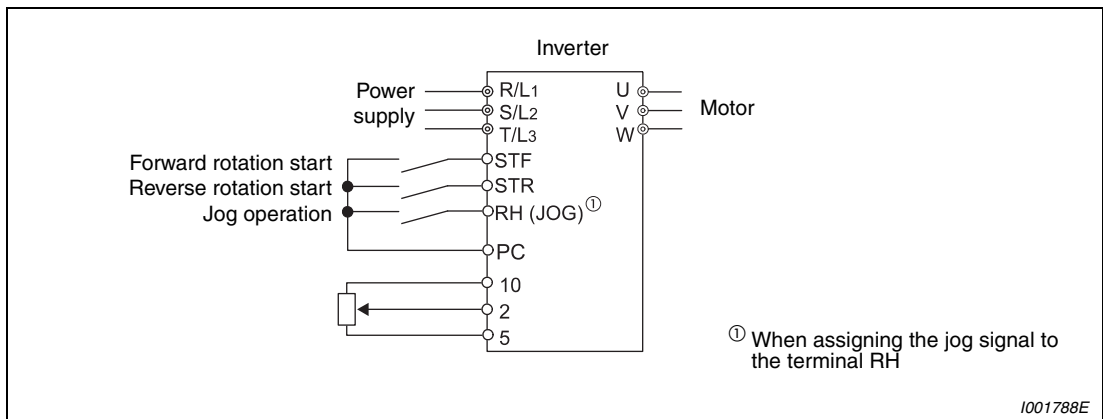

Fig. 6-20: Connection diagram for external jog operation

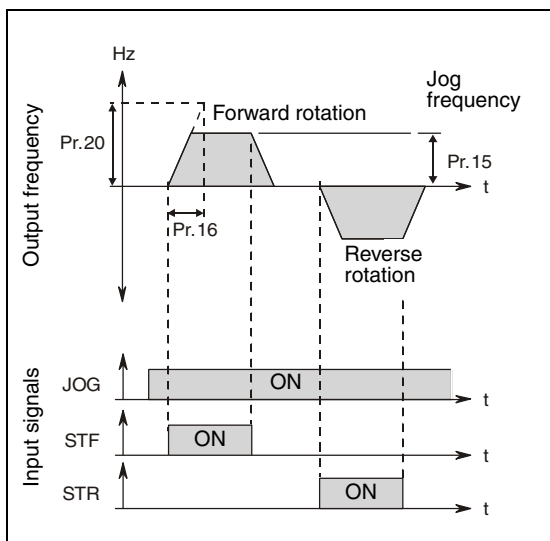

Fig. 6-21:
Jog operation signal timing chart

I001324C

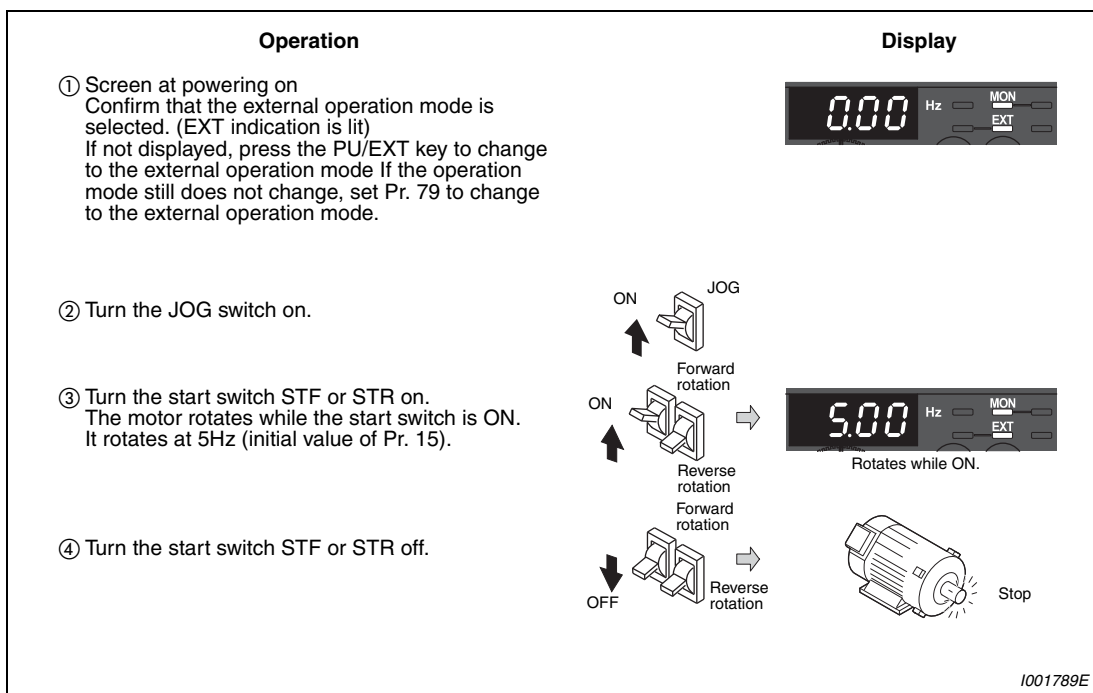

Fig. 6-22: Jog operation in the external operation mode

JOG operation from PU

Selects Jog operation mode from the operation panel and PU (FR-PU04/FR-PU07). Operation is performed only while the start button is pressed.

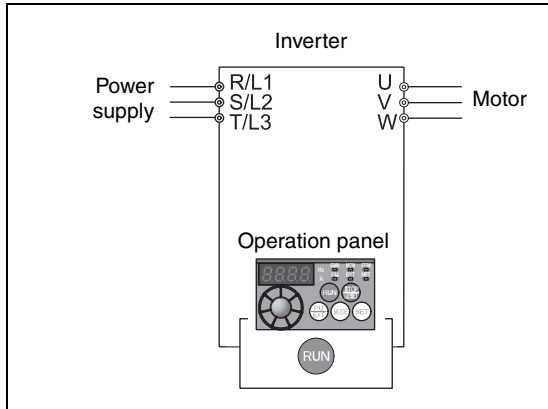

Fig. 6-23:
Connection example for jog operation performed from PU

I001790E

| Operation | Display |
|---|---------|
| ① Confirmation of the RUN indication and operation mode indication. The monitor mode must have been selected. The inverter must be at a stop. | |
| ② Press the PU/EXT key to choose the PU JOG operation mode. | |
| ③ Press the RUN key. The motor rotates while the key is pressed. It rotates at 5Hz (initial value of Pr. 15). | |
| ④ Release the RUN key to stop the motor. | |
| When changing the frequency of PU JOG operation: | |
| ⑤ Press the MODE key to choose the parameter setting mode. | |
| ⑥ Turn the digital dial until Pr. 15 "JOG frequency" appears. | |
| ⑦ Press the SET key to show the currently set value (5Hz). | |
| ⑧ Turn the digital dial to set the value to "10.00" (10.00Hz). | |
| ⑨ Press the SET key to set. | |
| ⑩ Perform the operations in steps ① to ④ The motor rotates at 10Hz. | |

I001791E

Fig. 6-24: JOG operation performed from PU

NOTES

When Pr. 29 "Acceleration/deceleration pattern selection" = "1" (S-pattern acceleration/deceleration A), the acceleration/deceleration time is the period of time required to reach Pr. 3 "Base frequency".

The Pr. 15 setting should be equal to or higher than the Pr. 13 "Starting frequency setting".

The JOG signal can be assigned to the input terminal using any of Pr. 178 to Pr. 184 "Input terminal function selection". When terminal assignment is changed, the other functions may be affected. Please make setting after confirming the function of each terminal.

During jog operation, the second acceleration/deceleration via the RT signal cannot be selected. (The other second functions are valid (refer to section 6.10.3)).

When Pr. 79 "Operation mode selection" = 4, push the RUN key of the operation panel or the FWD/REV key of the PU (FR-PU04/FR-PU07) to make a start or push the STOP/RESET key to make a stop.

This function is invalid when Pr. 79 = 3.

6.6.3 Remote setting function (Pr. 28)

Even if the operation panel is located away from the enclosure, you can use contact signals to perform continuous variable-speed operation, without using analog signals.

| Pr. No. | Name | Initial Value | Setting Range | Description | | Parameters referred to | Refer to Section |
|-----------|---------------------------|---------------|---------------|-------------------------------|--|---|------------------|
| | | | | RH, RM and RL signal function | Frequency setting storage function | | |
| 59 | Remote function selection | 0 | 0 | Multi-speed setting | — | 1 Maximum frequency | 6.4.1 |
| | | | 1 | Remote setting | ✓ | 18 High speed maximum frequency | 6.4.1 |
| | | | 2 | Remote setting | — | 7 Acceleration time | 6.7.1 |
| | | | 3 | Remote setting | (Turning STF/STR off clears remote setting frequency.) | 8 Deceleration time | 6.7.1 |
| | | | | | | 44 Second acceleration/deceleration time | 6.7.1 |
| | | | | | | 45 Second deceleration time | 6.7.1 |
| | | | | | | 178-184 Input terminal function selection | 6.10.1 |

The above parameter can be set when Pr. 160 "User group read selection" = 0.

Pr. 59 can be used to select a digital motor potentiometer. Setting Pr. 59 to a value of "1" activates the frequency setting storage function, so that the stored value is also stored when the power is switched off. The last frequency value is stored in the E²PROM. The delete instruction only applies to the data stored in RAM.

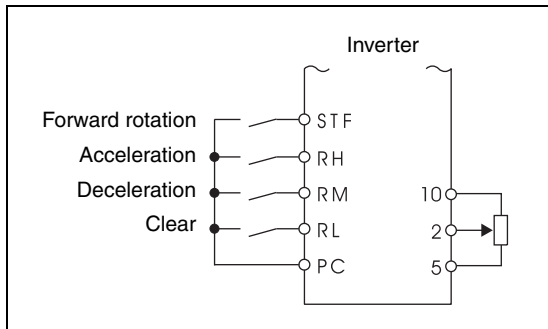
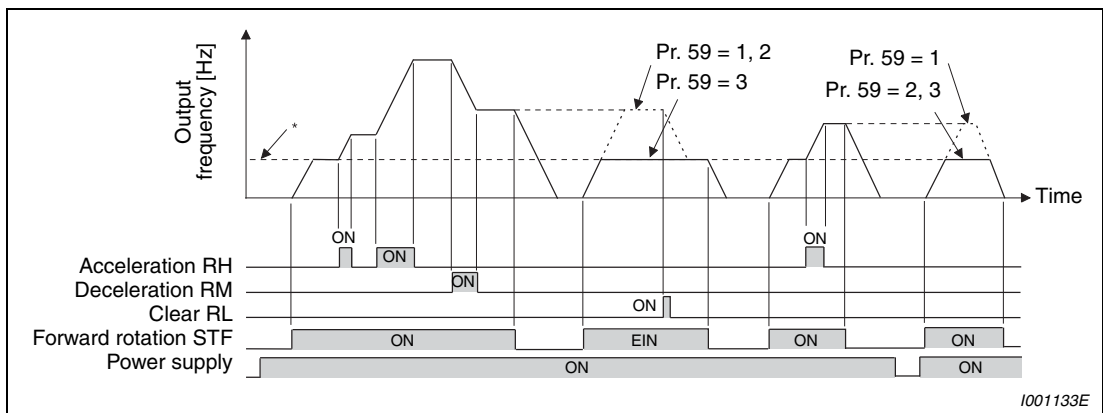

Fig. 6-25:
Connection diagram for remote setting

I001132E

When Pr. 59 is set to any of "1 to 3" (remote setting function valid), the functions of the RH, RM and RL signals are changed: RH ⇒ acceleration, RM ⇒ deceleration and RL ⇒ clear.



I001133E

Fig. 6-26: Example of the remote setting function

* External operation frequency (other than multi-speed) or PU running frequency.

Remote setting function

When using the remote setting function, following frequencies can be compensated to the frequency set by RH and RM operation according to the operation mode.

During external operation (including Pr. 79 = 4):

external frequency
command other than
multi-speed settings

During external operation and PU combined operation (Pr. 79 = 3): PU frequency command
or terminal 4 input.

During PU operation:

PU frequency command

Frequency setting storage

The frequency setting storage function stores the remotely-set frequency (frequency set by RH/RM operation) into the memory (E²PROM). When power is switched off once, then on, operation is resumed with that output frequency value. (Pr. 59 = 1)

The frequency is stored at the point when the start signal (STF or STR) turns off or every one minute after one minute has elapsed since turn off (on) of both the RH (acceleration) and RM (deceleration) signals. (The frequency is written if the present frequency setting compared with the past frequency setting every one minute is different. The state of the RL signal does not affect writing.)

NOTES

The range of frequency changeable by RH (acceleration) and RM (deceleration) is 0 to maximum frequency (Pr. 1 or Pr. 18 setting). Note that the maximum value of set frequency is (main speed + maximum frequency).

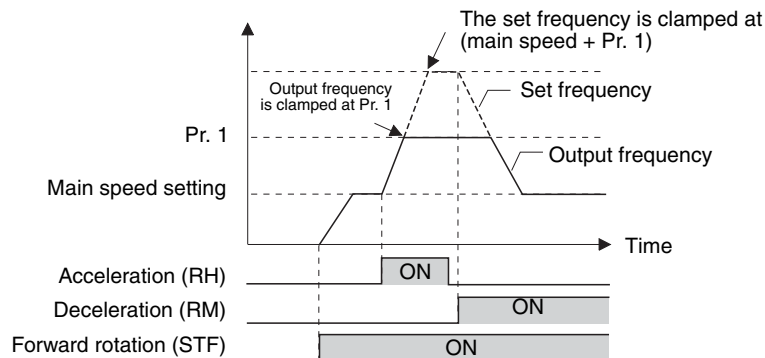

When the acceleration or deceleration signal switches on, acceleration/deceleration time is as set in Pr. 44 and Pr. 45. Note that when long time has been set in Pr. 7 or Pr. 8, the acceleration/deceleration time is as set in Pr. 7 or Pr. 8 (when RT signal is off).

When the RT signal is on, acceleration/deceleration is made in the time set to Pr. 44 and Pr. 45, regardless of the Pr. 7 or Pr. 8 setting.

If the start signal (STF or STR) is off, turning on the acceleration (RH) or deceleration (RM) signal varies the preset frequency.

When switching the start signal from ON to OFF, or changing frequency by the RH or RM signal frequently, set the frequency setting value storage function (write to E²PROM) invalid (Pr. 59 = 2 or 3). If set valid (Pr. 59 = 1), frequency is written to E²PROM frequently, this will shorten the life of the E²PROM.

The RH, RM, RL signals can be assigned to the input terminal using any Pr. 178 to Pr. 184 "Input terminal function selection". When terminal assignment is changed, the other functions may be affected. Please make setting after confirming the function of each terminal.

Also available for the network operation mode.

During jog operation or PID control operation, the remote setting function is invalid.

Set frequency = 0 Hz

- Even when the remotely-set frequency is cleared by turning on the RL (clear) signal after turn off (on) of both the RH and RM signals, the inverter operates at the remotely-set frequency stored in the last operation if power is reapplied before one minute has elapsed since turn off (on) of both the RH and RM signals.

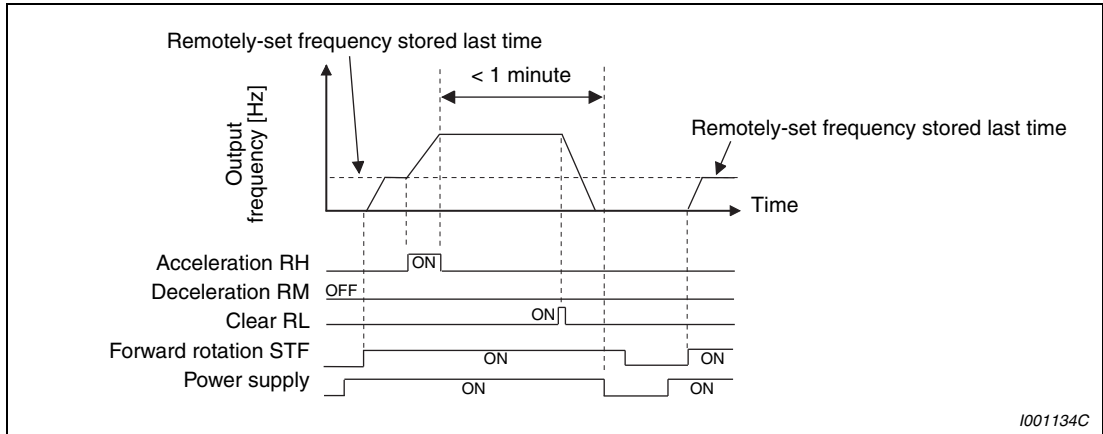

Fig. 6-27: Outputting the remotely-set frequency stored last time

- When the remotely-set frequency is cleared by turning on the RL (clear) signal after turn off (on) of both the RH and RM signals, the inverter operates at the frequency in the remotely-set frequency cleared state if power is reapplied after one minute has elapsed since turn off (on) of both the RH and RM signals.

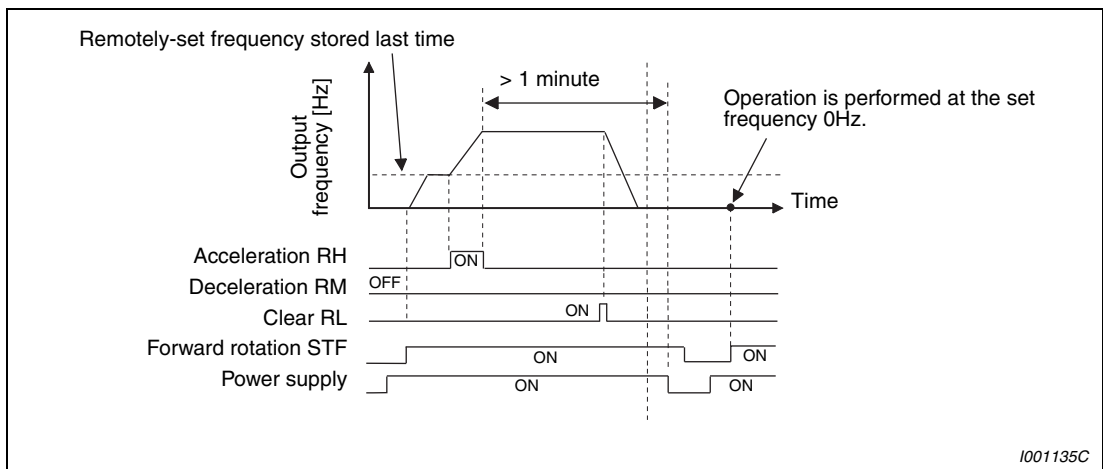

Fig. 6-28: Outputting the current set frequency



CAUTION:
 When Pr. 59 is set to "1" the motor will restart automatically after a power failure if there is an active rotation direction signal.

6.7 Acceleration and deceleration

| Purpose | Parameters that must be set | | Refer to Section |
|--|--|---|------------------|
| Motor acceleration/deceleration time setting | Acceleration/deceleration times | Pr. 7, Pr. 8, Pr. 20, Pr. 21, Pr. 44, Pr. 45, Pr. 147 | 6.7.1 |
| Starting frequency | Starting frequency and start-time hold | Pr. 13, Pr. 571 | 6.7.2 |
| Set acceleration/deceleration pattern suitable for application | Acceleration/deceleration pattern | Pr. 29 | 6.7.3 |
| Automatically set optimum acceleration/deceleration time | Automatic acceleration/deceleration | Pr. 61–Pr. 63, Pr. 292 | 6.7.4 |

6.7.1 Acceleration and deceleration time (Pr. 7, Pr. 8, Pr. 20, Pr. 21, Pr. 44, Pr. 45, Pr. 147)

Used to set motor acceleration/deceleration time. Set a larger value for a slower speed increase/decrease or a smaller value for a faster speed increase/decrease.

| Pr. No. | Name | Initial Value | | Setting Range | Description | Parameters referred to | Refer to Section |
|---------|---|---|-----|---------------------------------|---|--|------------------|
| 7 | Acceleration time | FR-E720S-110 or less, FR-E740-095 or less | 5s | 0–3600s/ 0–360s ^② | Set the motor acceleration time. | 3 Base frequency 29 Acceleration/deceleration pattern selection | 6.5.1 6.7.3 |
| | | FR-E740-120 and 170 | 10s | | | | |
| | | FR-E740-230 and 300 | 15s | | | | |
| 8 | Deceleration time | FR-E720S-110 or less, FR-E740-095 or less | 5s | 0–3600s/ 0–360s ^② | Set the motor deceleration time. | 125 Frequency setting gain frequency 126 Frequency setting gain frequency | 6.16.3 |
| | | FR-E740-120 and 170 | 10s | | | | |
| | | FR-E740-230 and 300 | 15s | | | | |
| 20 | Acceleration/deceleration reference frequency ^① | 50Hz | | 1–400Hz | Set the frequency that will be the basis of acceleration/deceleration time. As acceleration/deceleration time, set the frequency change time from stop to Pr. 20. | 178–184 Input terminal function selection | 6.10.1 |
| 21 | Acceleration/deceleration time increments ^① | 0 | | 0 | Increments: 0.1s Range: 0–3600s | | |
| | | | | 1 | Increments: 0.01 s Range: 0–360 s | | |
| 44 | Second acceleration/deceleration time ^① | FR-E720S-110 or less, FR-E740-095 or less | 5s | 0–3600s/ 0–360s ^② | Set the acceleration/deceleration time when the RT signal is on. | | |
| | | FR-E740-120 and 170 | 10s | | | | |
| | | FR-E740-230 and 300 | 15s | | | | |
| 45 | Second deceleration time ^① | 9999 | | 0–3600s/ 0–360s ^② | Set the deceleration time when the RT signal is on. | | |
| | | | | 9999 | Acceleration time = deceleration time | | |
| 147 | Acceleration/deceleration time switching frequency ^① | 9999 | | 0–400Hz | Frequency when automatically switching to the acceleration/deceleration time of Pr. 44 and Pr. 45. | | |
| | | | | 9999 | No function | | |

① The above parameters can be set when Pr. 160 "User group read selection" = 0.

② Depends on the Pr. 21 "Acceleration/deceleration time increments" setting. The initial value for the setting range is "0 to 3600s" and the setting increments is "0.1s".

Acceleration time setting (Pr. 7, Pr. 20)

Use Pr. 7 "Acceleration time" to set the acceleration time required to reach Pr. 20 "Acceleration/ deceleration reference frequency" from 0Hz.

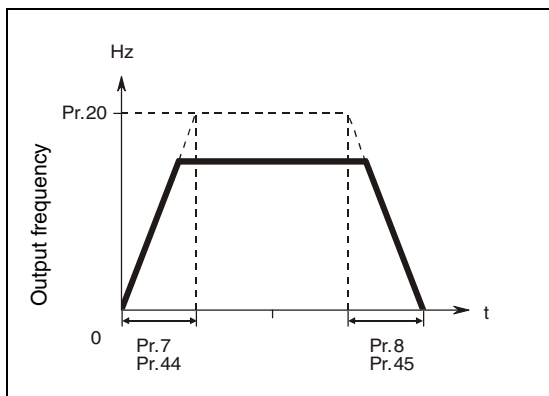

Fig. 6-29:
Acceleration/deceleration time

100006C

Set the acceleration time according to the following formula:

$$\text{Acceleration time setting} = \frac{\text{Pr. 20}}{\text{Maximum operating frequency} - \text{Pr. 13}} \times \text{Acceleration time from stop to maximum operating frequency}$$

Example ▽

When Pr. 20 = 50Hz (initial value), Pr. 13 = 0.5Hz

The acceleration can be made up to the maximum operating frequency of 40Hz in 10s.

$$\text{Pr. 7} = \frac{50\text{Hz}}{40\text{Hz} - 0,5\text{Hz}} \times 10\text{s} = 12.7\text{s}$$

△

Deceleration time setting (Pr. 8, Pr. 20)

Use Pr. 8 "Deceleration time" to set the deceleration time required to reach 0Hz from Pr. 20 "Acceleration/deceleration reference frequency".

Set the deceleration time according to the following formula:

$$\text{Deceleration time setting} = \frac{\text{Pr. 20}}{\text{Maximum operating frequency} - \text{Pr. 10}} \times \text{Deceleration time from maximum operating frequency to stop}$$

Example ▽

When Pr. 20 = 120Hz, Pr. 10 = 3Hz

The deceleration can be made up from the maximum operating frequency of 40Hz to a stop in 10s.

$$\text{Pr. 8} = \frac{120\text{Hz}}{40\text{Hz} - 3\text{Hz}} \times 10\text{s} = 32.4\text{s}$$

△

Change the setting range and increments of the acceleration/deceleration time (Pr. 21)

Use Pr. 21 to set the acceleration/deceleration time and minimum setting range.

Setting "0" (initial value)..... 0 to 3600s (minimum setting increments 0.1s)

Setting "1" 0 to 360s (minimum setting increments 0.01s)



CAUTION:

Changing the Pr. 21 setting changes the acceleration/deceleration setting (Pr. 7, Pr. 8, Pr. 16, Pr. 44, Pr. 45).

(The Pr. 611 "Acceleration time at a restart" setting is not affected.)

Example:

When Pr. 21 = 0, setting "5.0" s in Pr. 7 and "1" in Pr. 21 automatically changes the Pr. 7 setting to "0.5" s.

Set two kinds of acceleration/deceleration times (RT signal, Pr. 44, Pr. 45, Pr. 147)

Pr. 44 and Pr. 45 are valid when the RT signal is on, or the output frequency reaches or exceeds the setting of Pr. 147. Switching the parameter sets allows you to operate motors with different specifications and capabilities with the frequency inverter.

When "9999" is set to Pr. 45, the deceleration time becomes equal to the acceleration time (Pr. 44).

For the RT signal, set "3" in any of Pr. 178 to Pr. 184 "Input terminal function selection" to assign the function.

When RT signal is off, automatic switching of the acceleration/deceleration time is available with Pr. 147.

| Pr. 147 | Acceleration/Deceleration Time | Description |
|-----------------------------------|--|---|
| 9999 (Initial value) | Pr. 7, Pr. 8 | No automatic switching of the acceleration/deceleration time |
| 0.00Hz | Pr. 44, Pr. 45 | Second acceleration/deceleration time from a start |
| 0.00 Hz ≤ Pr. 147 ≤ Set frequency | Output frequency < Pr. 147: Pr. 7, Pr. 8 Pr. 147 ≤ Output frequency: Pr. 44, Pr. 45 | Acceleration/deceleration time automatic switching ① |
| Set frequency < Pr. 147 | Pr. 7, Pr. 8 | No automatic switching, since output frequency will not reach the switching frequency |

Tab. 6-5: Acceleration/deceleration times in dependence on Parameter 147

- ① When the RT signal turns on, the acceleration/deceleration time switches to the second acceleration/deceleration time even when the output frequency is not reached to Pr. 147 setting.

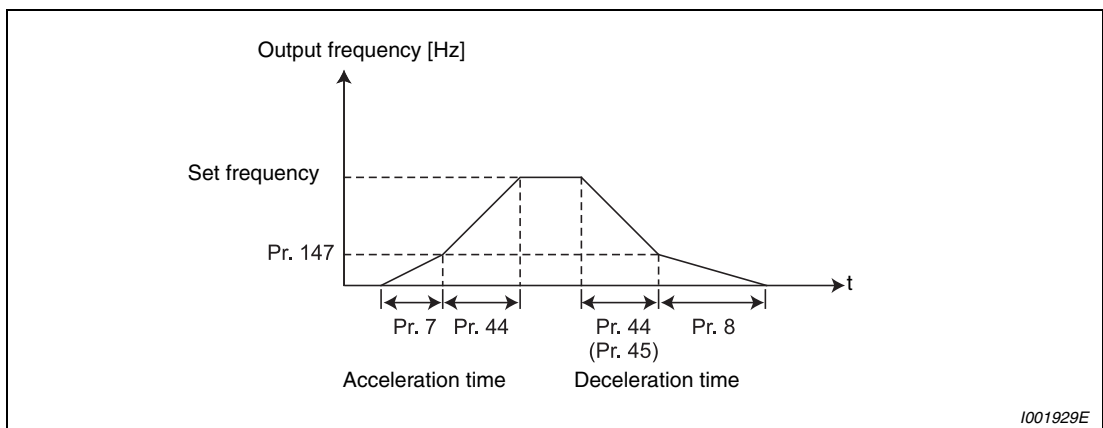

Fig. 6-30: Automatic switching of the acceleration/deceleration time

S-shaped acceleration/deceleration pattern

If a S-shaped acceleration/deceleration pattern A is selected in pr. 29, the set time is the period required to reach the base frequency set in Pr. 3 "Base frequency".

Acceleration/deceleration time formula when the set frequency is the base frequency or higher.

$$t = \frac{4}{9} \times \frac{T}{(\text{Pr. 3})^2} \times f^2 + \frac{5}{9} T$$

T: Acceleration/deceleration time setting value (s)

f: Set frequency (Hz)

NOTE

You will find a detailed description of this parameter in section 6.7.3.

Guideline for acceleration/deceleration time when Pr. 3 Base frequency = 50Hz (0Hz to set frequency).

| Acceleration/deceleration time [s] | Frequency Setting [Hz] | | | |
|------------------------------------|------------------------|-----|-----|-----|
| | 50 | 120 | 200 | 400 |
| 5 | 5 | 16 | 38 | 145 |
| 15 | 15 | 47 | 115 | 435 |

Tab. 6-6: Acceleration/deceleration time at a base frequency of 50Hz

NOTES

Changing terminal assignment may affect the other functions. Make setting after confirming the function of each terminal. (Refer to section 6.10.3.)

If the Pr. 20 setting is changed, the Pr. 125 and Pr. 126 (frequency setting signal gain frequency) settings do not change. Set Pr. 125 and Pr. 126 to adjust the gains.

When the Pr. 7, Pr. 8, Pr. 44 and Pr. 45 settings are 0.03s or less, the acceleration/deceleration time is 0.04s. At that time, set Pr. 20 to "120Hz" or less.

If the acceleration/deceleration time is set, the actual motor acceleration/deceleration time cannot be made shorter than the shortest acceleration/deceleration time determined by the mechanical system J (inertia moment) and motor torque.

6.7.2 Starting frequency and start-time hold function

You can set the starting frequency and hold the set starting frequency for a certain period of time. Set these functions when you need the starting torque or want to smooth motor drive at a start.

| Pr. No. | Name | Initial Value | Setting Range | Description | Parameters referred to | Refer to Section |
|---------|-----------------------|---------------|---------------|--|------------------------|------------------|
| 13 | Starting frequency | 0.5Hz | 0–60Hz | Frequency at start can be set in the range 0 to 60Hz. You can set the starting frequency at which the start signal is turned on. | 2 Minimum frequency | 6.4.1 |
| | | | | | | |
| 571 | Holding time at start | 9999 | 0.0–10.0s | Set the holding time of Pr. 13 "Starting frequency". | | |
| | | | 9999 | Holding function at a start is invalid | | |

The above parameters can be set when Pr. 160 "User group read selection" = 0.

Starting frequency setting (Pr. 13)

The motor is started with the specified start frequency as soon as the frequency inverter receives a start signal and a frequency setting that is greater than or equal to the preset starting frequency.

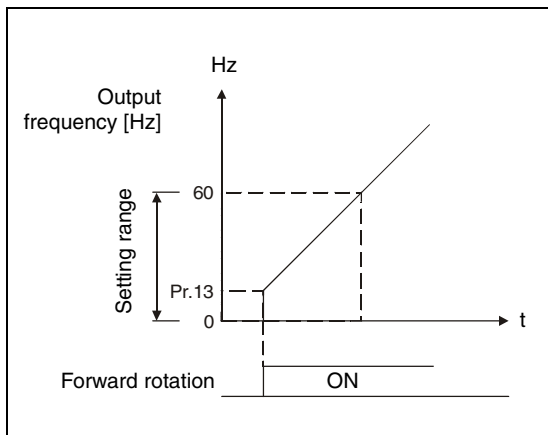

Fig. 6-31:
Starting frequency parameter

1000008C

NOTE

The inverter will not start if the frequency setting signal is less than the value set in Pr. 13.

Example ▽

When 5Hz is set in Pr. 13, the motor will not start running until the frequency setting signal reaches 5Hz.

△



WARNING:

Note that when Pr. 13 is set to any value lower than Pr. 2 "Minimum frequency", simply turning on the start signal will run the motor at the preset frequency even if the command frequency is not input.

Start-time hold function (Pr. 571)

This function holds the time set in Pr. 571 and the output frequency set in Pr. 13 "Starting frequency".

This function performs initial excitation to smooth the motor drive at a start.

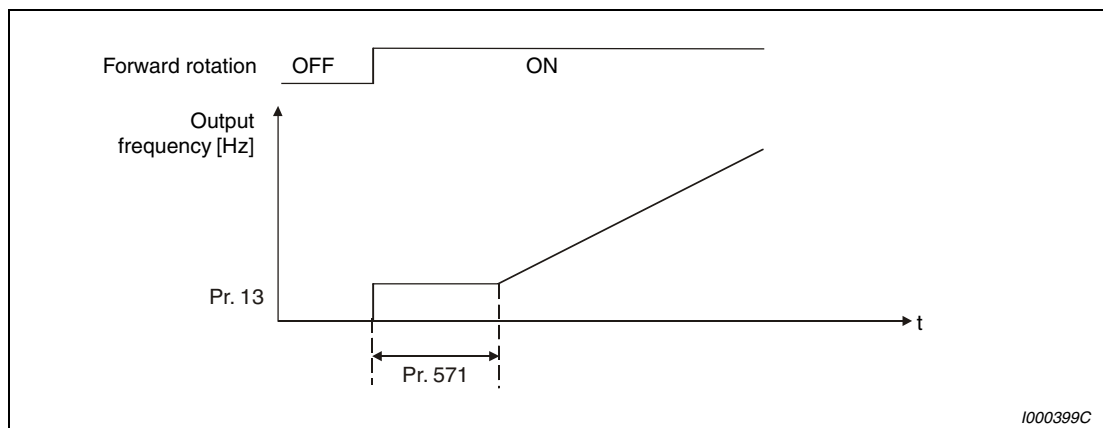

Fig. 6-32: Holding time at start

NOTES

- When the start signal was turned off during start-time hold, deceleration is started at that point.
- At switching between forward rotation and reverse rotation, the starting frequency is valid but the start-time hold function is invalid.
- When Pr. 13 = 0Hz, the starting frequency is held at 0.01Hz.

6.7.3 Acceleration and deceleration pattern (Pr. 29)

You can set the acceleration/deceleration pattern suitable for application.

| Pr. No. | Name | Initial Value | Setting Range | Description | Parameters referred to | Refer to Section |
|---------|---|---------------|---------------|---------------------------------------|--|----------------------------------|
| 29 | Acceleration/deceleration pattern selection | 0 | 0 | Linear acceleration/deceleration | 3 Base frequency 7 Acceleration time 8 Deceleration time 20 Acceleration/deceleration reference frequency | 6.5.1 6.7.1 6.7.1 6.7.1 |
| | | | 1 | S-pattern acceleration/deceleration A | | |
| | | | 2 | S-pattern acceleration/deceleration B | | |

The above parameters can be set when Pr. 160 "User group read selection" = 0.

Linear acceleration/deceleration (Pr. 29 = 0, initial value)

For the inverter operation, the output frequency is made to change linearly (linear acceleration/deceleration) to prevent the motor and inverter from excessive stress to reach the set frequency during acceleration, deceleration, etc. when frequency changes. Linear acceleration/deceleration has a uniform frequency/time slope (refer to Fig. 6-33).

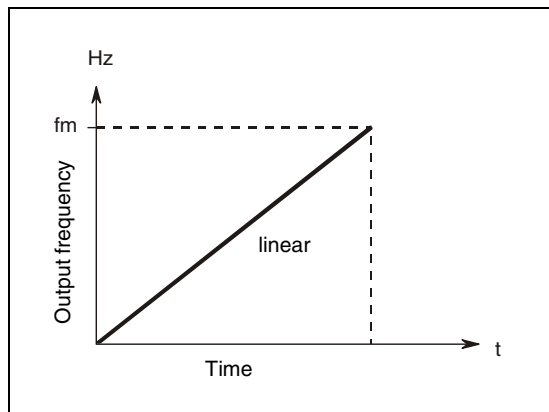

Fig. 6-33:
Characteristic for parameter 29 = 0

1000015C

S-pattern acceleration/deceleration A (Pr. 29 = 1)

For machine tool spindle applications, etc.
 Used when acceleration/deceleration must be made in a short time to a high-speed range of not lower than base frequency. In this acceleration/deceleration pattern, Pr. 3 "Base frequency" (fb) is the inflection point of the S-pattern (refer to Fig. 6-34) and you can set the acceleration/deceleration time appropriate for motor torque reduction in a constant-output operation region of base frequency or higher.

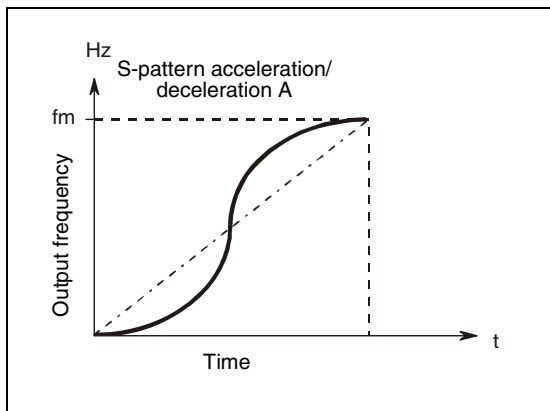

Fig. 6-34:
 Characteristic for parameter 29 = 1

1000016C

S-pattern acceleration/deceleration B (Pr. 29 = 2)

When a setting of "2" is entered frequency changes are executed with an S-pattern. For example, if a drive is accelerated from 0 to 30Hz and then re-accelerated to 50Hz then each acceleration sequence (i.e. the first sequence from 0 to 30Hz and the second from 30Hz to 50Hz) will be executed with an S-pattern. The time for the S-pattern is not longer than that for linear acceleration (refer to Fig. 6-35). This prevents jolts in drive operation, for example for conveyor belt and positioning drive systems.

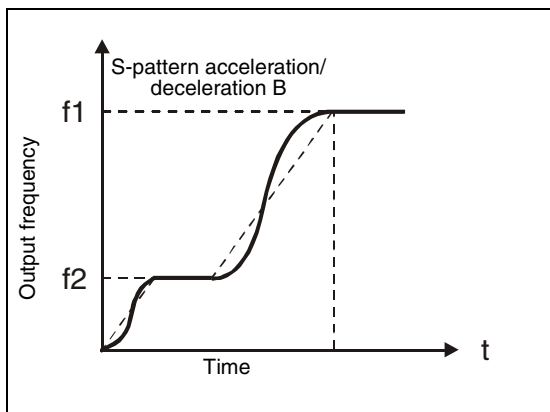

Fig. 6-35:
 Characteristic for parameter 29 = 2

1000017C

NOTE

As the acceleration/deceleration time of S-pattern acceleration/deceleration A, set the time taken until Pr. 3 "Base frequency" is reached, not Pr. 20 "Acceleration/deceleration reference frequency".

6.7.4 Shortest acceleration/deceleration (automatic acceleration/deceleration) (Pr. 61 to Pr. 63, Pr. 292, Pr. 293)

The inverter operates in the same conditions as when appropriate values are set in each parameter even if acceleration/deceleration time and V/f pattern are not set. This function is useful when you just want to operate, etc. without fine parameter setting.

| Pr. No. | Name | Initial Value | Setting Range | Description | Parameters referred to | Refer to Section |
|------------|--|---------------|---------------|--|---|----------------------------------|
| 61 | Reference current | 9999 | 0–500A | Set the reference current during shortest acceleration/deceleration. | 0 Torque boost 7 Acceleration time 8 Deceleration time 22 Stall prevention operation level | 6.3.1 6.7.1 6.7.1 6.3.5 |
| | | | 9999 | Rated inverter output current value is reference | | |
| 62 | Reference value at acceleration | 9999 | 0–200% | Set the limit value during shortest acceleration. | | |
| | | | 9999 | 150% is a limit value | | |
| 63 | Reference value at deceleration | 9999 | 0–200% | Set the limit value during shortest deceleration. | | |
| | | | 9999 | 150% is a limit value | | |
| 292 | Automatic acceleration/deceleration | 0 | 0 | Normal mode | | |
| | | | 1 | Shortest acceleration/deceleration (without brake) | | |
| | | | 11 | Shortest acceleration/deceleration (with brake) | | |
| | | | 7/8 | Brake sequence mode 1, 2 (Refer to section 6.9.5.) | | |
| 293 | Acceleration/deceleration separate selection | 0 | 0 | Both acceleration and deceleration are made in the shortest acceleration/deceleration mode | | |
| | | | 1 | Only acceleration is made in the shortest acceleration/deceleration mode | | |
| | | | 2 | Only deceleration is made in the shortest acceleration/deceleration mode | | |

The above parameters can be set when Pr. 160 "User group read selection" = 0.

Shortest acceleration/deceleration mode (Pr. 292 = 1, 11, Pr. 293)

- Set when you want to accelerate/decelerate the motor for the shortest time. It is desired to make acceleration/deceleration in a shorter time for a machine tool etc. but the design values of machine constants are unknown.
- Acceleration/deceleration speed is automatically adjusted at a start of acceleration/deceleration from the value of the setting value of Pr. 7 "Acceleration time" and Pr. 8 "Deceleration time" so that acceleration/deceleration is made with the maximum torque the inverter can output. (The setting values of Pr. 7 and Pr. 8 are not changed.)
- Either acceleration or deceleration can be made in the shortest time using Pr. 293 "Acceleration/deceleration separate selection". When the setting value is "0" (initial value), both acceleration and deceleration can be made in the shortest time.
- Set "11" when an optional high-duty brake resistor or brake unit is connected. Deceleration time can be further shortened.
- When the shortest/acceleration mode is selected, the stall prevention operation level during acceleration/deceleration from the value of becomes 150% (adjustable using Pr. 61 to Pr. 63). Setting of Pr. 22 "Stall prevention operation level" is used only during a constant speed operation.
- It is inappropriate to use for the following applications.
 - Machine with a large inertia such as a fan (more than 10 times). Since stall prevention operation will be activated for a long time, this type of machine may be brought to an alarm stop due to motor overloading, etc.
 - It is desired to always perform operation with a constant acceleration/deceleration time.

NOTES

Even if automatic acceleration/deceleration mode has been selected, inputting the jog signal (jog operation) or RT signal (second function selection) during an inverter stop will switch to the normal operation and give priority to jog operation or second function selection. Note that JOG and RT signal input is invalid even if JOG signal and RT signal are input during operation in automatic acceleration/deceleration mode.

Since acceleration/deceleration is made with the stall prevention operation being activated, the acceleration/deceleration speed always varies according to the load conditions.

Note that when proper values are set in Pr. 7 and Pr. 8, acceleration/deceleration time may be shorter than selecting shortest acceleration/deceleration mode.

Adjustment of shortest acceleration/deceleration mode (Pr. 61 to Pr. 63)

By setting the adjustment parameters Pr. 61 to Pr. 63, the application range can be made wider.

| Pr. No. | Name | Setting Range | Description |
|---------|---------------------------------|-------------------------|---|
| 61 | Reference current | 0–500A | For example, when the motor and inverter are different in capacity, set the rated motor current value. Set reference current (A) of the stall prevention operation level during acceleration/deceleration. |
| | | 9999 (initial value) | The rated inverter current is defined as reference. |
| 62 | Reference value at acceleration | 0–200% | Set when it is desired to change the reference level of acceleration and deceleration. Set the stall prevention operation level (ratio to the current value of Pr. 61) during acceleration/deceleration. |
| 63 | Reference value at deceleration | 9999 (initial value) | The 150% value during shortest acceleration/deceleration is judged as the stall prevention operation level. |

Tab. 6-7: *Adjustment parameter setting*

NOTE

Since the Pr. 61 to Pr. 63 settings automatically return to the initial value (9999) if the Pr. 292 setting is changed, set Pr. 292 first when you need to set Pr. 61 to Pr. 63.

6.8 Selection and protection of a motor

| Purpose | Parameters that must be set | | Refer to Section |
|--|------------------------------|---|------------------|
| Motor protection from overheat | Electronic thermal O/L relay | Pr. 9, Pr. 51 | 6.8.1 |
| Use the constant torque motor | Applied motor | Pr. 71 | 6.8.2 |
| The motor performance can be maximized for operation in magnetic flux vector control method. | Offline auto tuning | Pr. 71, Pr. 80–Pr. 84, Pr. 90–Pr. 94, Pr. 96, Pr. 859 | 6.8.3 |

6.8.1 Motor overheat protection (Electronic thermal O/L relay) (Pr. 9, Pr. 51)

The FR-E700 EC frequency inverters have an internal electronic motor protection function that monitors the motor frequency and motor current. Overload conditions are identified and the motor protection function is triggered on the basis of these two factors, in combination with the rated motor current. The electronic motor protection function is primarily for protection against overheating at intermediate speeds and high motor torques. The reduced cooling performance of the motor fan under these conditions is also taken into account.

| Pr. No. | Name | Initial Value | Setting Range | Description | Parameters referred to | Refer to Section |
|---------|---|---------------------------------|---------------|--|--|------------------|
| 9 | Electronic thermal O/L relay | Rated inverter output current ① | 0–500A | Set the rated motor current. | 71 Applied motor | 6.8.2 |
| | | | | Made valid when the RT signal is on. Set the rated motor current. | 72 PWM frequency selection | 6.15.1 |
| 51 | Second electronic thermal O/L relay ② ③ | 9999 | 0–500A | Second electronic thermal O/L relay invalid | 178–184 Input terminal function selection | 6.10.1 |
| | | | | | 190–192 Output terminal function selection | 6.10.5 |

- ① The initial value of the FR-E720S-050 or less and FR-E740-026 or less is set to 85% of the rated inverter current.
- ② The above parameters can be set when Pr. 160 "User group read selection" = 0.
- ③ When parameter is read using the FR-PU04, a parameter name different from an actual parameter is displayed.

Electronic thermal O/L relay (Pr. 9)

Set the rated current [A] of the motor in Pr. 9. (When the power supply specification is 400V/440V 60Hz, set the 1.1 times the rated motor current.)

Set "0" to Pr. 9 when you do not want to activate the electronic thermal relay function, e.g. when using an external thermal relay with the motor. (Note that the output transistor protection of the inverter functions (E.THT).)

When using the Mitsubishi constant-torque motor set "1, 13 to 16, 50, 53 or 54" to Pr. 71. (This provides a 100% continuous torque characteristic in the low-speed range.) After this set the rated current of the motor to Pr. 9.

The figure below shows the electronic thermal relay function operation characteristic. The region on the right of the characteristic curve is the operation region. The region on the left of the characteristic curve is the non-operation region.

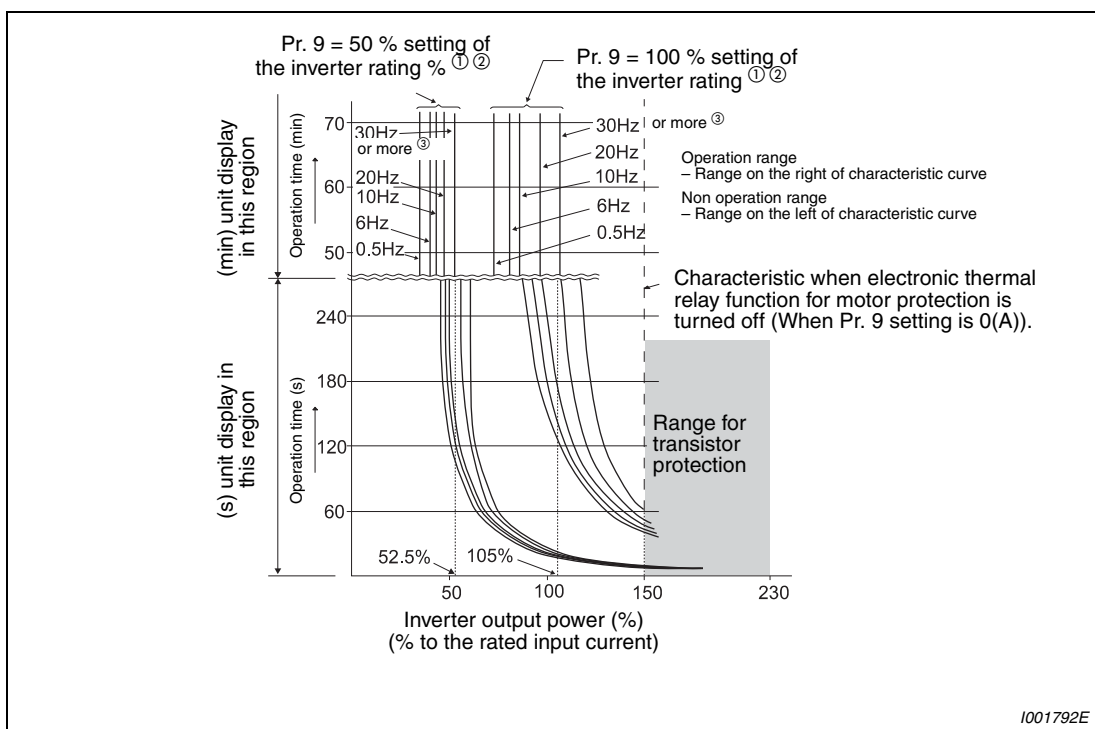

Fig. 6-36: Electronic thermal relay function operation characteristic

- ① When a value 50% of the inverter rated output current (current value) is set to Pr. 9.
- ② The % value denotes the percentage to the inverter rated output current. It is not the percentage to the motor rated current.
- ③ When you set the electronic thermal relay function dedicated to the Mitsubishi constant-torque motor, this characteristic curve applies to operation at 6Hz or higher.

NOTES

Fault by electronic thermal relay function is reset by inverter power reset and reset signal input. Avoid unnecessary reset and power-off.

When multiple motors are operated by a single inverter, protection cannot be provided by the electronic thermal relay function. Install an external thermal relay to each motor.

When the difference between the inverter and motor capacities is large and the setting is small, the protective characteristics of the electronic thermal relay function will be deteriorated. In this case, use an external thermal relay.

A special motor cannot be protected by the electronic thermal relay function. Use the external thermal relay.

The operation time of the transistor protection thermal relay shortens when the Pr. 72 "PWM frequency selection" setting increases.

Electronic thermal relay does not work when 5 % or less of inverter rated current is set to electronic thermal relay setting.

Set two different electronic thermal O/L relays (Pr. 51)

Use this function when running two motors of different rated currents individually by a single inverter. (When running two motors together, use external thermal relays.)

Set the rated current of the second motor to Pr. 51. When the RT signal is on, thermal protection is provided based on the Pr. 51 setting.

For the terminal used for RT signal input, set "3" in any of Pr. 178 to Pr. 184 "Input terminal function selection" to assign the function.

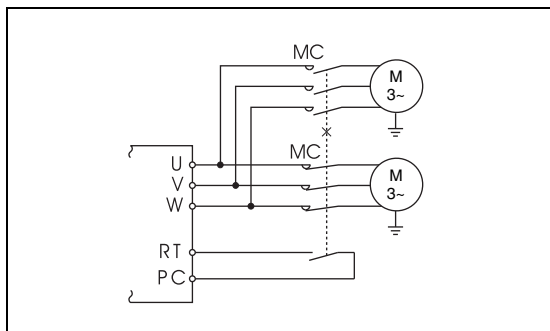

Fig. 6-37:
Running two motors by a single inverter

1001137C

| Pr. 450 Second applied motor | Pr. 9 Electronic thermal O/L relay | Pr. 51 Second electronic thermal O/L relay | RT = OFF | | RT = ON | |
|------------------------------------|--|--|----------|----------|----------|----------|
| | | | 1. motor | 2. motor | 1. motor | 2. motor |
| 9999 | 0 | 9999 | — | — | — | — |
| | | 0 | — | — | — | — |
| | | 0.01–500 | — | △ | — | ● |
| 9999 | ≠ 0 | 9999 | ● | — | ● | — |
| | | 0 | ● | — | △ | — |
| | | 0.01–500 | ● | △ | △ | ● |
| ≠ 9999 | 0 | 9999 | — | — | — | — |
| | | 0 | — | — | — | — |
| | | 0.01–500 | — | △ | — | ● |
| ≠ 9999 | ≠ 0 | 9999 | ● | △ | △ | ● |
| | | 0 | ● | — | △ | — |
| | | 0.01–500 (0.1–3600) | ● | △ | △ | ● |

Tab. 6-8: Switching the electronic thermal O/L relay

- Output current value is used to perform integration processing.
- △ Output current is assumed as 0A to perform integration processing. (cooling processing)
- Electronic thermal relay function is not activated.

NOTE

The RT signal acts as the second function selection signal and makes the other second functions valid. (Refer to section 6.10.3.)

Electronic thermal relay function prealarm (TH) and alarm signal (THP signal)

The alarm signal (THP) is output and electronic thermal relay function prealarm (TH) is displayed when the electronic thermal O/L relay cumulative value reaches 85% of the level set in Pr. 9 or Pr. 51. If it reaches 100% of the Pr. 9 "Electronic thermal O/L relay setting", a motor overload trip (E.THM) occurs.

NOTE The prealarm signal "THP" is also issued as soon as the thermal load of the IGBT output stages of the frequency inverter is 85%. If the load rises further up to 100%, then the thermal overload protection of the frequency inverter responds and the "E.THT" error message is shown.

For the terminal used for the THP signal output, assign the function by setting "8 (positive logic) or 108 (negative logic)" in any of Pr. 190 to Pr. 192 "Output terminal function selection".

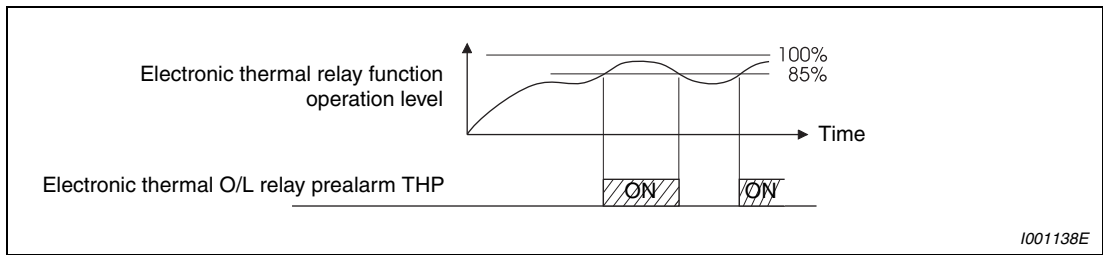

Fig. 6-38: Prealarm signal output

NOTE Changing the terminal assignment using Pr. 190 to Pr. 192 "Output terminal function selection" may affect the other functions. Make setting after confirming the function of each terminal.

External thermal relay input (OH signal)

To protect the motor against overheat, use the OH signal (refer to Fig. 6-39) when using an external thermal relay or the built-in thermal protector of the motor.

When the thermal relay operates, the inverter trips and outputs the fault signal (E.OHT).

For the terminal used for OH signal input, assign the function by setting "7" to any of Pr. 178 to Pr. 184 "Input terminal function selection".

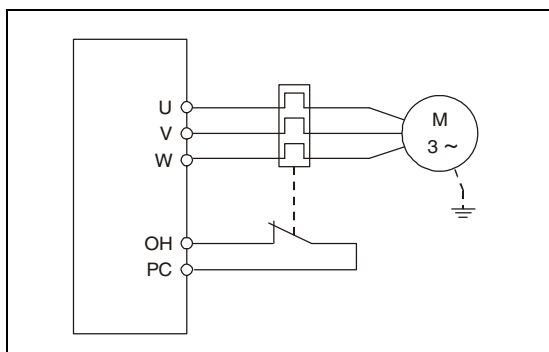

Fig. 6-39: Connection of an external thermal relay

NOTE Changing the terminal assignment using Pr. 178 to Pr. 184 "Input terminal function selection" may affect the other functions. Make setting after confirming the function of each terminal.

6.8.2 Applied motor (Pr. 71, Pr. 450)

Setting of the used motor selects the thermal characteristic appropriate for the motor.

Setting is required to use a constant-torque motor. Thermal characteristic of the electronic thermal relay function suitable for the motor is set.

When general-purpose magnetic flux vector or advanced magnetic flux vector control is selected, the motor constants (SF-JR, SF-HR, SF-JRCA, SF-HRCA, etc.) necessary for control are selected as well.

| Pr. No. | Name | Initial Value | Setting Range | Description | Parameters referred to | Refer to Section |
|------------|----------------------|---------------|---|--|--|----------------------------------|
| 71 | Applied motor | 0 | 0/1-3-6/ 13-16/23/24/ 40/43/44/50/ 53/54 | Selecting the standard motor or constant-torque motor sets the corresponding motor thermal characteristic. | 0 Torque boost 12 DC injection brake operation voltage 80 Motor capacity 81 Number of motor poles | 6.3.1 6.9.1 6.8.3 6.8.3 |
| 450 | Second applied motor | 9999 | 0/1 | Set when using the second motor. | 82-84 Motor constants | 6.8.3 |
| | | | 9999 | Second motor is invalid (thermal characteristic of the first motor (Pr. 71)) | 90-94 96 800 Control method selection | 6.2.1 |

Set the motor to be used

Refer to the following list and set this parameter according to the motor used.

| Pr. 71 | Pr. 450 | Thermal Characteristic of the Electronic Thermal Relay Function | | Motor | |
|----------------------|-------------------------|--|---|--|---------------------------------|
| | | | | Standard (SF-JR, etc.) | Constant torque (SF-JRCA, etc.) |
| 0 (initial value) | | Thermal characteristics of a standard motor | | ✓ | — |
| 1 | | Thermal characteristics of the Mitsubishi constant-torque motor | | | ✓ |
| 40 | — | Thermal characteristic of Mitsubishi high efficiency motor (SF-HR) | | ✓ ^① | |
| 50 | — | Thermal characteristic of Mitsubishi constant torque motor (SF-HRCA) | | | ✓ ^② |
| 3 | — | Standard motor | Select "Offline auto tuning setting" | ✓ | |
| 13 | — | Constant-torque motor | | | ✓ |
| 23 | — | Mitsubishi standard motor (SF-JR 4P 1.5kW or less) | | ✓ | |
| 43 | — | Mitsubishi high efficiency motor (SF-HR) | | ✓ ^① | |
| 53 | — | Mitsubishi constant-torque motor (SF-HRCA) | | | ✓ ^② |
| 4 | — | Standard motor | Auto tuning data can be read, changed, and set. | ✓ | |
| 14 | — | Constant-torque motor | | | ✓ |
| 24 | — | Mitsubishi standard motor (SF-JR 4P 1.5kW or less) | | ✓ | |
| 44 | — | Mitsubishi high efficiency motor (SF-HR) | | ✓ ^① | |
| 54 | — | Mitsubishi constant-torque motor (SF-HRCA) | | | ✓ ^② |
| 5 | — | Standard motor | Star connection | Direct input of motor constants is enabled | ✓ |
| 15 | — | Constant-torque motor | | | |
| 6 | — | Standard motor | Delta connection | | ✓ |
| 16 | — | Constant-torque motor | | | |
| — | 9999 (initial value) | Without second applied motor | | | |

Tab. 6-9: Setting of parameter Pr. 71 and Pr. 450

- ① Motor constants of Mitsubishi high efficiency motor SF-HR.
- ② Motor constants of Mitsubishi constant-torque motor SF-HRCA.

NOTE

For the FR-E740-120 and 170, the Pr. 0 "Torque boost" and Pr. 12 "DC injection brake operation voltage" settings are automatically changed according to the Pr. 71 setting as follows.

| Pr. 71 | 0, 3–6, 23, 24, 40, 43, 44 | 1, 13–16, 50, 53, 54 |
|--------|----------------------------|----------------------|
| Pr. 0 | 3% | 2% |
| Pr. 12 | 4% | 2% |

Tab. 6-10: Changes of parameter 0 and 12 related to parameter 71

Use two motors (Pr. 450)

- Set Pr. 450 "Second applied motor" to use two different motors with one inverter.
- When "9999" (initial value) is set, no function is selected.
- When a value other than "9999" is set in Pr. 450, the second motor is valid when the RT signal turns on.
- For the RT signal, set "3" in any of Pr. 178 to Pr. 184 "Input terminal function selection" to assign the function.

NOTES

The RT signal acts as the second function selection signal and makes the other second functions valid. (Refer to section 6.10.3.)

Changing the terminal assignment using Pr. 178 to Pr. 184 "Input terminal function selection" may affect other functions. Make setting after confirming the function of each terminal.

**CAUTION:**

- *Set this parameter correctly according to the motor used. Incorrect setting may cause the motor to overheat and burn.*
- *Set the electronic thermal relay function to the thermal characteristic for the constant-torque motor when using a geared motor (GM-G, GM-D, GM-SY, GM-HY2 series) to perform advanced magnetic flux vector control or general-purpose magnetic-flux vector control.*

6.8.3 To exhibit the best performance of the motor performance (offline auto tuning) (Pr. 71, Pr. 80 to Pr. 84, Pr. 90 to Pr. 94, Pr. 96, Pr. 859)

The motor performance can be maximized with offline auto tuning.

What is offline auto tuning?

- When performing advanced magnetic flux vector control or general-purpose magnetic flux vector control, the motor can be run with the optimum operating characteristics by automatically measuring the motor constants (offline autotuning) even when each motor constants differs, other manufacturer's motor is used, or the wiring length is long.

| Pr. No. | Name | Initial Value | | Setting Range | Description | Parameters referred to | Refer to Section |
|---------|----------------------------|---------------|------|---------------------------------------|--|--|-------------------------|
| 71 | Applied motor | 0 | | 0/1-3-6/13-16/23/24/40/43/44/50/53/54 | By selecting a standard motor or constant-torque motor, thermal characteristic and motor constants of each motor are set. | 7 Acceleration time 8 Deceleration time 9 Electronic thermal O/L relay | 6.7.1 6.7.1 6.8.1 |
| | | | | 0.1-15kW | Applied motor capacity. | | |
| 80 | Motor capacity | 9999 | | 9999 | V/f control | 80 Motor capacity | 6.2.1 |
| | | | | 2/4/6/8/10 | Number of motor poles. | 81 Number of motor poles | 6.2.1 |
| 81 | Number of motor poles | 9999 | | 9999 | V/f control | 156 Stall prevention operation selection | 6.3.5 |
| | | | | 0-500A | Tuning data (The value measured by offline auto tuning is automatically set.) | 178-184 Input terminal function selection | 6.10.1 |
| 82 | Motor excitation current | 9999 | | 9999 | Uses the Mitsubishi motor (SF-JR, SF-HR, SF-JRCA, SF-HRCA) constants. | 190-192 Output terminal function selection | 6.10.5 |
| | | | | 0-1000 V | Rated motor voltage (V). | 800 Control method selection | 6.2.1 |
| 83 | Motor rated voltage | 200V class | 200V | 0-1000 V | Rated motor voltage (V). | | |
| | | 400V class | 400V | | | | |
| 84 | Rated motor frequency | 50Hz | | 10-120Hz | Rated motor frequency (Hz). | | |
| 90 | Motor constant (R1) | 9999 | | 0-50Ω/9999 | Tuning data (The value measured by offline auto tuning is automatically set.) 9999: Uses the Mitsubishi motor (SF-JR, SF-HR, SF-JRCA, SF-HRCA) constants. | | |
| 91 | Motor constant (R2) | 9999 | | 0-50Ω/9999 | | | |
| 92 | Motor constant (L1) | 9999 | | 0-1000mH/9999 | | | |
| 93 | Motor constant (L2) | 9999 | | 0-1000mH/9999 | | | |
| 94 | Motor constant (X) | 9999 | | 0-100%/9999 | | | |
| 96 | Auto tuning setting/status | 0 | | 0 | | Offline auto tuning is not performed | |
| | | | | 1 | For advanced magnetic flux vector control Offline auto tuning is performed without motor running (all motor constants). | | |
| | | | | 11 | For general-purpose magnetic flux vector control Offline auto tuning is performed without motor running. (motor constant (R1) only) | | |
| | | | | 21 | Offline auto tuning for V/f control (automatic restart after instantaneous power failure (with frequency search)) | | |
| 859 | Torque current | 9999 | | 0-500A | Tuning data (The value measured by offline auto tuning is automatically set.) | | |
| | | | | 9999 | Uses the Mitsubishi motor (SF-JR, SF-HR, SF-JRCA, SF-HRCA) constants. | | |

The above parameters can be set when Pr. 160 "User group read selection" = 0.

The setting range and increments of Pr. 82, Pr. 90 to Pr. 94 and Pr. 859 changes according to the setting value of Pr. 71 and Pr. 96.

| Applied Motor | | Internal Stored Value ^① | | Direct Input Value ^② | | Auto Tuning Measured Value ^③ | |
|---------------|--------------------------|------------------------------------|--------------------|---------------------------------|--------------------|---|--------------------|
| Pr. | Function Name | Setting Range | Setting Increments | Setting Range | Setting Increments | Setting Range | Setting Increments |
| 82 | Motor excitation current | 0–500A, 9999 | 0.01A | 0–500A, 9999 | 0.01A | 0–****, 9999 | 1 |
| 90 | Motor constant R1 | 0–50Ω, 9999 | 0.001Ω | 0–50Ω, 9999 | 0.001Ω | 0–****, 9999 | 1 |
| 91 | Motor constant R2 | 0–50Ω, 9999 | 0.001Ω | 0–50Ω, 9999 | 0.001Ω | 0–****, 9999 | 1 |
| 92 | Motor constant L1 | 0–1000mH, 9999 | 0.1mH | 0–50Ω, 9999 | 0.001Ω | 0–****, 9999 | 1 |
| 93 | Motor constant L2 | 0–1000mH, 9999 | 0.1mH | 0–50Ω, 9999 | 0.001Ω | 0–****, 9999 | 1 |
| 94 | Motor constant X | 0–100%, 9999 | 0.1% | 0–500Ω, 9999 | 0.01Ω | 0–****, 9999 | 1 |
| 859 | Torque current | 0–500A, 9999 | 0.01A | 0–500A, 9999 | 0.01A | 0–****, 9999 | 1 |

Tab. 6-11: Parameter setting ranges

- ① When Pr. 71 = "0, 1, 40 or 50", or setting value of Pr. 96 read after performing offline auto tuning is not "3, 13, 23".
 - ② When Pr. 71 = "5, 6, 15, or 16"
 - ③ When Pr. 71 = "3, 13, 23, 43 or 53" and setting value of Pr. 96 read after performing offline auto tuning is "3, 13, 23". Or when Pr. 71 = "4, 14, 24, 44 or 54".
- This function is made valid only when a value other than "9999" is set in Pr. 80 and Pr. 81 and advanced magnetic flux vector control or general-purpose magnetic flux vector control is selected.
 - You can copy the offline auto tuning data (motor constants) to another inverter with the PU (FR-PU07).
 - Even when motors (other manufacturer's motor, SF-JRC, etc.) other than Mitsubishi standard motor, high efficiency motor (SF-JR, SF-HR 0.2kW or more), and Mitsubishi constant-torque motor (SF-JRCA four-pole, SF-HRCA 0.4kW to 15kW) are used or the wiring length is long, using the offline auto tuning function runs the motor with the optimum operating characteristics.
 - Tuning is enabled even when a load is connected to the motor.



CAUTION:

As the motor may run slightly, fix the motor securely with a mechanical brake or make sure that there will be no problem in safety if the motor runs (caution is required especially in elevator). Note that tuning performance is unaffected even if the motor runs slightly.

- Reading/writing/copy of motor constants tuned by offline auto tuning are enabled.
- The offline auto tuning status can be monitored with the operation panel and PU (FR-PU04/FR-PU07).
- Do not connect a surge voltage suppression filter (FFR-DT) between the inverter and motor.

Before performing offline auto tuning

Check the following before performing offline auto tuning.

- Make sure advanced magnetic flux vector control or general-purpose magnetic flux vector control (Pr. 80, Pr. 81) is selected. (Tuning can be performed even under V/f control selected by turning on X18.)
- A motor should be connected. Note that the motor should be at a stop at a tuning start.
- The motor capacity should be equal to or one rank lower than the inverter capacity.
- The maximum frequency is 120Hz.
- A high-slip motor, high-speed motor and special motor cannot be tuned.



CAUTION:

As the motor may run slightly, fix the motor securely with a mechanical brake or make sure that there will be no problem in safety if the motor runs (caution is required especially in elevator). Note that tuning performance is unaffected even if the motor runs slightly.

- Offline auto tuning will not be performed properly if it is performed with a surge voltage suppression filter (FFR-DT) connected between the inverter and motor. Remove it before starting tuning.

Setting

- Select advanced magnetic flux vector control (refer to section 6.3.2) or general-purpose magnetic flux vector control (refer to section 6.3.3).
- Set "1" or "11" in Pr. 96 "Auto tuning setting/status".
 - When the setting is "1": Tune all motor constants without running the motor. When performing advanced magnetic flux vector control, set "1" to perform tuning. It takes approximately 25 to 75s (depending on the inverter inverter capacity and motor type) until tuning is completed. (Excitation noise is produced during tuning.)
 - When the setting is "11": Tune motor constants (R1) only without running the motor. When performing general-purpose magnetic flux vector control, set "11" to perform tuning. It takes approximately 9s until tuning is completed.
- Set the rated motor current (initial value is rated inverter current) in Pr. 9 "Electronic thermal O/L relay". (Refer to section 6.8.)
- Set the rated voltage of motor (initial value is 400V) in Pr. 83 "Motor rated voltage" and rated motor frequency (initial value is 50Hz) in Pr. 84 "Rated motor frequency".
- Set Pr. 71 "Applied motor" according to the motor used.

| Motor | | Pr. 71 ① |
|---|-------------------------|----------|
| Mitsubishi standard motor Mitsubishi high efficiency motor | SF-JR | 3 |
| | SF-JR 4P-1.5 kW or less | 23 |
| | SF-HR | 43 |
| | Others | 3 |
| Mitsubishi constant-torque motor | SF-JRCA 4P | 13 |
| | SF-HRCA | 53 |
| | Others (SF-JRC, etc.) | 13 |
| Other manufacturer's standard motor | — | 3 |
| Other manufacturer's constant-torque motor | — | 13 |

Tab. 6-12: Motor selection

① Refer to section 6.8.2, for other settings of Pr. 71.

Execution of tuning

**CAUTION:**

Before performing tuning, check the monitor display of the operation panel or parameter unit (FR-PU04/FR-PU07) if the inverter is in the status for tuning (refer to Tab. 6-13). When the start command is turned on under V/f control, the motor starts.

When performing tuning or PU operation, press the RUN key of the operation panel or the FWD or REV key of the parameter unit (FR-PU04/FR-PU07).

For external operation, turn on the run command (STF signal or STR signal). Tuning starts.

NOTES

To force tuning to end, use the MRS or RES signal or press the STOP/RESET key of the operation panel. (Turning the start signal (STF signal or STR signal) off also ends tuning.)

During offline auto tuning, only the following I/O signals are valid: (initial value)

- Input terminal:
MRS, RES, STF, STR
- Output terminal:
RUN, AM, A, B, C

Note that the progress status of offline auto tuning is output in eight steps from AM when speed and output frequency are selected.

Since the RUN signal turns on when tuning is started, caution is required especially when a sequence which releases a mechanical brake by the RUN signal has been designed.

When executing offline auto tuning, input the run command after switching on the main circuit power (R/L1, S/L2, T/L3) of the inverter.

Do not perform ON/OFF switching of the second function selection signal (RT) during execution of offline autotuning. Auto tuning is not executed properly.

Do not connect a surge voltage suppression filter (FFR-DT) between the inverter and motor.

Display during tuning

Monitor is displayed on the operation panel and parameter unit (FR-PU04/FR-PU07) during tuning as below.

| | Parameter Unit (FR-PU04/FR-PU07) Display | | Operation Panel Indication | |
|--|--|----|----------------------------|----|
| | 1 | 11 | 1 | 11 |
| Setting | | | | |
| Tuning in progress | | | | |
| Normal end | | | | |
| Error end (when inverter protective function operation is activated) | | | | |

Tab. 6-13: Display during tuning (monitor display)

| Offline Auto Tuning Setting | Time |
|--|---|
| Tune all motor constants (Pr. 96 = 1) | Approximately 25 to 75s (Tuning time differs according to the inverter capacity and motor type.) |
| Tune motor constants (R1) only (Pr. 96 = 11) | Approximately 9s |

Tab. 6-14: Offline auto tuning time (when the initial value is set)

NOTE

The set frequency monitor displayed during the offline auto tuning is 0Hz.

Return to normal operation

When offline auto tuning ends, press the STOP/RESET key of the operation panel during PU operation. For external operation, turn off the start signal (STF signal or STR signal) once. This operation resets the offline auto tuning and the PU's monitor display returns to the normal indication. (Without this operation, next operation cannot be started.)

NOTE

Do not change the Pr. 96 setting after completion of tuning (3 or 13). If the Pr. 96 setting is changed, tuning data is made invalid. If the Pr. 96 setting is changed, tuning must be performed again.

If offline auto tuning ended in error (see the table below), motor constants are not set. Perform an inverter reset and restart tuning.

| Pr. 96 Setting | Error Cause | Remedy |
|----------------|--|--|
| 8 | Forced end | Set "1" or "11" in Pr. 96 and perform tuning again. |
| 9 | Inverter protective function operation | Make setting again. |
| 91 | Current limit (stall prevention) function was activated. | Set "1" in Pr. 156. |
| 92 | Converter output voltage reached 75% of rated value. | Check for fluctuation of power supply voltage. |
| 93 | – Calculation error – A motor is not connected. | Check the motor wiring and make setting again. Set the rated current of the motor in Pr. 9. |

Tab. 6-15: Parameter 96 setting

When tuning is ended forcibly by pressing the STOP/RESET key or turning off the start signal (STF or STR) during tuning, offline autotuning does not end normally. (The motor constants have not been set.) Perform an inverter reset and restart tuning.

When using the motor corresponding to the following specifications and conditions, reset Pr. 9 Electronic thermal O/L relay as below after tuning is completed.

- When the rated power specifications of the motor is 200/220V(400/440V) 60Hz, set 1.1 times rated motor current value in Pr. 9.
- When performing motor protection from overheat using a PTC thermistor or motor with temperature detector such as Klixon, set "0" (motor overheat protection by the inverter is invalid) in Pr. 9.

NOTES

The motor constants measured once in the offline auto tuning are stored as parameters and their data are held until the offline auto tuning is performed again.

An instantaneous power failure occurring during tuning will result in a tuning error. After power is restored, the inverter goes into the normal operation mode. Therefore, when STF (STR) signal is on, the motor runs in the forward (reverse) rotation.

Any alarm occurring during tuning is handled as in the ordinary mode. Note that if a fault retry has been set, retry is ignored.



CAUTION:

As the motor may run slightly, fix the motor securely with a mechanical brake or make sure that there will be no problem in safety if the motor runs (caution is required especially in elevator). Note that tuning performance is unaffected even if the motor runs slightly.

Utilizing or changing offline auto tuning data for use

The data measured in the offline auto tuning can be read and utilized or changed.

① Set Pr. 71 according to the motor used.:

| Motor | | Pr. 71 ① |
|--|--------------------------|----------|
| Mitsubishi standard motor, Mitsubishi high efficiency motor | SF-JR | 4 |
| | SF-JR 4P (1.5kW or less) | 24 |
| | SF-HR | 44 |
| | Others | 4 |
| Mitsubishi constant-torque motor | SF-JRCA 4P | 14 |
| | SF-HRCA 4P | 54 |
| | Others (SF-JRC, etc.) | 14 |
| Other manufacturer's standard motor | — | 4 |
| Other manufacturer's constant-torque motor | — | 14 |

Tab. 6-16: Motor selection

① For other settings of Pr. 71, refer to section 6.8.2.

② In the parameter setting mode, read the following parameters and set desired values.

| Parameter | Name | Setting Range | Setting Increments | Initial Value |
|-----------|--------------------------|---------------|--------------------|---------------|
| 82 | Motor excitation current | 0-****, 9999 | 1 | 9999 |
| 90 | Motor constant R1 | 0-****, 9999 | 1 | 9999 |
| 91 | Motor constant R2 | 0-****, 9999 | 1 | 9999 |
| 92 | Motor constant L1 | 0-****, 9999 | 1 | 9999 |
| 93 | Motor constant L2 | 0-****, 9999 | 1 | 9999 |
| 94 | Motor constant X | 0-****, 9999 | 1 | 9999 |
| 859 | Torque current | 0-****, 9999 | 1 | 9999 |

Tab. 6-17: Parameter setting ranges

NOTES

When "9999" is set in Pr. 82, Pr. 90 to Pr. 94, Pr. 859, Mitsubishi motor (SF-JR, SF-HR, SF-JRCA, SF-HRCA) constants are used.

As the motor constants measured in the offline auto tuning have been converted into internal data (****), refer to the following setting example when making setting:

Setting example:

To slightly increase Pr. 90 value (5%)

When Pr. 90 is displayed as "2516", set 2642, i.e. $2516 \times 1.05 = 2641.8$, in Pr. 90.

(The value displayed has been converted into a value for internal use. Hence, simple addition of a given value to the displayed value has no significance.)

Method to set the motor constants without using the offline auto tuning data

The Pr. 90 to Pr. 94 motor constants may either be entered in [Ω , m Ω] or in [mH]. Before starting operation, confirm which motor constant unit is used.

To enter the Pr. 90 to Pr. 94 motor constants in [Ω]/[m Ω]

① Set Pr. 71 according to the motor used:

| | Star Connection Motor | Delta Connection Motor |
|-----------------------|-----------------------|------------------------|
| Standard motor | 5 | 6 |
| Constant-torque motor | 15 | 16 |

Tab. 6-18: Setting of parameter 71

② In the parameter setting mode, read the following parameters and set desired values.

I_q = torque current, I_{100} = rated current, I_0 = no load current

$$I_q = \sqrt{I_{100}^2 - I_0^2}$$

| Pr. | Name | Setting Range | Setting Increments | Initial Value |
|-----|--|-----------------------|--------------------|---------------|
| 82 | Motor excitation current (no load current) | 0–500A, 9999 | 0.01A | 9999 |
| 90 | Motor constant R1 | 0–50 Ω , 9999 | 0.001 Ω | 9999 |
| 91 | Motor constant R2 | 0–50 Ω , 9999 | 0.001 Ω | 9999 |
| 92 | Motor constant L1 | 0–50 Ω , 9999 | 0.001 Ω | 9999 |
| 93 | Motor constant L2 | 0–50 Ω , 9999 | 0.001 Ω | 9999 |
| 94 | Motor constant X | 0–500 Ω , 9999 | 0.01 Ω | 9999 |
| 859 | Torque current | 0–500A, 9999 | 0.01A | 9999 |

Tab. 6-19: Setting of parameter 82, 90 to 94 and 859

③ Refer to the following table and set Pr. 83 and Pr. 84.

| Pr. | Name | Setting Range | Setting Increments | Initial Value |
|-----|-----------------------|---------------|--------------------|---------------|
| 83 | Motor rated voltage | 0–1000V | 0.1V | 400V |
| 84 | Rated motor frequency | 10–120Hz | 0.01Hz | 50Hz |

Tab. 6-20: Setting of parameter 83 and 84

NOTES

When "9999" is set in Pr. 82, Pr. 90 to Pr. 94, Pr. 859, Mitsubishi motor (SF-JR, SF-HR, SF-JRCA, SF-HRCA) constants are used.

If "star connection" is mistaken for "delta connection" or vice versa during setting of Pr. 71, advanced magnetic flux vector control and general-purpose magnetic flux vector control cannot be exercised properly.

To enter the Pr. 90 and Pr. 94 motor constants in [mH]

① Set Pr. 71 according to the motor used:

| Motor | | Pr. 71 ① |
|--|------------|----------|
| Mitsubishi standard motor, Mitsubishi high efficiency motor | SF-JR | 0 |
| | SF-HR | 40 |
| Mitsubishi constant-torque motor | SF-JRCA 4P | 1 |
| | SF-HRCA | 50 |

Tab. 6-21: Motor selection

① For other settings of Pr. 71, refer to section 6.8.2.

② In the parameter setting mode, read the following parameters and set desired values.
Calculate the Pr. 94 value from the following formula.

$$\text{Pr. 94} = \left(1 - \frac{M^2}{L1 \times L2} \right) \times 100 [\%]$$

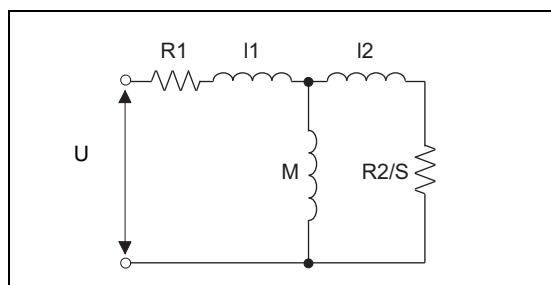

Fig. 6-40:
Motor equivalent circuit diagram

1001556E

- R1: Primary resistance
- R2: Secondary resistance
- l1: Primary leakage inductance
- l2: Secondary leakage inductance
- M: Excitation inductance
- S: Slip
- L1 = l1 + M: Primary inductance
- L2 = l2 + M: Secondary inductance

| Pr. | Name | Setting Range | Setting Increments | Initial Value |
|-----|---|----------------|--------------------|---------------|
| 82 | Motor excitation current (no load current) | 0–500A, 9999 | 0.01A | 9999 |
| 90 | Motor constant R1 | 0–50Ω, 9999 | 0.001Ω | 9999 |
| 91 | Motor constant R2 | 0–50Ω, 9999 | 0.001Ω | 9999 |
| 92 | Motor constant L1 | 0–1000mH, 9999 | 0.1mH | 9999 |
| 93 | Motor constant L2 | 0–1000mH, 9999 | 0.1mH | 9999 |
| 94 | Motor constant X | 0–100%, 9999 | 0.1% | 9999 |
| 859 | Torque current | 0–500A, 9999 | 0.01A | 9999 |

Tab. 6-22: Setting of parameter 82, 90 to 94 and 859

③ Refer to the following table and set Pr. 83 and Pr. 84.

| Pr. | Name | Setting Range | Setting Increments | Initial Value |
|-----|-----------------------|---------------|--------------------|---------------|
| 83 | Motor rated voltage | 0–1000V | 0.1V | 400V |
| 84 | Rated Motor Frequency | 10–120Hz | 0.01Hz | 50Hz |

Tab. 6-23: Setting of parameter 83 and 84

NOTE

When "9999" is set in Pr. 82, Pr. 90 to Pr. 94, Pr. 859, Mitsubishi motor (SF-JR, SF-HR, SF-JRCA, SF-HRCA) constants are used.

6.9 Motor brake and stop operation

| Purpose | Parameters that must be set | | Refer to Section |
|---|------------------------------------|--|------------------|
| Motor braking torque adjustment | DC injection brake | Pr. 10–Pr. 12 | 6.9.1 |
| Improve the motor braking torque with an option | Selection of a regenerative brake | Pr. 30, Pr. 70 | 6.9.2 |
| Coast the motor to a stop | Selection of motor stopping method | Pr. 250 | 6.9.3 |
| Used to stop the motor with a mechanical brake (vibration restraint at stop-on-contact) | Stop-on-contact control | Pr. 6, Pr. 48, Pr. 270, Pr. 275, Pr. 276 | 6.9.4 |
| Used to stop the motor with a mechanical brake (operation timing of a mechanical brake) | Brake sequence function | Pr. 278–Pr. 283, Pr. 292 | 6.9.5 |

6.9.1 DC injection brake (Pr. 10 to Pr. 12)

The FR-E700 EC frequency inverter has an adjustable DC brake function.

This function uses the eddy current brake principle, stopping the motor by applying a pulsed DC voltage to the motor stator.

The pulsed DC voltage applied to the motor stator can achieve stopping torques of around 25 to 30% of the motor’s rated torque.

| Pr. No. | Name | Initial Value | | Setting Range | Description | Parameters referred to | Refer to Section |
|---------|--|---|----|---------------|---|------------------------|------------------|
| 10 | DC injection brake operation frequency | 3Hz | | 0–120Hz | Set the operation frequency of the DC injection brake. | 13 Starting frequency | 6.7.2 |
| | | | | | | | |
| 11 | DC injection brake operation time | 0.5s | | 0 | DC injection brake disabled | 71 Applied motor | 6.8.2 |
| | | | | 0.1–10s | Set the operation time of the DC injection brake. | | |
| 12 | DC injection brake operation voltage | FR-E720S-008 to 015 | 6% | 0–30% | Set the DC injection brake voltage (torque). When "0" is set, DC injection brake is disabled. | | |
| | | FR-E720S-030 to 110, FR-E740-016 to 170 | 4% | | | | |
| | | FR-E740-230 and 300 | 2% | | | | |

The above parameters can be set when Pr. 160 "User group read selection" = 0.

Operation frequency setting (Pr. 10)

When the frequency at which the DC injection brake operates is set to Pr. 10, the DC injection brake is operated when this frequency is reached during deceleration.

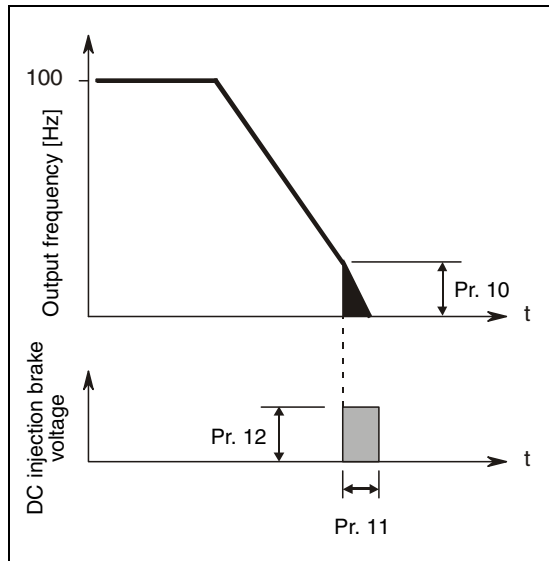
**Fig. 6-41:**

When Pr. 11 is set to a value between 0.1 and 10s

1000007C

Operation time setting (Pr. 11)

Use Pr. 11 to set the duration period the DC injection brake is applied.

When the motor does not stop due to large load moment (J), increasing the setting produces an effect.

When Pr. 11 = 0s, the DC injection brake is not operated. (At a stop, the motor coasts.)

Operation voltage (torque) setting (Pr. 12)

Use Pr. 12 to set the percentage to the power supply voltage.

When Pr. 12 = 0%, the DC injection brake is not operated. (At a stop, the motor coasts.)

When using the constant-torque motor (SF-JRCA) and energy saving motor (SF-HR, SF-HRCA), change the Pr.12 setting as follows:

Constant-torque motor:

FR-E720S-110 or less, FR-E740-095 or less4%

FR-E740-120 or more2%

Energy saving motor SF-HR, SF-HRCA:

FR-E720S-110 or less, FR-E740-095 or less.....4%

FR-E740-120 and 1703%

FR-E740-230 and 3002%

NOTES

For the FR-E740-120 and 170, when the Pr. 12 setting is the following, changing the Pr. 71 "Applied motor" setting automatically changes the Pr. 12 setting. Therefore, it is not necessary to change the Pr. 12 setting.

Parameter 12 = 4% (initial value)

The Pr. 12 setting is automatically changed to 2% if the Pr. 71 value is changed from the value selecting the standard motor (0, 3 to 6, 23, 24, 40, 43, 44) to the value selecting the constant torque motor (1, 13 to 16, 50, 53, 54).

Parameter 12 = 2%

The Pr. 12 setting is automatically changed to 4% (initial value) if the Pr. 71 value is changed from the value selecting the constant torque motor (1, 13 to 16, 50, 53, 54) to the value selecting the standard motor (0, 3 to 6, 23, 24, 40, 43, 44).

Even if the Pr. 12 setting is increased, braking torque is limited so that the output current is within the rated inverter current.

As stop holding torque is not produced, install a mechanical brake.

6.9.2 Selection of a regenerative brake (Pr. 30, Pr. 70)

- When making frequent starts/stops, use the optional high-duty brake resistor (FR-ABR, MRS) and brake unit (FR-BU2) to increase the regenerative brake duty.
- Use a power regeneration common converter (FR-CV) for continuous operation in regeneration status.
Use the high power factor converter (FR-HC) to reduce harmonics, improve the power factor, or continuously use the regenerative status.

| Pr. No. | Name | Initial Value | Setting Range | Description | Parameters referred to | Refer to Section |
|-----------|---------------------------------|---------------|---------------|---|--|------------------|
| 30 | Regenerative function selection | 0 | 0 | Brake resistor MRS, Brake unit (FR-BU2) Power regeneration common converter (FR-CV) High power factor converter (FR-HC) | 57 Restart coasting time | 6.12.1 |
| | | | 1 | High-duty brake resistor (FR-ABR) | 178-184 Input terminal function selection | 6.10.1 |
| | | | 2 | High power factor converter (FR-HC) when automatic restart after instantaneous power failure is selected | 190-192 Output terminal function selection | 6.10.5 |
| 70 | Special regenerative brake duty | 0% | 0-30% | Brake duty when using the high-duty brake resistor (FR-ABR) | | |

The above parameters can be set when Pr. 160 "User group read selection" = 0.

When using the brake resistor (MRS), the brake unit (FR-BU2), power regeneration common converter (FR-CV), and high power factor converter (FR-HC).

Set Pr. 30 to "0" (initial value). The Pr. 70 setting is made invalid. At this time, the regenerative brake duty is as follows.

- FR-E720S-030 or more3%
- FR-E740-016 or more.....2%
- Assign the inverter operation enable signal (X10) to the contact input terminal.
To make protective coordination with the FR-HC and FR-CV, use the inverter operation enable signal to shut off the inverter output.
Input the RDY signal of the FR-HC (RDYB signal of the FR-CV).
- For the terminal used for X10 signal input, assign its function by setting "10" (X10) to any of Pr. 178 to Pr. 184.

When using the high-duty brake resistor (FR-ABR) (FR-E720S-030 or more, FR-E740-016 or more)

Set "1" in Pr. 30. Set Pr. 70 as follows.

- FR-E720S-100 or less, FR-E740-170 or less..... 10%
- FR-E740-230 and 300 6%

When a high power factor converter (FR-HC) is used and automatic restart after instantaneous power failure function is made valid.

- When automatic restart after instantaneous power failure function of both the FR-HC and inverter is made valid (when a value other than "9999" is set in Pr. 57 "Restart coasting time"), set "2" in Pr. 30.
- Set Pr. 70 to "0%" (initial value).
- When the FR-HC detects power failure during inverter operation, the RDY signal turns on, resulting in the motor coasting. Turning the RDY signal off after power restoration, the inverter detects the motor speed (depends on the Pr. 162 "Automatic restart after instantaneous power failure selection") and restarts automatically after instantaneous power failure.

Regenerative brake duty alarm output and alarm signal (RBP signal)

- [RB] appears on the operation panel and an alarm signal (RBP) is output when 85% of the regenerative brake duty set in Pr. 70 is reached. If the regenerative brake duty reaches 100% of the Pr. 70 setting, a regenerative overvoltage (E.OV1 to E.OV3) occurs. Note that [RB] is not displayed when Pr. 30 = "0".
- The inverter does not trip even when the alarm (RBP) signal is output.
- For the terminal used for the RBP signal output, assign the function by setting "7 (positive logic) or 107 (negative logic)" in any of Pr. 190 to Pr. 192 "Output terminal function selection".

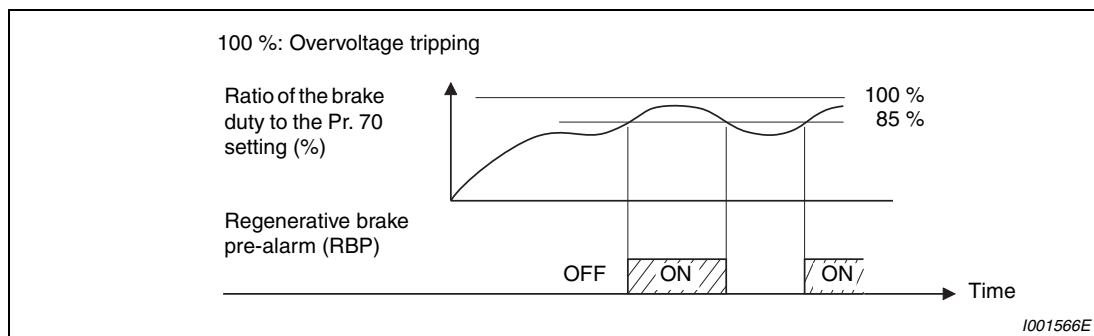

Fig. 6-42: Regenerative overload

NOTES

- | The MRS signal can also be used instead of the X10 signal.
- | Refer to section 3.7 for connecting the high-duty brake resistor (MRS, FR-ABR), brake unit (FR-BU2), high power factor converter (FR-HC), and power regeneration common converter (FR-CV).
- | When terminal assignment is changed using Pr. 178 to Pr. 184 "Input terminal function selection" and Pr. 190 to Pr. 192 "Output terminal function selection", the other functions may be affected. Make setting after confirming the function of each terminal.



CAUTION:

The value set in Pr. 70 must not exceed the setting of the brake resistor used. Otherwise, the resistor can overheat.

6.9.3 Stop selection (Pr. 250)

Used to select the stopping method (deceleration to a stop or coasting) when the start signal turns off. Used to stop the motor with a mechanical brake, etc. together with switching off of the start signal. You can also select the operations of the start signals (STF/STR). (Refer to section 6.10.4 for start signal selection.)

| Pr. No. | Name | Initial Value | Setting Range | Description | | Parameters referred to | Refer to Section |
|---------|----------------|---------------|---------------|--|---|---|-------------------------|
| | | | | Start Signal (STF/STR) | Stop Operation | | |
| 250 | Stop selection | 9999 | 0-100s | STF: Forward rotation start STR: Reverse rotation start | The motor is coasted to a stop when the preset time elapses after the start signal is turned off. | 7 Acceleration time 8 Deceleration time 13 Starting frequency | 6.7.1 6.7.1 6.7.2 |
| | | | 1000s - 1100s | STF: Start signal STR: Forward/reverse signal | The motor is coasted to a stop (Pr. 250 - 1000)s after the start signal is turned off. | | |
| | | | 9999 | STF: Forward rotation start STR: Reverse rotation start | When the start signal is turned off, the motor decelerates to stop. | | |
| | | | 8888 | STF: Start signal STR: Forward/reverse signal | | | |

The above parameter can be set when Pr. 160 "User group read selection" = 0.

Set Pr. 250 to "9999" (initial value) or "8888". The motor decelerates to a stop when the start signal (STF/STR) turns off.

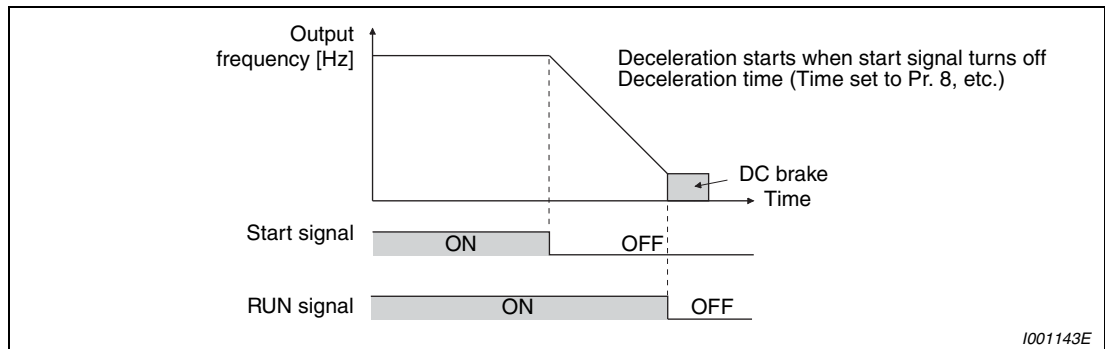

Fig. 6-43: Stop operation when parameter 250 = 9999

Use Pr. 250 to set the time from when the start signal turns off until the output is shut off. When any of "1000" to "1100" is set, the output is shut off after (Pr. 250 – 1000)s. The output is shut off when the time set in Pr. 250 has elapsed after the start signal had turned off. The motor coasts to a stop.

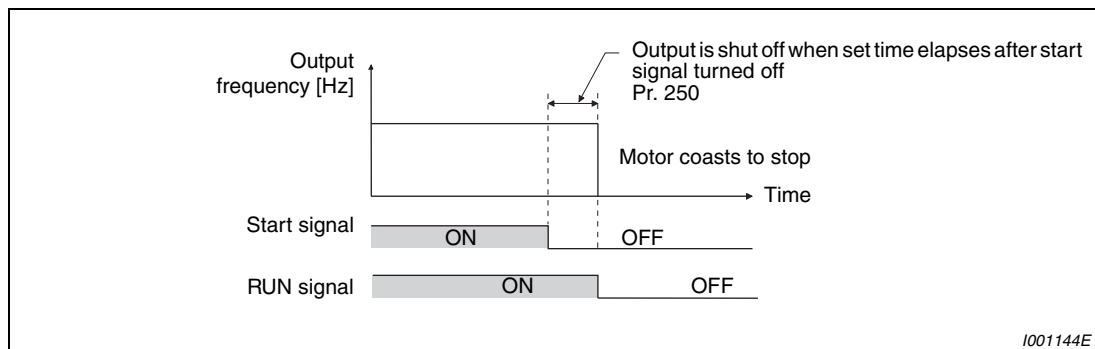

Fig. 6-44: Stop operation when parameter 250 \neq 8888 or 9999

NOTES

The RUN signal turns off when the output stops.

Stop selection is invalid when the following functions are activated.

- Power failure stop function (Pr. 261)
- PU stop (Pr. 75)
- Deceleration stop because of communication error (Pr. 502)
- Emergency stop by LonWorks communication

When setting of Pr. 250 is not 9999 nor 8888, acceleration/deceleration is performed according to the frequency command, until start signal is OFF and output is shutoff.

When the start signal is turned on again during motor coasting, the motor starts at Pr. 13 "Starting frequency".

6.9.4 Stop-on contact control function

(Pr. 6, Pr. 48, Pr. 270, Pr. 275, Pr. 276) **AD MFVC** **GP MFVC**

To ensure accurate positioning at the upper limit etc. of a lift, stop-on-contact control causes a mechanical brake to be closed while the motor is developing a holding torque to keep the load in contact with a mechanical stopper etc. This function suppresses vibration which is liable to occur when the load is stopped upon contact in vertical motion applications, ensuring steady precise positioning.

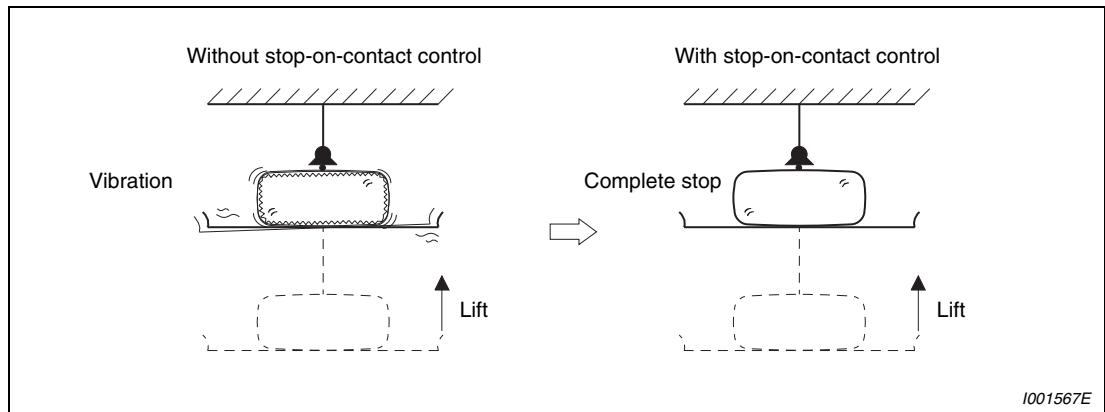

Fig. 6-45: Suppressing vibration in vertical motion applications

| Pr. No. | Name | Initial Value | Setting Range | Description | Parameters referred to | Refer to Section |
|------------|---|---------------|---------------|--|--|------------------|
| 6 | Multi-speed setting (low speed) | 10Hz | 0–400Hz | Sets the output frequency for stop-on-contact control. | 4–6 Multi-speed setting | 6.6.1 |
| 48 | Second stall prevention operation current ① | 9999 | 0–200% | Sets the stall prevention operation level for stall prevention operation level. | 24–27 Jog frequency | 6.6.2 |
| | | | 9999 | Pr. 22 setting | 48 Second stall prevention operation current | 6.3.5 |
| 270 | Stop-on contact control selection ① | 0 | 0 | Normal operation | 59 Remote function selection | 6.6.3 |
| | | | 1 | Stop-on-contact control | 72 PWM frequency selection | 6.15.1 |
| 275 | Stop-on contact excitation current low-speed multiplying factor ① | 9999 | 0–300% | Set the force (holding torque) for stop-on-contact control. Normally set 130% to 180%. | 79 Operation mode selection | 6.18.1 |
| | | | 9999 | Without compensation | 128 PID action selection | 6.20.1 |
| 276 | PWM carrier frequency at stop-on contact ① | 9999 | 0–9 | Sets a PWM carrier frequency for stop-on-contact control. | 178–184 Input terminal function selection | 6.10.1 |
| | | | 9999 | As set in Pr. 72 "PWM frequency selection". | 292 Automatic acceleration/deceleration | 6.7.4 |

① The parameter can be set when Pr. 160 "User group read selection" = 0.

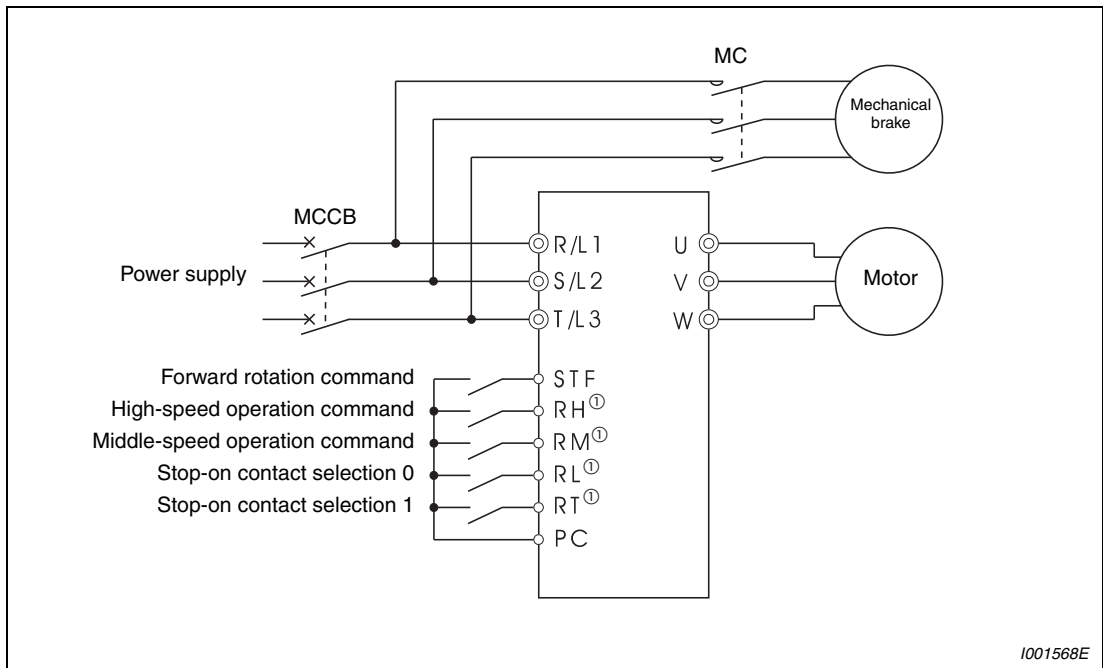

Fig. 6-46: Connection example

① The input signal terminal used differs according to the Pr. 180 to Pr. 184 settings.

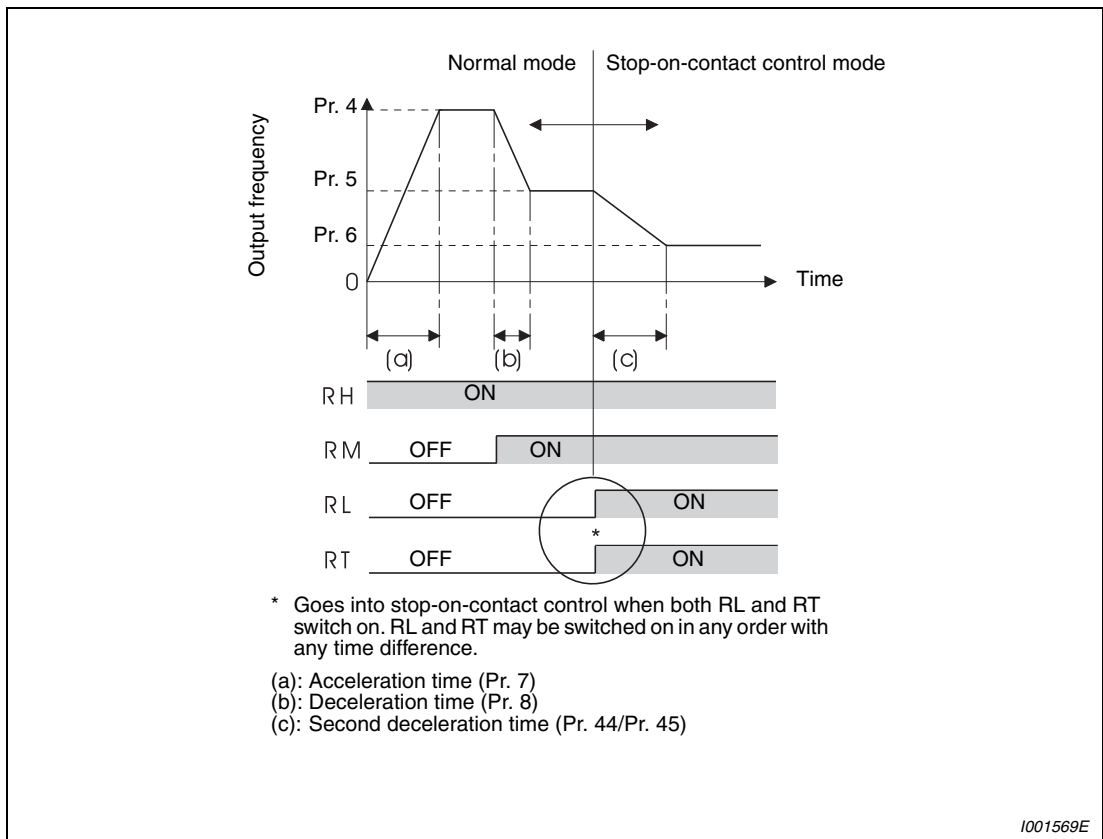

Fig. 6-47: Switching to the stop-on contact control mode

Set stop-on-contact control

- Make sure that the inverter is in external operation mode. (Refer to section 6.18.1.)
- Select advanced magnetic flux vector control or general-purpose magnetic flux vector control.
- Set "1" in Pr. 270 "Stop-on contact control selection".
- Set output frequency during stop-on-contact control in Pr. 6 "Multi-speed setting (low speed)".
The frequency should be as low as possible (about 2Hz). If it is set to more than 30Hz, the operating frequency will be 30Hz.
- When both the RT and RL signals are switched on, the inverter enters the stop-on-contact mode, in which operation is performed at the frequency set in Pr. 6 independently of the preceding speed.
- For the terminal used for X18 signal input, set "3" in any of Pr. 178 to Pr. 184 "Input terminal function selection" and "0" in Pr. 178 to Pr. 184 "Input terminal function selection" to assign the function.

NOTES

- By increasing the Pr. 275 setting, the low-speed (stop-on-contact) torque increases, but overcurrent fault (E.OCT) may occur or the machine may oscillate in a stop-on-contact state.
- The stop-on-contact function is different from servo-lock function, and if used to stop or hold a load for an extended period, this function can cause the motor to overheat. After a stop, immediately change to a mechanical brake to hold the load.
- Under the following operating conditions, the stop-on-contact function is made invalid:
 - PU operation (Pr. 79)
 - Jog operation (JOG signal)
 - PU+external operation (Pr. 79)
 - PID control function operation (Pr.128)
 - remote setting function operation (Pr. 59)
 - automatic acceleration/deceleration operation (Pr. 292)

Function switching of stop-on-contact control selection

| Main Functions | Normal Operation (either RL or RT is off or both are off) | With stop-on-contact Control (both RL and RT are on) |
|---|---|--|
| Output frequency | Multi-speed 0 to 5V/0 to 10V/4 to 20mA etc. | Pr. 6 |
| Stall prevention operation level | Pr. 22 | Pr. 48 (Pr. 22 when Pr. 48 = 9999) |
| Excitation current low speed scaling factor | — | Only Pr. 275 (0 to 300%) is compensated before both RL and RT turn on. |
| Carrier frequency | Pr. 72 | Output frequency is 3Hz or less When Pr. 276 setting (Pr. 72 when Pr. 276 = 9999) |
| Fast-response current limit | Valid | Invalid |

Tab. 6-24: Function switching of stop-on-contact control selection

Set frequency when stop-on-contact control (Pr. 270 = 1) is selected

The following table lists the frequencies set when the input terminals (RH, RM, RL, RT, JOG) are selected together.



Stop-on-contact control is invalid when remote setting function is selected (Pr. 59 = 1 to 3).

| Input Signal | | | | | Stop-on Contact | Set Frequency |
|--------------|----|----|----|-----|-----------------|--|
| RH | RM | RL | RT | JOG | | |
| ON | | | | | | Pr. 4 "Multi-speed setting (high speed)" |
| | ON | | | | | Pr. 5 "Multi-speed setting (middle speed)" |
| | | ON | | | | Pr. 6 "Multi-speed setting (low speed)" |
| | | | ON | | | By 0 to 5V (0 to 10V), 4 to 20mA input |
| | | | | ON | | Pr. 15 "Jog frequency" |
| ON | ON | | | | | Pr. 26 "Multi-speed setting (speed 6)" |
| ON | | ON | | | | Pr. 25 "Multi-speed setting (speed 5)" |
| ON | | | ON | | | Pr. 4 "Multi-speed setting (high speed)" |
| ON | | | | ON | | Pr. 15 "Jog frequency" |
| | ON | ON | | | | Pr. 24 "Multi-speed setting (speed 4)" |
| | ON | | ON | | | Pr. 5 "Multi-speed setting (middle speed)" |
| | ON | | | ON | | Pr. 15 "Jog frequency" |
| | | ON | ON | | Valid | Pr. 6 "Multi-speed setting (low speed)" |
| | | ON | | ON | | Pr. 15 "Jog frequency" |
| | | | ON | ON | | Pr. 15 "Jog frequency" |
| | | ON | ON | ON | | Pr. 15 "Jog frequency" |
| | ON | | ON | ON | | Pr. 15 "Jog frequency" |
| | ON | ON | | ON | | Pr. 15 "Jog frequency" |
| | ON | ON | ON | | Valid | Pr. 6 "Multi-speed setting (low speed)" |
| ON | | | ON | ON | | Pr. 15 "Jog frequency" |
| ON | | ON | | ON | | Pr. 15 "Jog frequency" |
| ON | | ON | ON | | Valid | Pr. 6 "Multi-speed setting (low speed)" |
| ON | ON | | | ON | | Pr. 15 "Jog frequency" |
| ON | ON | | ON | | | Pr. 26 "Multi-speed setting (speed 6)" |
| ON | ON | ON | | | | Pr. 27 "Multi-speed setting (speed 7)" |
| | ON | ON | ON | ON | | Pr. 15 "Jog frequency" |
| ON | | ON | ON | ON | | Pr. 15 "Jog frequency" |
| ON | ON | | ON | ON | | Pr. 15 "Jog frequency" |
| ON | ON | ON | | ON | | Pr. 15 "Jog frequency" |
| ON | ON | ON | ON | | Valid | Pr. 6 "Multi-speed setting (low speed)" |
| ON | ON | ON | ON | ON | | Pr. 15 "Jog frequency" |
| | | | | | | By 0 to 5V (0 to 10V), 4 to 20mA input |

Tab. 6-25: Frequency and combined input signals

NOTE

Changing the terminal function using any of Pr. 178 to Pr. 184 may affect the other functions. Make setting after confirming the function of each terminal.

6.9.5 Brake sequence function (Pr. 278 to Pr. 283, Pr. 292)  

This function is used to output from the inverter the mechanical brake operation timing signal in vertical lift and other applications. This function prevents the load from dropping with gravity at a start due to the operation timing error of the mechanical brake or an overcurrent alarm from occurring at a stop, ensuring secure operation.

| Pr. No. | Name | Initial Value | Setting Range | Description | Parameters referred to | Refer to Section |
|------------|--------------------------------------|---------------|---------------|---|--|------------------|
| 278 | Brake opening frequency | 3Hz | 0-30Hz | Set to the rated slip frequency of the motor + about 1.0Hz. This parameter may be set only if Pr. 278 ≤ Pr. 282. | 80 Motor capacity | 6.2.1 |
| 279 | Brake opening current | 130% | 0-200% | Generally, set this parameter to about 50 to 90%. If the setting is too low, the load is liable to drop due to gravity at start. Suppose that the rated inverter current is 100%. | 81 Number of motor poles | 6.2.1 |
| 280 | Brake opening current detection time | 0.3s | 0-2s | Generally, set this parameter to about 0.1 to 0.3s. | 180-184 Input terminal function selection | 6.10.1 |
| 281 | Brake operation time at start | 0.3s | 0-5s | When Pr. 292 = 7, set the mechanical delay time until the brake is loosened. Set the mechanical delay time until the brake is loosened + about 0.1 to 0.2s when Pr. 292 = 8. | 190-192 Output terminal function selection | 6.10.5 |
| 282 | Brake operation frequency | 6Hz | 0-30Hz | Set the frequency to activate the mechanical brake by turning off the brake opening request signal (BOF). Generally, set this parameter to the Pr. 278 setting + 3 to 4Hz. This parameter may be set only if Pr. 278 ≤ Pr. 282. | 800 Control method selection | 6.3.2 |
| 283 | Brake operation time at stop | 0.3s | 0-5s | Set the mechanical delay time until the brake is closed + 0.1s when Pr. 292 = 7. Sets the mechanical delay time until the brake is closed + 0.2 to 0.3s when Pr. 292 = 8. | | |
| 292 | Automatic acceleration/ deceleration | 0 | 0 | Normal operation mode | | |
| | | | 1/11 | Shortest acceleration/deceleration mode (Refer to page 6-78.) | | |
| | | | 7 | Brake sequence mode 1 | | |
| | | | 8 | Brake sequence mode 2 | | |

The above parameters can be set when Pr. 160 "User group read selection" = 0.

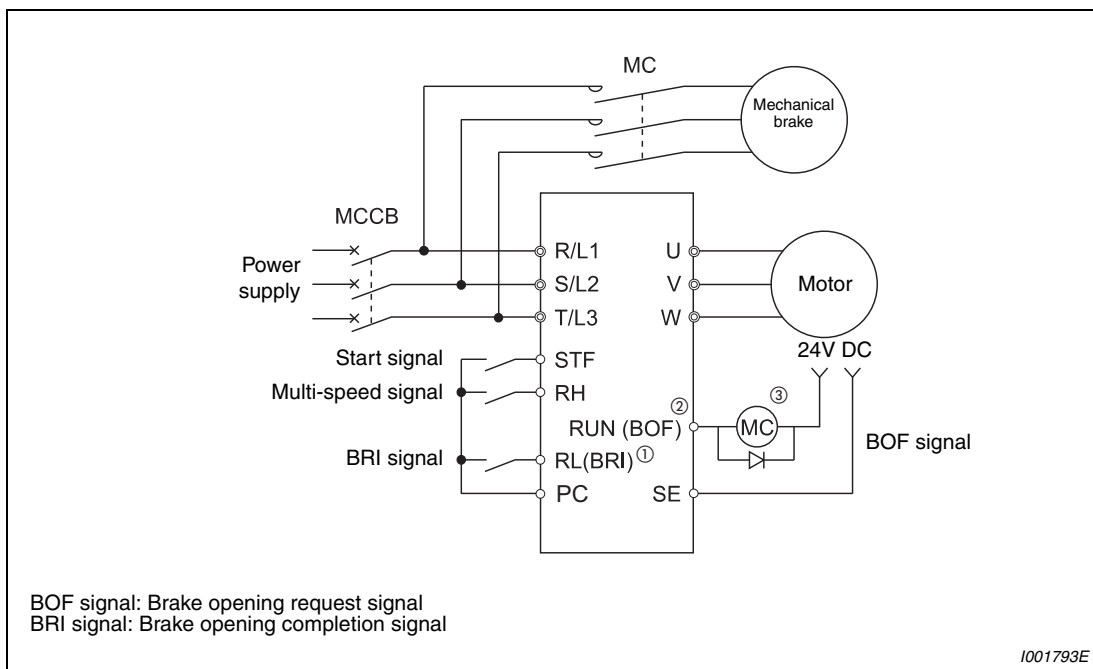

Fig. 6-48: Connection example with mechanical brake (Pr. 184 = 15, Pr. 190 = 20)

- ① The input signal terminal used differs according to the Pr. 178 to Pr. 184 settings.
- ② The output signal terminal used differs according to the Pr. 190 to Pr. 192 settings.
- ③ The current should be within the permissible current of transistor in the inverter. (24V/0.1A DC)

NOTES

- When brake sequence mode is selected, automatic restart after instantaneous power failure is invalid.
- When using this function, set the acceleration time to 1s or longer.
- Changing the terminal function using any of Pr. 178 to Pr. 184 and Pr. 190 to Pr. 192 may affect the other functions. Make setting after confirming the function of each terminal.

Set the brake sequence mode

- Select advanced magnetic flux vector control or general-purpose magnetic flux vector control. The brake sequence function is valid only when the external operation mode, external/PU combined operation mode 1 or network operation mode is selected.
- Set "7 or 8" (brake sequence mode) in Pr. 292. To ensure more complete sequence control, it is recommended to set "7" (brake opening completion signal input) in Pr. 292.
- Set "15" in any of Pr. 178 to Pr. 184 "Input terminal function selection" and assign the brake opening completion signal (BRI) to the input terminal.
- Set "20 (positive logic)" or "120 (negative logic)" in any of Pr. 190 to Pr. 192 "Output terminal function selection" and assign the brake opening request signal (BOF) to the output terminal.



CAUTION:

In lift applications where an inadvertent lifting of the holding brake can lead to personal injury or property damage, the BOF signal may be used for safety reasons only in positive logic, that is, setting "20".

With brake opening completion signal input (Pr. 292 = 7)

- When the start signal is input to the inverter, the inverter starts running. When the internal speed command reaches the value set in Pr. 278 and the output current is not less than the value set in Pr. 279, the inverter outputs the brake opening request signal (BOF) after the time set in Pr. 280 has elapsed.
- When the time set in Pr. 281 elapses after the brake opening completion signal (BRI) was activated, the inverter increases the output frequency to the set speed.
- When the speed has decreased to the frequency set in Pr. 282 during deceleration, the BOF signal is turned off. When the time set in Pr. 283 elapses after the electromagnetic brake operation was completed and the BRI signal was turned off, the inverter output is switched off.

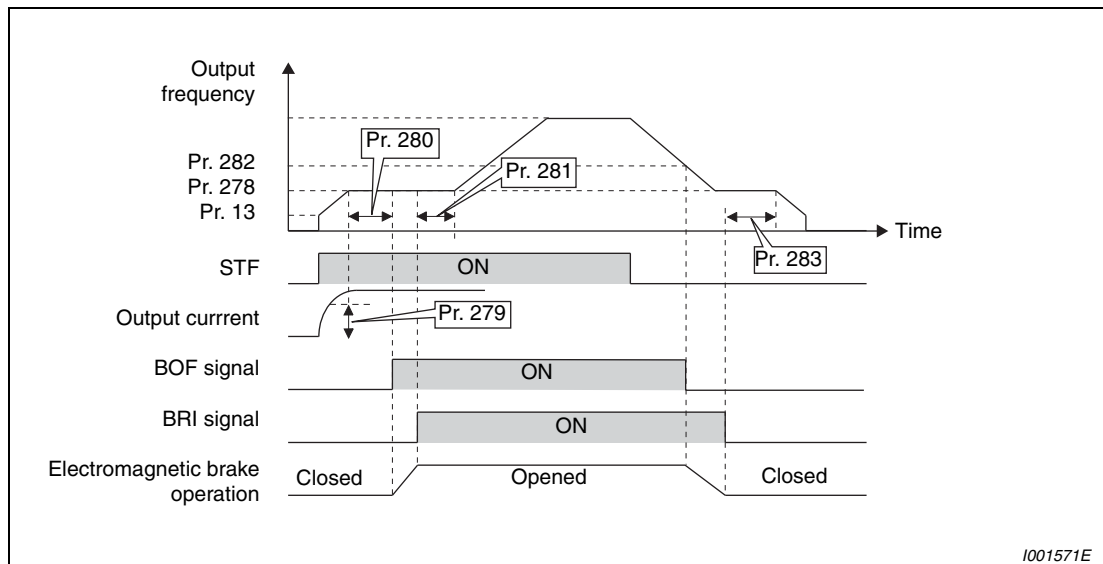

Fig. 6-49: Operation when parameter 292 = 7

With brake opening completion signal input (Pr. 292 = 8)

- When the start signal is input to the inverter, the inverter starts running. When the internal speed command reaches the value set in Pr. 278 and the output current is not less than the value set in Pr. 279, the inverter outputs the brake opening request signal (BOF) after the time set in Pr. 280 has elapsed. When the time set in Pr. 281 elapses after the BOF signal is output, the inverter increases the output frequency to the set speed.
- When the speed has decreased to the frequency set in Pr. 282 during deceleration, the brake opening request signal (BOF) is turned off. When the time set in Pr. 283 has elapsed after the BOF signal is turned off, the inverter output is switched off.

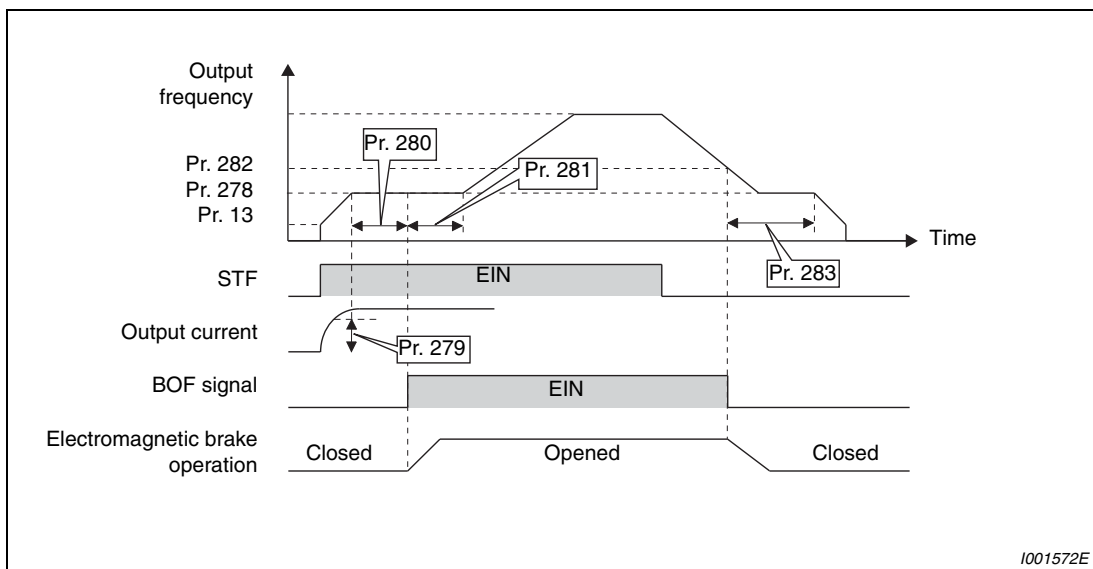

Fig. 6-50: Operation when parameter 292 = 8

NOTE

If brake sequence mode has been selected, inputting the jog signal (jog operation) or RT signal (second function selection) during an inverter stop will make brake sequence mode invalid and give priority to jog operation or second function selection. Note that JOG and RT signal input is invalid even if JOG signal and RT signal are input during operation in brake sequence mode.

Protective functions

If any of the following errors occurs in the brake sequence mode, the inverter results in a fault, trips, and turns off the brake opening request signal (BOF).

| Fault Display | Description |
|---------------|--|
| E.MB4 | Although more than 2s have elapsed after the start command (forward or reverse rotation) is input, the brake opening request signal (BOF) does not turn on. |
| E.MB5 | Although more than 2s have elapsed after the brake opening request signal (BOF) turned on, the brake opening completion signal (BRI) does not turn on. |
| E.MB6 | Though the inverter had turned on the brake opening request signal (BOF), the brake opening completion signal (BRI) turned off midway. |
| E.MB7 | Although more than 2s have elapsed after the brake opening request signal (BOF) turned off at a stop, the brake opening completion signal (BRI) does not turn off. |

Tab. 6-26: Protective functions

NOTES

A too large setting of Pr. 278 "Brake opening frequency" activates stall prevention operation and may cause E.MB4.

If the sum of the time between Pr. 13 "Starting frequency" and Pr. 278 "Brake opening frequency" + Pr. 280 "Brake opening current detection time" is more than 2s, E.MB4 occurs.

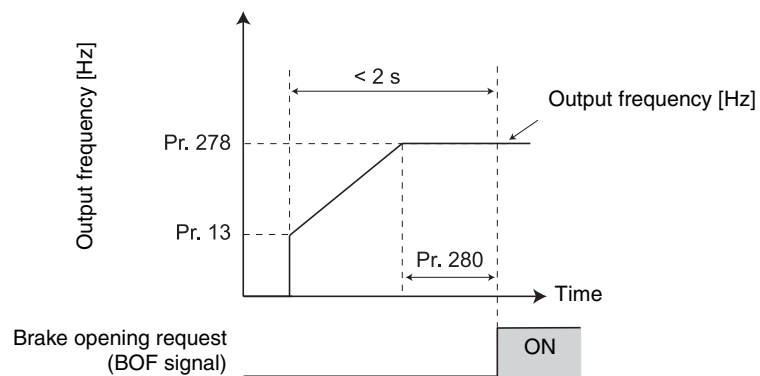

6.10 Function assignment of external terminals

| Purpose | Parameters that must be set | | Refer to Section |
|--|---|-----------------|------------------|
| Assign function to input terminal | Input terminal function selection | Pr. 178–Pr. 184 | 6.10.1 |
| Set MRS signal (output shutoff) to normally closed contact specification | MRS input selection | Pr. 17 | 6.10.2 |
| Assign start signal and forward/reverse command to other signals | Start signal (STF/STR) operation selection | Pr. 250 | 6.10.4 |
| Assign function to output terminal | Output terminal function selection | Pr. 190–Pr. 192 | 6.10.5 |
| Detect output frequency | Up-to-frequency sensitivity Output frequency detection | Pr. 41–Pr. 43 | 6.10.6 |
| Detect output current | Output current detection Zero current detection | Pr. 150–Pr. 153 | 6.10.7 |
| Remote output function | Remote output | Pr. 495–Pr. 497 | 6.10.8 |

6.10.1 Input terminal function selection (Pr. 178 to Pr. 184)

Use these parameters to select/change the input terminal functions.

| Pr. No. | Name | Initial Value | Initial Signal | Setting Range | Parameters referred to | Refer to Section |
|------------|---------------------------------|---------------|-------------------------------------|---|------------------------|------------------|
| 178 | STF terminal function selection | 60 | STF (forward rotation command) | 0–5/7/8/10/12/14–16/ 18/24/25/60/62/ 65–67/9999 | — | |
| 179 | STR terminal function selection | 61 | STR (reverse rotation command) | 0–5/7/8/10/12/14–16/ 18/24/25/61/62/ 65–67/9999 | | |
| 180 | RL terminal function selection | 0 | RL (low-speed operation command) | 0–5/7/8/10/12/14–16/ 18/24/25/62/ 65–67/9999 | | |
| 181 | RM terminal function selection | 1 | RM (middle-speed operation command) | | | |
| 182 | RH terminal function selection | 2 | RH (high speed operation command) | | | |
| 183 | MRS terminal function selection | 24 | MRS (output stop) | | | |
| 184 | RES terminal function selection | 62 | RES (inverter reset) | | | |

The above parameters can be set when Pr. 160 "User group read selection" = 0.

Input terminal function assignment

| Setting | Terminal | Function | Related Parameters | Refer to Page | |
|---------|----------|---|--------------------------------|---|------------------------|
| 0 | RL | Pr. 59 = 0 (initial value) | Low-speed operation command | Pr. 4–Pr. 6, Pr. 24–Pr. 27, Pr. 232–Pr. 239 | 6-58 |
| | | Pr. 59 = 1, 2 ^① | Remote setting (setting clear) | Pr. 59 | 6-65 |
| | | Pr. 270 = 1 ^② | Stop-on contact selection 0 | Pr. 270, Pr. 275, Pr. 276 | 6-105 |
| 1 | RM | Pr. 59 = 0 (initial value) | Middle-speed operation command | Pr. 4–Pr. 6, Pr. 24–Pr. 27, Pr. 232–Pr. 239 | 6-58 |
| | | Pr. 59 = 1, 2 ^① | Remote setting (deceleration) | Pr. 59 | 6-65 |
| 2 | RH | Pr. 59 = 0 (initial value) | High-speed operation command | Pr. 4–Pr. 6, Pr. 24–Pr. 27, Pr. 232–Pr. 239 | 6-58 |
| | | Pr. 59 = 1, 2 ^① | Remote setting (acceleration) | Pr. 59 | 6-65 |
| 3 | RT | Second function selection | | Pr. 44–Pr. 51 | 6-119 |
| | | Pr. 270 = 1 ^② | Stop-on contact selection 1 | Pr. 270, Pr. 275, Pr. 276 | 6-105 |
| 4 | AU | Terminal 4 input selection | | Pr. 267 | 6-174 |
| 5 | JOG | Jog operation selection | | Pr. 15, Pr. 16 | 6-61 |
| 7 | OH | External thermal relay input ^③ | | Pr. 9 | 6-80 |
| 8 | REX | 15 speed selection (combination with three speeds RL, RM, RH) | | Pr. 4–Pr. 6, Pr. 24–Pr. 27, Pr. 232–Pr. 239 | 6-58 |
| 10 | X10 | Inverter operation enable signal (FR-HC-, FR-CV connection) | | Pr. 30, Pr. 70 | 6-101 |
| 12 | X12 | PU operation external interlock | | Pr. 79 | 6-198 |
| 14 | X14 | PID control valid terminal | | Pr. 127–Pr. 134 | 6-270 |
| 15 | BRI | Brake opening completion signal | | Pr. 278–Pr. 285 | 6-109 |
| 16 | X16 | PU-external operation switchover (turning on X16 selects external operation) | | Pr. 79, Pr. 340 | 6-207 |
| 18 | X18 | V/f switchover (V/f control is exercised when X18 is on) | | Pr. 80, Pr. 81, Pr. 800 | 6-31, 6-36, 6-39, 6-88 |
| 24 | MRS | Output stop | | Pr. 17 | 6-117 |
| 25 | STOP | Start self-holding selection | | — | 6-120 |
| 60 | STF | Forward rotation command (assigned to STF terminal (Pr. 178) only) | | — | 6-120 |
| 61 | STR | Reverse rotation command (assigned to STR terminal (Pr. 179) only) | | — | 6-120 |
| 62 | RES | Inverter reset | | — | — |
| 65 | X65 | PU/NET operation switchover (turning on X65 selects PU operation) | | Pr. 79, Pr. 340 | 6-210 |
| 66 | X66 | External/NET operation switchover (turning on X66 selects NET operation) | | Pr. 79, Pr. 340 | 6-210 |
| 67 | X67 | Command source switchover (turning on X67 makes Pr. 338 and Pr. 339 commands valid) | | Pr. 338, Pr. 339 | 6-212 |
| 9999 | — | No function | | — | — |

Tab. 6-27: Input terminal function assignment

- ① When Pr. 59 "Remote function selection" = 1 or 2, the functions of the RL, RM and RH signals are changed as given in the table.
- ② When Pr. 270 "Stop-on contact control selection" = 1, functions of RL and RT signals are changed as in the table.
- ③ The OH signal turns on when the relay contact "opens".

NOTES

Changing the terminal assignment using Pr. 178 to Pr. 184 "Input terminal function selection" may affect the other functions. Please make setting after confirming the function of each terminal.

One function can be assigned to two or more terminals. In this case, the terminal inputs are ORed.

The priorities of the speed commands are in order of jog, multi-speed setting (RH, RM, RL, REX) and PID (X14).

When the X10 signal (FR-HC, FR-CV connection - inverter operation enable signal) is not set, the MRS signal shares this function.

When the PU operation external interlock (X12) signal is not assigned at the Pr. 79 "Operation mode selection" setting of "7", the MRS signal shares this function.

Use common terminals to assign multi-speeds (7 speeds) and remote setting. They cannot be set individually. (Common terminals are used since these functions are designed for speed setting and need not be set at the same time.)

When V/f control is selected by V/f switchover (X18 signal), second function is also selected at the same time. Control between V/f and advanced (general-purpose) magnetic flux can not be switched during operation. In case control is switched between V/f and advanced (general-purpose) magnetic flux, only second function is selected.

Turning the AU signal on makes terminal 2 (voltage input) invalid.

Response time of each signal

The response time of the X10 signal and MRS signal is within 2ms.

The response time of other signals is within 20ms.

6.10.2 Inverter output shutoff signal (MRS signal, Pr. 17)

The inverter output can be shut off from the MRS signal. The logic of the MRS signal can also be selected.

| Pr. No. | Name | Initial Value | Setting Range | Description | Parameters referred to | Refer to Section |
|---------|---------------------|---------------|---------------|--|---|------------------|
| 17 | MRS input selection | 0 | 0 | Normally open input | 178-184 Input terminal function selection | 6.10.1 |
| | | | 2 | Normally closed input (NC contact input specifications) | | |
| | | | 4 | External terminal: Normally closed input (NC contact input specifications)Communication: Normally open input | | |

The above parameter can be set when Pr. 160 "User group read selection" = 0.

Output shutoff signal

Turning on the output shutoff signal (MRS) during inverter running shuts off the output immediately.

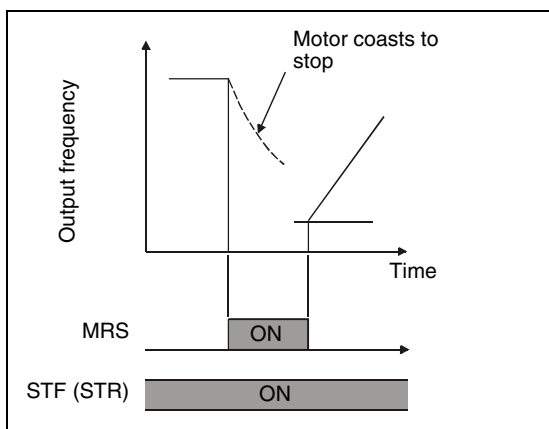

Fig. 6-51:
Output shutoff signal

1001325C

Terminal MRS may be used as described below:

- When mechanical brake (e.g. electromagnetic brake) is used to stop motor. The inverter output is shut off when the mechanical brake operates.
- To provide interlock to disable operation by the inverter. With the MRS signal on, the inverter cannot be operated if the start signal is entered into the inverter.
- Coast the motor to a stop. When the start signal is turned off, the inverter decelerates the motor to a stop in the preset deceleration time, but when the MRS signal is turned on, the motor coasts to a stop.

MRS signal logic inversion

When Pr. 17 is set to "2", the MRS signal (output stop) can be changed to the normally closed (NC contact) input specification. When the MRS signal turns on (opens), the inverter shuts off the output.

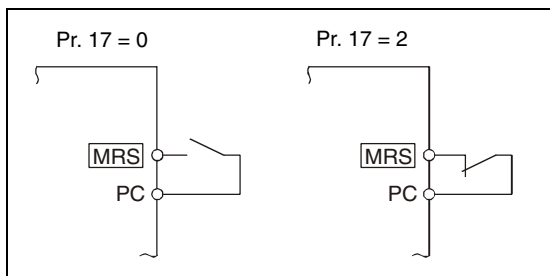

Fig. 6-52:
Connection of the MRS terminal in source logic

1000011C

Assign a different action for each MRS signal input from communication and external terminal (Pr. 17 = 4)

When Pr. 17 is set to "4", the MRS signal from external terminal (output stop) can be changed to the normally closed (NC contact) input, and the MRS signal from communication can be changed to the normally open (NO contact) input.

This function is useful to perform operation by communication with MRS signal from external terminal remained on.

| External MRS | Communication MRS | Pr. 17 | | |
|--------------|-------------------|-------------------|-------------------|-------------------|
| | | 0 | 2 | 4 |
| OFF | OFF | Operation enabled | Output shutoff | Output shutoff |
| OFF | ON | Output shutoff | Output shutoff | Output shutoff |
| ON | OFF | Output shutoff | Output shutoff | Operation enabled |
| ON | ON | Output shutoff | Operation enabled | Output shutoff |

Tab. 6-28: Activating the output shutoff by external signal or communication

NOTES

- | The MRS signal is assigned to the terminal MRS in the initial setting. By setting "24" in any of Pr. 178 to Pr.184 "Input terminal function selection", you can assign the RT signal to the other terminal.
- | The MRS signal can shut off the output, independently of the PU, external or network operation mode.
- | Changing the terminal assignment using Pr. 178 to Pr. 184 "Input terminal function selection" may affect the other functions. Make setting after confirming the function of each terminal.

6.10.3 Condition selection of function validity by second function selection signal (RT, Pr. 155)

You can select the second function using the RT signal. For the RT signal, set "3" in any of Pr. 178 to Pr. 184 "Input terminal function selection" to assign the function.

The second function has the following applications:

- Switching between normal use and emergency use.
- Switching between heavy load and light load.
- Changing of acceleration/deceleration time by broken line acceleration/deceleration.
- Switching of characteristic between main motor and sub motor.

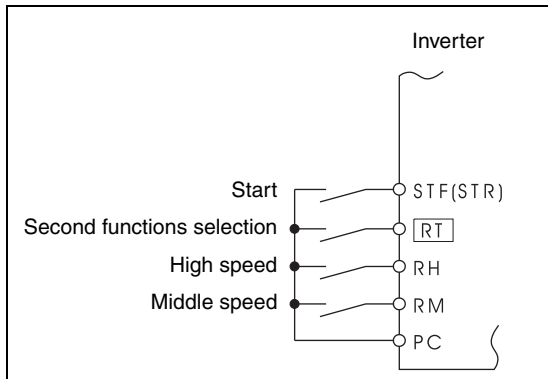

Fig. 6-53:
Second functions connection diagram

1001145C

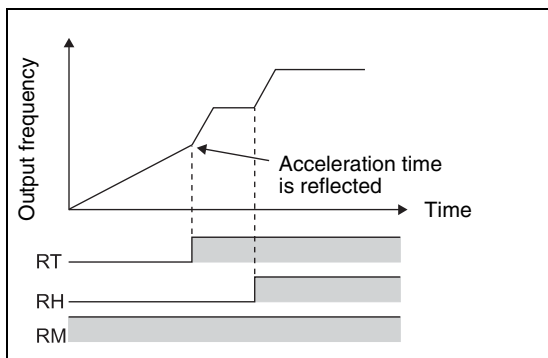

Fig. 6-54:
Second acceleration/deceleration time example

1001794E

Following functions that can be set as second functions:

| Function | Parameter Number as | | Refer to Page |
|-----------------------------------|---------------------|----------------|---------------|
| | 1. function | 2. function | |
| Torque boost | Pr. 0 | Pr. 46 | 6-33 |
| Base frequency | Pr. 3 | Pr. 47 | 6-54 |
| Acceleration time | Pr. 7 | Pr. 44 | 6-69 |
| Deceleration time | Pr. 8 | Pr. 44, Pr. 45 | 6-69 |
| Electronic thermal relay function | Pr. 9 | Pr. 51 | 6-80 |
| Stall prevention | Pr. 22 | Pr. 48 | 6-42 |
| Applied motor | Pr. 71 | Pr. 450 | 6-85 |

Tab. 6-29: Functions that can be set as second functions

NOTES

When the RT signal is on, the above second function is selected at the same time.

Changing the terminal assignment using Pr. 178 to Pr. 184 "Input terminal function selection" may affect the other functions. Make setting after confirming the function of each terminal.

6.10.4 Start signal selection (Terminal STF, STR, STOP, Pr. 250)

You can select the operation of the start signal (STF/STR).

Used to select the stopping method (deceleration to a stop or coasting) when the start signal turns off. Used to stop the motor with a mechanical brake, etc. together with switching off of the start signal. (Refer to section 6.9.3 for stop selection.)

| Pr. No. | Name | Initial Value | Setting Range | Description | | Parameters referred to | Refer to Section |
|---------|----------------|---------------|---------------|--|---|--|------------------|
| | | | | Start Signal (STF/STR) | Stop Operation | | |
| 250 | Stop selection | 9999 | 0-100s | STF: Forward rotation start STR: Reverse rotation start | The motor is coasted to a stop when the preset time elapses after the start signal is turned off. | 4-6 Multi-speed setting 178-184 Input terminal function selection | 6.6.1 6.10.1 |
| | | | 1000s - 1100s | STF: Start signal STR: Forward/reverse signal | The motor is coasted to a stop (Pr. 250 - 1000)s after the start signal is turned off. | | |
| | | | 9999 | STF: Forward rotation start STR: Reverse rotation start | When the start signal is turned off, the motor decelerates to stop. | | |
| | | | 8888 | STF: Start signal STR: Forward/reverse signal | | | |

The above parameter can be set when Pr. 160 "User group read selection" = 0.

2-wire type (terminals STF and STR)

A two-wire type connection is shown below.

In the initial setting, the forward/reverse rotation signals (STF/STR) are used as start and stop signals. Turn on either of the forward and reverse rotation signals to start the motor in the corresponding direction. If both are turned off (or on) during operation, the inverter decelerates to a stop.

The speed setting signal may either be given by entering 0 to 10V DC across the speed setting input terminal 2-5, by setting the required values in Pr. 4 to Pr. 6 "Multi-speed setting" (high, middle, low speeds), etc. (For multi-speed operation, refer to section 6.6.1).

When Pr. 250 is set to any of "1000 to 1100, 8888", the STF signal becomes a start command and the STR signal a forward/reverse command.

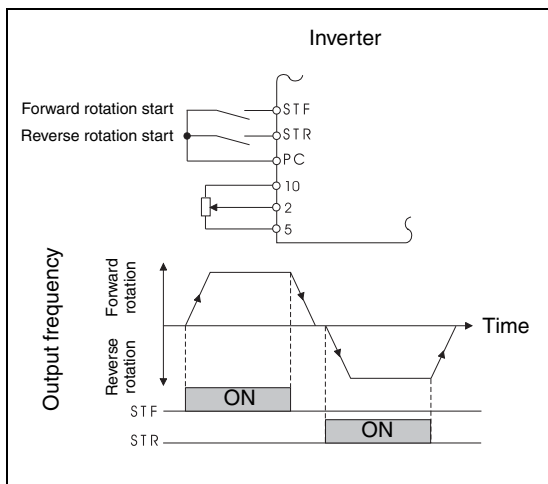

Fig. 6-55:
2-wire type connection (Pr. 250 = 9999)

1001148E

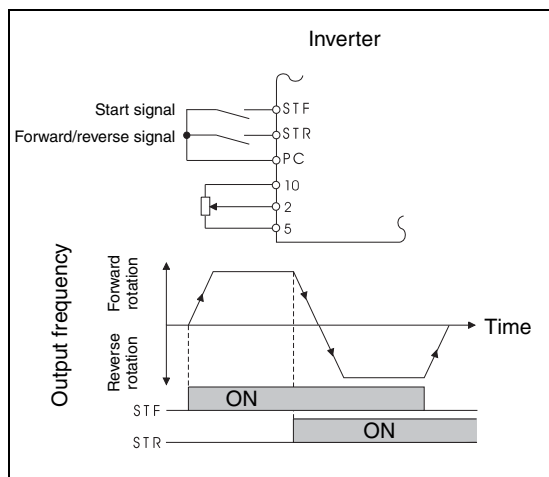

Fig. 6-56:
2-wire type connection (Pr. 250 = 8888)

I001149E

NOTES

When Pr. 250 is set to any of "0 to 100, 1000 to 1100", the motor coasts to a stop if the start command is turned off. (Refer to section 6.9.3.)

The STF and STR signals are assigned to the STF and STR terminals in the initial setting. The STF signal can be assigned to Pr. 178 "STF terminal function selection" and the STR signal to Pr. 179 "STR terminal function selection" only.

3-wire type (terminals STF, STR and STOP)

A three-wire type connection is shown below.

The start self-holding selection becomes valid when the STOP signal is turned on. In this case, the forward/reverse rotation signal functions only as a start signal.

If the start signal (STF or STR) is turned on and then off, the start signal is held and makes a start. When changing the direction of rotation, turn STR (STF) on once and then off. To stop the inverter, turning off the STOP signal once decelerates it to a stop. When using the STOP signal, set "25" in Pr. 178 to Pr. 184 to assign function.

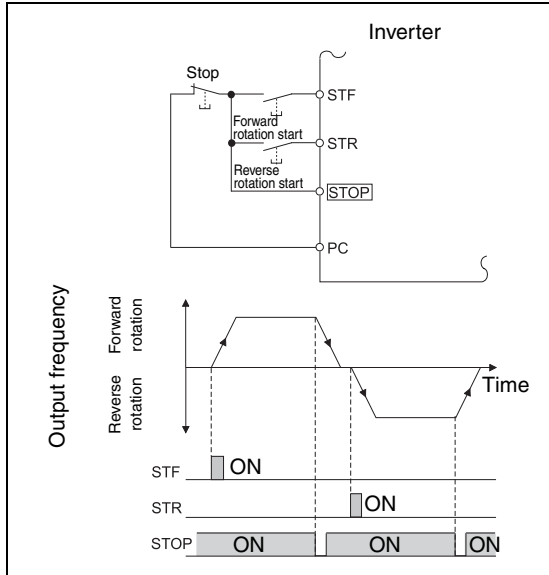

Fig. 6-57:
3-wire type connection (Pr. 250 = 9999)

I001150E

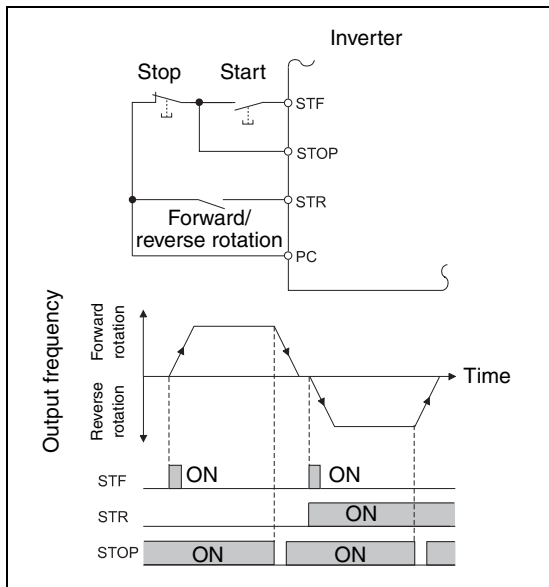

Fig. 6-58:
3-wire type connection (Pr. 250 = 8888)

I001151E

NOTES

When the JOG signal is turned on to enable jog operation, the STOP signal becomes invalid.

If the MRS signal is turned on to stop the output, the self-holding function is not cancelled.

Start signal selection

| STF | STR | Setting Inverter Status | |
|-----|-----|-------------------------|---------------------------|
| | | Pr. 250 = 0–100s/9999 | Pr. 250 = 1000–1100s/8888 |
| OFF | OFF | Stop | Stop |
| OFF | ON | Reverse rotation | |
| ON | OFF | Forward rotation | Forward rotation |
| ON | ON | Stop | Reverse rotation |

Tab. 6-30: Start signal selection

6.10.5 Output terminal function selection (Pr. 190 to Pr. 192)

You can change the functions of the open collector output terminal and relay output terminal.

| Pr. No. | Name | Initial Value | Initial Signal | Setting Range | Parameters referred to | Refer to Section |
|---------|---------------------------------|---------------|---------------------------------|---|------------------------|------------------|
| 190 | RUN terminal function selection | 0 | RUN (inverter running) | 0/1/3/4/7/8/11-16/ 20/25/26/46/47/64/ 90/91/93/95/96/98/ 99/100/101/103/ 104/107/108/ 111-116/120/125/ 126/146/147/164/ 190/191/193/195/ 196/198/199/9999 | 13 Starting frequency | 6.7.2 |
| | Open collector output terminal | | | | | |
| 191 | FU terminal function selection | 4 | FU (output frequency detection) | | | |
| 192 | ABC terminal function selection | 99 | ALM (alarm output) | 0/1/3/4/7/8/11-16/ 20/25/26/46/47/64/ 90/91/93/95/96/98/99/ 100/101/103/104/ 107/108/111-116/ 120/125/126/146/ 147/164/190/191/ 195/196/198/199/ 9999 | | |

The above parameter can be set when Pr. 160 "User group read selection" = 0.

You can set the functions of the output terminals.
Refer to the following table and set the parameters:
0-99: Source logic
100-199: Sink logic

| Setting | | Terminal | Function | Operation | Related Parameters | Refer to Page |
|--------------|------------|----------|--|---|------------------------|---------------|
| Source Logic | Sink Logic | | | | | |
| 0 | 100 | RUN | Inverter running | Output during operation when the inverter output frequency rises to or above Pr. 13 "Starting frequency". | — | 6-127 |
| 1 | 101 | SU | Up to frequency ① | Output when the output frequency is reached to the set frequency. | Pr. 41 | 6-129 |
| 3 | 103 | OL | Overload alarm | Output while stall prevention function is activated. | Pr. 22, Pr. 23, Pr. 66 | 6-42 |
| 4 | 104 | FU | Output frequency detection | Output when the output frequency reaches the frequency setting in Pr. 42 (Pr. 43 for reverse rotation). | Pr. 42, Pr. 43 | 6-129 |
| 7 | 107 | RBP | Regenerative brake prealarm | Output when 85% of the regenerative brake duty set in Pr. 70 is reached. | Pr. 70 | 6-101 |
| 8 | 108 | THP | Electronic thermal O/L relay pre-alarm | Output when the electronic thermal relay function cumulative value reaches 85%. (Electronic thermal relay function protection (E.THT/ E.THM) activates, when the value reached 100%.) | Pr. 9 | 6-84 |

Tab. 6-31: Output terminal function assignment (1)

| Setting | | Terminal | Function | Operation | Related Parameters | Refer to Page |
|--------------|------------|----------|---|---|--------------------------|---------------|
| Source Logic | Sink Logic | | | | | |
| 11 | 111 | RY | Inverter operation ready | Output when the inverter can be started by switching the start signal on or while it is running. | — | 6-127 |
| 12 | 112 | Y12 | Output current detection | Output when the output current is higher than the Pr. 150 setting for longer than the time set in Pr. 151. | Pr. 150, Pr. 151 | 6-131 |
| 13 | 113 | Y13 | Zero current detection | Output when the output power is lower than the Pr. 152 setting for longer than the time set in Pr. 153. | Pr. 152, Pr. 153 | 6-131 |
| 14 | 114 | FDN | PID lower limit | Output when the feedback value falls below the lower limit of PID control. | Pr. 127–Pr. 134 | 6-270 |
| 15 | 115 | FUP | PID upper limit | Output when the feedback value rises above the upper limit of PID control. | | |
| 16 | 116 | RL | PID forward/reverse rotation output | Output when forward rotation is performed in PID control. | | |
| 20 | 120 | BOF | Brake opening request | Output to open the brake when the brake sequence function is selected. | Pr. 278–Pr. 283, Pr. 292 | 6-109 |
| 25 | 125 | FAN | Fan fault output | Output at the time of a fan fault. | Pr. 244 | 6-295 |
| 26 | 126 | FIN | Heatsink overheat prealarm | Output when the heatsink temperature reaches about 85% of the heatsink overheat protection providing temperature. | — | 7-11 |
| 46 | 146 | Y46 | During deceleration at occurrence of power failure (retained until release) | Output when the power failure-time deceleration function is executed. | Pr. 261 | 6-162 |
| 47 | 147 | PID | During PID control activated | Output during PID control. | Pr. 127–Pr. 134 | 6-270 |
| 64 | 164 | Y64 | During retry | Output during retry processing. | Pr. 65–Pr. 69 | 6-166 |

Tab. 6-31: Output terminal function assignment (2)

| Setting | | Terminal | Function | Operation | Related Parameters | Refer to Page |
|--------------|------------|----------|--------------------------------------|--|--------------------|---------------|
| Source Logic | Sink Logic | | | | | |
| 90 | 190 | Y90 | Life alarm | Output when any of the control circuit capacitor, main circuit capacitor and inrush current limit circuit or the cooling fan approaches the end of its service life. | Pr. 255–Pr. 259 | 6-296 |
| 91 | 191 | Y91 | Alarm output 3 (power-off signal) | Output when an error occurs due to the circuit failure or connection alarm of the inverter. | — | 6-128 |
| 93 | 193 | Y93 | Current average value monitor signal | Average current value and maintenance timer value are output as pulses. The signal can not be set in Pr. 192 "ABC terminal function selection". | Pr. 555–Pr. 557 | 6-301 |
| 95 | 195 | Y95 | Maintenance timer signal | Output when Pr. 503 rises to or above the Pr. 504 setting. | Pr. 503, Pr. 504 | 6-300 |
| 96 | 196 | REM | Remote Output | Output to the terminal when a value is set to the parameter. | Pr. 495–Pr. 497 | 6-133 |
| 98 | 198 | LF | Minor fault output | Output when a minor fault (fan failure or communication error warning) occurs. | Pr. 121, Pr. 244 | 6-226, 6-295 |
| 99 | 199 | ALM | Alarm output | Output when the inverter's protective function is activated to stop the output (major fault). The signal output is stopped when a reset turns on. | — | 6-128 |
| 9999 | | — | No function | — | — | — |

Tab. 6-31: Output terminal function assignment (3)

- ① Note that when the frequency setting is varied using an analog signal or the digital dial of the operation panel, the output of the SU (up to frequency) signal may alternate on and off depending on that varying speed and the timing of the varying speed due to acceleration/deceleration time setting. (The output will not alternate on and off when the acceleration/deceleration time setting is "0s".)

NOTES

The same function may be set to more than one terminal.

When the function is executed, the terminal conducts at the setting of any of "0" to "99", and does not conduct at the setting of any of "100" to "199".

Changing the terminal assignment using Pr. 190 to Pr. 192 "Output terminal function selection" may affect the other functions. Make setting after confirming the function of each terminal.

Do not assign signals which repeat frequent ON/OFF to A, B, and C. Otherwise, the life of the relay contact decreases.

Inverter operation ready signal (RY) and inverter running signal (RUN)

When the inverter is ready to operate, the output of the operation ready signal (RY) is on. It is also on during inverter running.

When the output frequency of the inverter rises to or above Pr. 13 "Starting frequency", the output of the inverter running signal (RUN) is turned on. During an inverter stop or DC injection brake operation, the output is off.

When using the RY or RUN signal, set "11 (source logic)" or "111 (sink logic)" (RY) or "0 (source logic)" or "100 (sink logic)" (RUN) to any of Pr. 190 to Pr. 192 "Output terminal function selection" to assign the function to the output terminal.

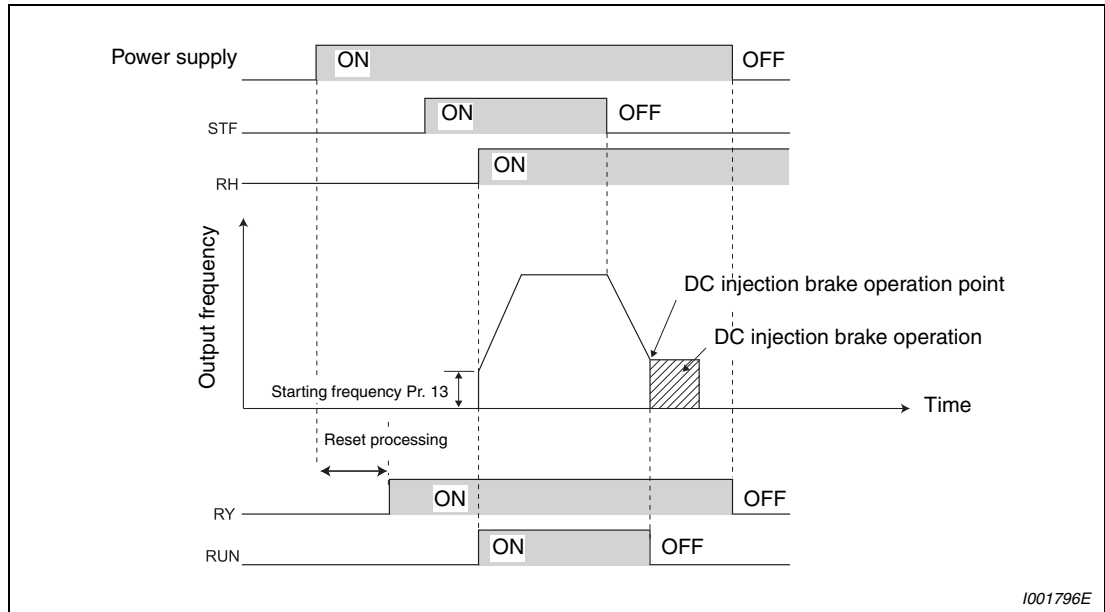

Fig. 6-59: Ready and motor running signals

| Output Signal | Start Signal OFF (during stop) | Start Signal ON (during stop) | Start Signal ON (during operation) | Under DC Injection Brake | At Alarm Occurrence or MRS Signal ON (output shutoff) | Automatic Restart after Instantaneous Power Failure | | |
|---------------|--------------------------------|-------------------------------|------------------------------------|--------------------------|---|---|------------------|------------|
| | | | | | | Coasting | | Restarting |
| | | | | | | Start Signal ON | Start Signal OFF | |
| RY | ON | ON | ON | ON | OFF | ON ① | | ON |
| RUN | OFF | OFF | ON | OFF | OFF | OFF | | ON |

Tab. 6-32: Output signal output

① This signal turns OFF during power failure or undervoltage.

NOTE

The RUN signal (positive logic) is assigned to the terminal RUN in the initial setting.

Alarm output signal (ALM)

If the inverter comes to trip, the ALM signal is output. (Refer to section 7.1.)

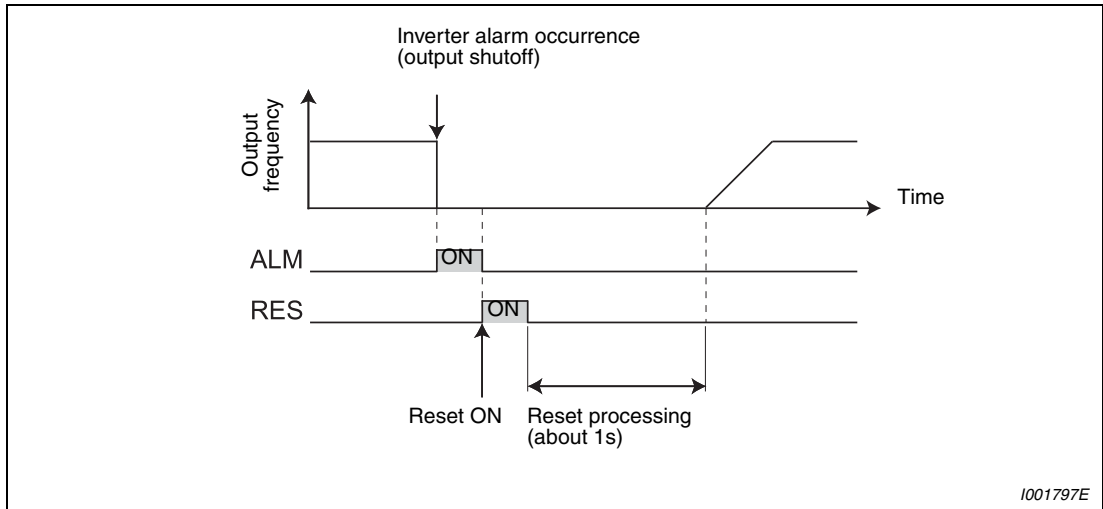

Fig. 6-60: Alarm signals

NOTE

The ALM signal is assigned to the ABC contact in the default setting. By setting "99 (positive logic) or 199 (negative logic) in Pr. 190 to Pr. 192 "Output terminal function selection", the ALM signal can be assigned to the other signal.

Fault output 3 (power-off signal) (Y91)

The Y91 signal is output at occurrence of a fault attributable to the failure of the inverter circuit or a fault caused by a wiring mistake. When using the Y91 signal, set "91 (positive logic)" or "191 (negative logic)" to any of Pr. 190 to Pr. 192 "Output terminal function selection" to assign the function to the output terminal.

| Operation Panel Indication | | Name |
|----------------------------|-------|--|
| E. bE | E.BE | Brake transistor alarm detection |
| E. GF | E.GF | Output side earth (ground) fault overcurrent |
| E. LF | E.LF | Output phase loss |
| E. PE | E.PE | Parameter storage device fault |
| EPE2 | E.PE2 | Internal board fault |
| E. 6 | E. 6/ | CPU fault |
| E. 7 | E. 7 | |
| E.CPU | E.CPU | |
| E.IOH | E.IOH | Inrush current limit circuit fault |

Tab. 6-33: Faults that lead to Y91 signal output

NOTE

At occurrence of output side earth (ground) fault overcurrent (E.GF), overcurrent trip during acceleration (E.OC1) may be displayed. At this time, the Y91 signal is output.

6.10.6 Detection of output frequency (SU, FU, Pr. 41 to Pr. 43)

The inverter output frequency is detected and output to the output signal.

| Pr. No. | Name | Initial Value | Setting Range | Description | Parameters referred to | Refer to Section |
|-----------|---|---------------|---------------|---|--|------------------|
| 41 | Up-to-frequency sensitivity | 10% | 0–100% | Set the level where the SU signal turns on. | 190–192 Output terminal function selection | 6.10.5 |
| 42 | Output frequency detection | 6Hz | 0–400Hz | Set the frequency where the FU signal turns on. | | |
| 43 | Output frequency detection for reverse rotation | 9999 | 0–400Hz | Set the frequency where the FU signal turns on in reverse rotation. | | |
| | | | 9999 | Same as Pr. 42 setting | | |

The above parameters can be set when Pr. 160 "User group read selection" = 0.

Up-to-frequency sensitivity (SU, Pr. 41)

When the output frequency reaches the set frequency, the up-to-frequency signal (SU) is output. The Pr. 41 value can be adjusted within the range 0% to $\pm 100\%$ on the assumption that the set frequency is 100%.

This parameter can be used to ensure that the running frequency has been reached to provide the operation start signal etc. for related equipment.

When using the SU signal, set "1 (positive logic) or 101 (negative logic)" in Pr. 190 to Pr. 192 "Output terminal function selection" to assign function to the output terminal.

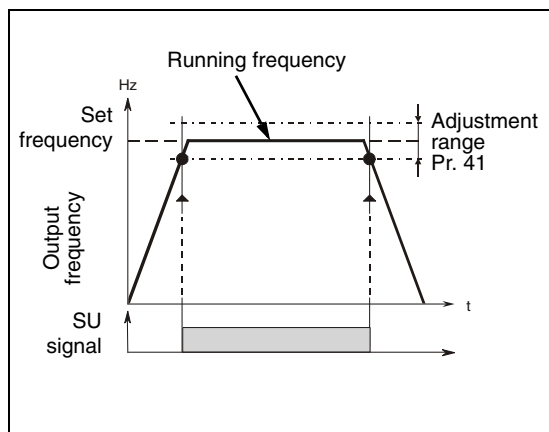

Fig. 6-61:
Output of the SU signal

1000020C

Output frequency detection (FU, Pr. 42, Pr. 43)

The output frequency detection signal (FU) is output when the output frequency reaches or exceeds the Pr. 42 setting. This function can be used for electromagnetic brake operation, open signal, etc.

When the detection frequency is set to Pr. 43, frequency detection for reverse operation use only can also be set. This function is effective for switching the timing of electromagnetic brake operation between forward rotation (rise) and reverse rotation (fall) during vertical lift operation, etc. When Pr. 43 \neq 9999, the Pr. 42 setting is used for forward rotation and the Pr. 43 setting is used for reverse rotation.

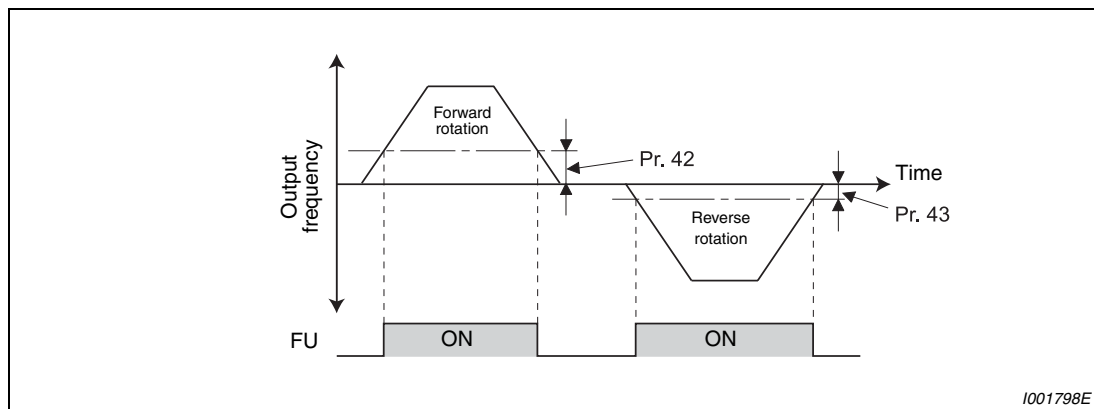

Fig. 6-62: Frequency detection for forward and reverse rotation

NOTES

The FU signal is assigned to the terminal FU in the initial setting. The FU signal can also be assigned to the other terminal by setting "4 (positive logic) or 104 (negative logic)" in any of Pr. 190 to Pr. 192.

All signals are off during DC injection brake.

The output frequency to be compared with the set frequency is the output frequency before slip compensation is performed.

Changing the terminal assignment using Pr.190 to Pr.192 "Output terminal function selection" may affect the other functions. Make setting after confirming the function of each terminal.

6.10.7 Output current detection function (Y12, Y13, Pr. 150 to Pr. 153)

The output power during inverter running can be detected and output to the output terminal.

| Pr. No. | Name | Initial Value | Setting Range | Description | Parameters referred to | Refer to Section |
|------------|--|---------------|---------------|---|--|------------------|
| 150 | Output current detection level | 150% | 0–120% | Set the output current detection level. 100% is the rated inverter current. | 190–192 Output terminal function selection | 6.10.5 |
| 151 | Output current detection signal delay time | 0s | 0–10s | Set the output current detection period. Set the time from when the output current has risen above the setting until the output current detection signal (Y12) is output. | | |
| 152 | Zero current detection level | 5% | 0–200% | Set the zero current detection level. The rated inverter current is assumed to be 100%. | | |
| 153 | Zero current detection time | 0.5s | 0–1s | Set this parameter to define the period from when the output current drops below the Pr. 152 value until the zero current detection signal (Y13) is output. | | |

The above parameters can be set when Pr. 160 "User group read selection" = 0.

Output current detection (Y12, Pr. 150, Pr. 151, Pr. 166, Pr. 167)

The output current detection function can be used for excessive torque detection, etc.

If the output current remains higher than the Pr. 150 setting during inverter operation for longer than the time set in Pr. 151, the output current detection signal (Y12) is output from the inverter's open collector or relay output terminal. When the Y12 signal turns on, the ON state is held for approximately 100ms.

For the Y12 signal, set "12 (positive logic) or 112 (negative logic)" in Pr. 190 to Pr. 192 "Output terminal function selection" and assign functions to the output terminal.

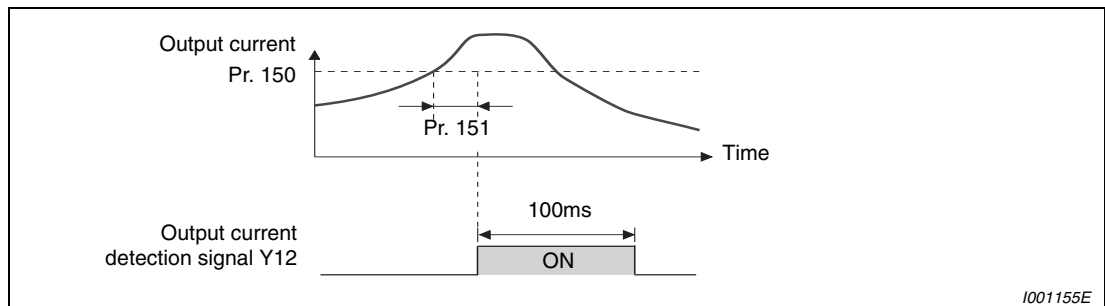

Fig. 6-63: Output current detection

Zero current detection (Y13, Pr. 152, Pr. 153)

If the output current remains lower than the Pr. 152 setting during inverter operation for longer than the time set in Pr. 153, the zero current detection (Y13) signal is output from the inverter's open collector or relay output terminal. As soon as the signal is output to terminal Y13, it remains turned on for 100ms.

When the inverter's output current falls to "0", torque will not be generated. This may cause a drop due to gravity when the inverter is used in vertical lift application. To prevent this, the output current zero signal (Y13) can be output from the inverter to close the mechanical brake when the output current has fallen to "zero".

Set "13" (source logic) or "113" (sink logic) to any of Pr. 190 to Pr. 192 "Output terminal function selection" to assign the function of the output power detection signal (Y13) to the output terminal.

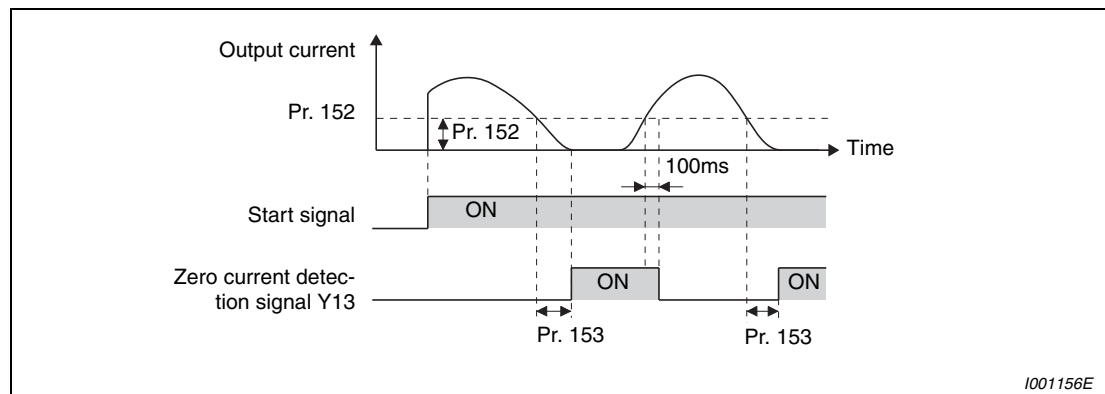

Fig. 6-64: Zero current detection

NOTES

This function is also valid during execution of the online auto tuning.

The response time of Y12 and Y13 signals is approximately 0.1s. Note that the response time changes according to the load condition.

When Pr. 152 = "0", detection is disabled.

Changing the terminal assignment using Pr. 190 to Pr. 192 "Output terminal function selection" may affect the other functions. Make setting after confirming the function of each terminal.

**CAUTION:**

The zero current detection level setting should not be too high, and the zero current detection time setting not too long. Otherwise, the detection signal may not be output when torque is not generated at a low output current.

To prevent the machine and equipment from resulting in hazardous conditions by use of the zero current detection signal, install a safety backup such as an emergency brake.

6.10.8 Remote output function (REM, Pr. 495 to Pr. 497)

You can utilize the on/off of the inverter's output signals instead of the remote output terminal of the programmable logic controller.

| Pr. No. | Name | Initial Value | Setting Range | Description | Parameters referred to | Refer to Section | |
|------------|-----------------------------------|---------------|---------------|--|--|--|--------|
| 495 | Remote output selection | 0 | 0 | Remote output data clear at powering off | Remote output data clear at inverter reset | 190–192 Output terminal function selection | 6.10.5 |
| | | | 1 | Remote output data retention at powering off | | | |
| | | | 10 | Remote output data clear at powering off | Remote output data retention at inverter reset | | |
| | | | 11 | Remote output data retention at powering off | | | |
| 496 | Remote output data 1 ^① | 0 | 0–4095 | Refer to Fig. 6-65 | | | |
| 497 | Remote output data 2 ^① | 0 | 0–4095 | | | | |

The above parameters can be set when Pr. 160 "User group read selection" = 0.

① The above parameters allow its setting to be changed during operation in any operation mode even if "0" (initial value) is set in Pr. 77 "Parameter write selection".

The output terminal can be turned on/off depending on the Pr. 496 or Pr. 497 setting. The remote output selection can be controlled on/off by computer link communication from the PU connector or by communication from the communication option.

Set "96 (positive logic) or 196 (negative logic)" to any of Pr. 190 to Pr. 192 "Output terminal function selection", and assign the remote output (REM) signal to the terminal used for remote output.

When you refer to Fig. 6-65 and set "1" to the terminal bit (terminal where the REM signal has been assigned) of Pr. 496 or Pr. 497, the output terminal turns on (off for sink logic). By setting "0", the output terminal turns off (on for sink logic).

Example ▾

When "96" (source logic) is set to Pr. 190 "RUN terminal function selection" and "1" (H01) is set to Pr. 496, the terminal RUN turns on.

△

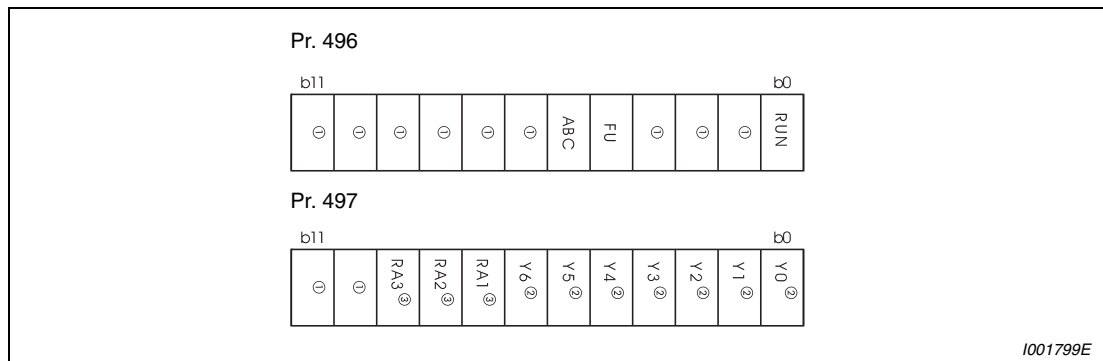

Fig. 6-65: Remote output data

- ① As desired (always "0" when read).
- ② Y0 to Y6 are available only when the extension output option (FR-A7AY E kit) is fitted.
- ③ RA1 to RA3 are available only when the relay output option (FR-A7AR E kit) is fitted.

When Pr. 495 = 0 or 10, performing a power supply reset (including a power failure) clears the REM signal output. (The ON/OFF states of the terminals are as set in Pr. 190 to Pr. 192.) The Pr. 496 and Pr. 497 settings are also "0".

When Pr. 495 = 1 or 11, the remote output data before power supply-off is stored into the E²PROM, so the signal output at power recovery is the same as before power supply-off. However, it is not stored when the inverter is reset (terminal reset, reset request through communication). (See the chart below).

When Pr. 495 = 10 or 11, signal before rest is saved even at inverter reset.

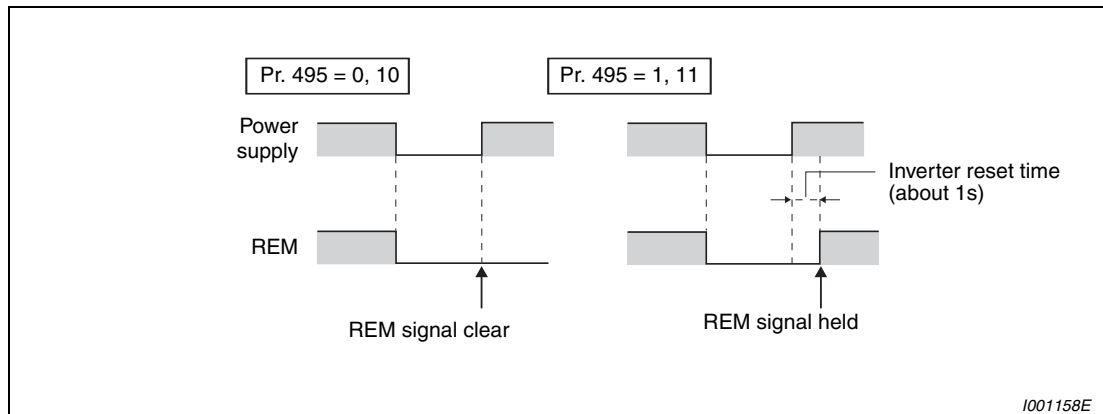

Fig. 6-66: ON/OFF example for source logic

NOTES

The output terminal where the REM signal is not assigned using any of Pr. 190 to Pr. 192 does not turn on/off if 0/1 is set to the terminal bit of Pr. 496 or Pr. 497. (It turns on/off with the assigned function.)

When the inverter is reset (terminal reset, reset request through communication), Pr. 496 and Pr. 497 values turn to "0". When Pr.495 = 1 or 11, however, they are the settings at power off. (The settings are stored at power off.) When Pr. 495 = 10 or 11, they are the same as before an inverter reset is made.

6.11 Monitor display and monitor output signals

| Purpose | Parameters that must be set | | Refer to Section |
|--|---|--|------------------|
| Display motor speed Set speed | Speed display and speed setting | Pr. 37 | 6.11.1 |
| Change PU monitor display data | DU/PU main display data selection Cumulative monitor clear | Pr. 52, Pr. 54, Pr. 170, Pr. 171, Pr. 268, Pr. 563, Pr. 564 | 6.11.2 |
| Change of the monitor output from terminal AM | Terminal AM function selection | Pr. 158 | 6.11.3 |
| Set the reference of the monitor output from terminal AM | Terminal AM standard setting | Pr. 55, Pr. 56 | 6.11.3 |
| Adjust terminal AM outputs | Terminal AM calibration | Pr. 645, Pr. 900 | 6.11.4 |

6.11.1 Speed display and speed setting (Pr. 37)

You can output RPM rates, speeds and throughput volumes based on the output frequency to the displays of the operation panels, FR-PU04 and FR-PU07 parameter units or to the AM output.

| Pr. No. | Name | Initial Setting | Setting Range | Description | Parameters referred to | Refer to Section |
|-----------|---------------|-----------------|---------------|--------------------------------|--|------------------|
| 37 | Speed display | 0 | 0 | Frequency display, setting | 1 Maximum frequency | 6.4.1 |
| | | | 0.01–9998 | Set the machine speed at 60Hz. | 52 DU/PU main display data selection 800 Control method selection | 6.11.2 6.3.2 |

The above parameters can be set when Pr. 160 "User group read selection" = 0.

The maximum value of the setting range differs according to the Pr. 1 "Maximum frequency" (Parameter 18 "High speed maximum frequency") and it can be calculated from the following formula:

$$\text{Maximum setting value of Pr. 37} < \frac{16777.215 \times 60 \text{ [Hz]}}{\text{Setting value of Pr. 1 (Pr. 18) [Hz]}}$$

Note that the maximum setting value of Pr. 37 is 9998 if the result of the above formula exceeds 9998.

To display the machine speed set Pr. 37 to the reference value for the speed to be shown at 60Hz. For example, if the speed is 55m/min at 60Hz set Pr. 37 to "55". The display will then show "55" when the motor frequency is 60Hz.

| Pr. 37 | Output Frequency Monitor | Set Frequency Monitor | Frequency Setting Parameter Setting |
|----------------------|--------------------------|-----------------------|-------------------------------------|
| 0 (initial value) | Hz | Hz | Hz |
| 0.01–9998 | Machine speed ① | Machine speed ① | |

Tab. 6-34: Setting range of parameter 37

- ① Machine speed conversion formula: $\text{Pr. 37} \times \text{frequency}/60\text{Hz}$
 ② Hz is displayed in 0.01Hz increments and machine speed is in 0.001.

NOTES

Under V/f control, the output frequency of the inverter is displayed in terms of synchronous speed, and therefore, displayed value = actual speed + motor slip. The display changes to the actual speed (estimated value calculated based on the motor slip) when advanced magnetic flux vector control was selected or slip compensation was made valid.

Refer to Pr. 52 when you want to change the PU main monitor (PU main display).

Since the panel display of the operation panel is 4 digits in length, the monitor value of more than "9999" is displayed "----".

When the machine speed is displayed on the FR-PU04/FR-PU07, do not change the speed by using an up/down key in the state where the set speed exceeding 65535 is displayed. The set speed may become arbitrary value.

While the machine speed is displayed on the monitor, values of other parameters related to speed (Pr. 1, etc.) are in frequency increments. Set other parameters (Pr. 1, etc) related to speed in increments of frequency.

Due to the limitations on the resolution of the set frequency, the indication in the second decimal place may differ from the setting.

When frequency or set frequency is monitored from network option card except for FR-A7NC E kit, frequency is displayed for monitor description regardless of Pr. 37 setting.



CAUTION:

Make sure that the running speed setting is correct. Otherwise, the motor might run at extremely high speed, damaging the machine.

6.11.2 Monitor display selection of DU/PU and terminal AM (Pr. 52, Pr. 158, Pr. 170, Pr. 171, Pr. 268, Pr. 563, Pr. 564)

The monitor to be displayed on the main screen of the control panel and parameter unit (FR-PU04/FR-PU07) can be selected.

In addition, signal to be output from the terminal AM (analog voltage output) can be selected.

| Pr. No. | Name | Initial Value | Setting Range | Description | Parameters referred to | Refer to Section |
|---------|-------------------------------------|-------------------------|--|---|--|--|
| 52 | DU/PU main display data selection ① | 0 (output frequency) | 0/5/7-12/ 14/20/ 23-25/ 52-57/61/ 62/100 | Select the monitor to be displayed on the operation panel and parameter unit. Refer to Tab. 6-35 for monitor description. | 30 Regenerative function selection 70 Special regenerative brake duty 37 Speed display 55 Frequency monitoring reference 56 Current monitoring reference | 6.9.2 6.9.2 6.11.1 6.11.3 6.11.3 |
| | | | 1-3/5/ 7-12/14/ 21/24/ 52/53/ 61/62 | Select the monitor output to terminal AM. | | |
| 170 | Watt-hour meter clear | 9999 | 0 | Set "0" to clear the watt-hour meter monitor. | | |
| | | | 10 | Set the maximum value when monitoring from communication to 0 to 9999kWh. | | |
| | | | 9999 | Set the maximum value when monitoring from communication to 0 to 65535kWh. | | |
| 171 | Operation hour meter clear | 9999 | 0/9999 | Set "0" in the parameter to clear the watt-hour monitor. Setting "9999" has no effect. | | |
| 268 | Monitor decimal digits selection ① | 9999 | 0 | Displays as integral value. | | |
| | | | 1 | Displayed in 0.1 increments. | | |
| | | | 9999 | No function | | |
| 563 | Energizing time carrying-over times | 0 | 0-65535 (reading only) | The numbers of cumulative energizing time monitor exceeded 65535h is displayed. Reading only | | |
| 564 | Operating time carrying-over times | 0 | 0-65535 (reading only) | The numbers of operation time monitor exceeded 65535h is displayed. Reading only | | |

The above parameters can be set when Pr. 160 "User group read selection" = 0.

① The above parameters allow its setting to be changed during operation in any operation mode even if "0" (initial value) is set in Pr. 77 "Parameter write selection".

Monitor description list (Pr. 52)

- Set the monitor to be displayed on the operation panel and parameter unit (FR-PU04/FR-PU07) in Pr. 52 "DU/PU main display data selection".
- Set the monitor to be output to the terminal AM (analog output (0 to 10V DC voltage output)) in Pr. 158 "AM terminal function selection".

| Types of Monitor | Unit | Pr. 52 | | Pr. 158 (AM) Setting | Terminal AM Full Scale Value | | Description |
|---|------------|---------------------|-----------------|----------------------|---------------------------------------|------|--|
| | | Operation panel LED | PU Main Monitor | | | | |
| Output frequency | 0.01Hz | 0/100 | | 1 | Pr. 55 | | Displays the inverter output frequency. |
| Output current | 0.01A/0.1A | 0/100 | | 2 | Pr. 56 | | Displays the inverter output current effective value. |
| Output voltage | 0.1V | 0/100 | | 3 | 200V class | 400V | Displays the inverter output voltage. |
| | | | | | 400V class | 800V | |
| Alarm display | — | 0/100 | | — | — | | Displays 8 past alarms individually. |
| Frequency setting | 0.01Hz | 5 | ① | 5 | Pr. 55 | | Displays the set frequency. |
| Motor torque | 0.1% | 7 | ① | 7 | Rated torque of the applied motor × 2 | | Displays the motor torque in % on the assumption that the rated motor torque is 100%. (Displays 0% during V/f control) |
| Converter output voltage | 0.1V | 8 | ① | 8 | 200V class | 400V | Displays the DC bus voltage value. |
| | | | | | 400V class | 800V | |
| Regenerative brake duty | 0.1% | 9 | ① | 9 | Pr. 70 | | Brake duty set in Pr. 30, Pr. 70 |
| Electronic thermal relay function load factor | 0.1% | 10 | ① | 10 | 100% | | Displays the motor thermal cumulative value on the assumption that the thermal operation level is 100%. ^② |
| Output current peak value | 0.01A | 11 | ① | 11 | Pr. 56 | | Holds and displays the peak value of the output power monitor. (Cleared at every start) |
| Converter output voltage peak value | 0.1V | 12 | ① | 12 | 200V class | 400V | Holds and displays the peak value of the DC bus voltage value. (Cleared at every start) |
| | | | | | 400V class | 800V | |
| Output power | 0.01kW | 14 | ① | 14 | Rated inverter power × 2 | | Displays the power on the inverter output side |
| Input terminal status | — | — | ① | — | — | | Displays the input terminal ON/OFF status on the PU. (Refer to page 6-143 for DU display.) |
| Output terminal status | — | | ① | — | — | | Displays the output terminal ON/OFF status on the PU. (Refer to page 6-143 for DU display.) |
| Cumulative energization time ^② | 1h | 20 | | — | — | | Adds up and displays the energization time after inverter shipment. You can check the numbers of the monitor value exceeded 65535h with Pr. 563. |
| Reference voltage output | — | — | | 21 | — | | Terminal AM: Output 10V |

Tab. 6-35: Monitor description list (1)

| Types of Monitor | Unit | Pr. 52 | | Pr. 158 (AM) Setting | Terminal AM Full Scale Value | Description |
|-------------------------------|-----------|---------------------|-----------------|----------------------|--------------------------------------|--|
| | | Operation panel LED | PU Main Monitor | | | |
| Actual operation time ② ③ | 1h | 23 | | — | — | Adds up and displays the inverter operation time. You can check the numbers of the monitor value exceeded 65535h with Pr. 564. Can be cleared by Pr. 171. (Refer to page 6-144.) |
| Motor load factor | 0.1% | 24 | | 24 | 200% | Displays the output current value on the assumption that the inverter rated current value is 100%. Monitor value = output power monitor value / rated inverter current × 100 [%] |
| Cumulative power ⑤ | 0.01kWh ④ | 25 | | — | — | Adds up and displays the power amount based on the output power monitor. Can be cleared by Pr. 170. (Refer to page 6-144.) |
| PID set point | 0.1% | 52 | | 52 | 100% | Display the set point, measured value and deviation during PID control. (Refer to page 6-270 for details.) |
| PID measured value | 0.1% | 53 | | 53 | 100% | |
| PID deviation value | 0.1% | 54 | | — | — | |
| Inverter I/O terminal monitor | — | 55 | — | — | — | Displays the ON/OFF status of the inverter input terminal and output terminal on the operation panel (Refer to page 6-143 for details.) |
| Option input terminal status | — | 56 | — | — | — | Displays the input terminal ON/OFF status of the digital input option (FR-A7AX E kit) on the operation panel. (Refer to page 6-143 for details.) |
| Option output terminal status | — | 57 | — | — | — | Displays the output terminal ON/OFF status of the digital output option (FR-A7AY E kit) or relay output option (FR-A7AR E kit) on the operation panel (Refer to page 6-143 for details.) |
| Motor thermal load factor | 0.1% | 61 | | 61 | Thermal relay operation level (100%) | Motor thermal heat cumulative value is displayed. (Motor overload trip (E.THM) at 100%) |
| Inverter thermal load factor | 0.1% | 62 | | 62 | Thermal relay operation level (100%) | Transistor thermal heat cumulative value is displayed. (Inverter overload trip (E.THT) at 100%) |

Tab. 6-35: Monitor description list (2)

- ① Frequency setting to output terminal status on the PU main monitor are selected by "other monitor selection" of the parameter unit (FR-PU04/FR-PU07).
- ② The cumulative energization time and actual operation time are accumulated from 0 to 65535 hours, then cleared, and accumulated again from 0. When the operation panel is used, the time is displayed up to 65.53 (65530h) on the assumption that 1h = 0.001, and thereafter, it is added up from 0.
- ③ Actual operation time is not accumulated when the cumulative operation time is less than 1h until turning off of the power supply.
- ④ When using the parameter unit (FR-PU04/FR-PU07), "kW" is displayed.
- ⑤ Since the panel display of the operation panel is 4 digits in length, the monitor value of more than "9999" is displayed "----".
- ⑥ Larger thermal value between the motor thermal and transistor thermal is displayed.
A value other than 0% is displayed if the ambient temperature (heatsink temperature) is high even when the inverter is at a stop.

NOTES

By setting "0" in Pr. 52, the monitoring of output speed to alarm display can be selected in sequence by the SET key.

When the operation panel is used, the displayed units are Hz and A only and the others are not displayed.

The monitor set in Pr. 52 is displayed in the third monitor position. However, change the output current monitor for the motor load factor.

The monitor displayed at powering on is the first monitor. Display the monitor to be displayed on the first monitor and press the SET key for 1s. (To return to the output frequency monitor, hold down the SET key for 1s after displaying the output frequency monitor.)

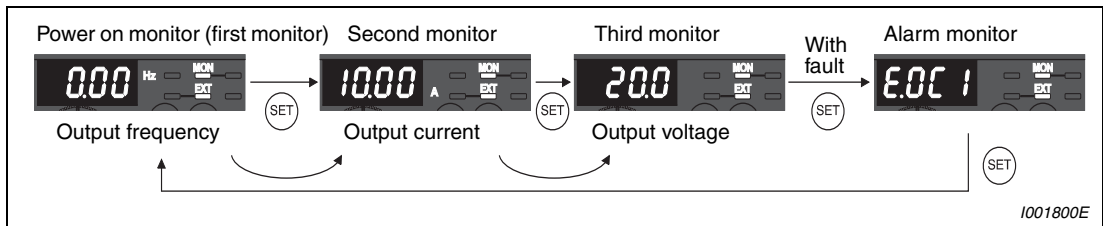

Fig. 6-67: Displaying various types of monitor

Example ▽

When Pr. 52 is set to "20" (cumulative energizing time), the monitor is displayed on the operation panel as described below.

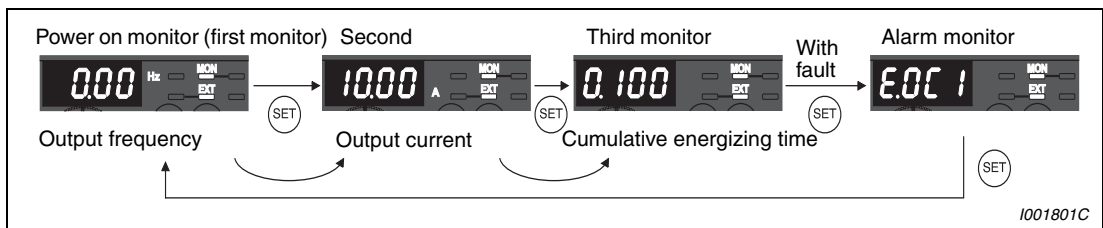

Fig. 6-68: Selection of the third monitor



Display set frequency during stop (Pr. 52)

When "100" is set in Pr. 52, the set frequency and output frequency are displayed during stop and operation respectively. (LED of Hz flickers during stop and is lit during operation.)

| | Parameter 52 | | |
|------------------|---------------------|----------------------------|------------------|
| | 0 | 100 | |
| | During running/stop | During stop | During running |
| Output frequency | Output frequency | Set frequency ^① | Output frequency |
| Output current | Output current | | |
| Output voltage | Output voltage | | |
| Alarm display | Alarm display | | |

Tab. 6-36: Display during running and stop

^① The set frequency displayed indicates the frequency to be output when the start command is on. Different from the frequency setting displayed when Pr. 52 = 5, the value based on maximum/minimum frequency and frequency jump is displayed.

NOTES

- | During an error, the output frequency at error occurrence appears.
- | During MRS, the values displayed are the same as during a stop.
- | During offline auto tuning, the tuning status monitor has priority.

Operation panel (FR-DU07) I/O terminal monitor

When Pr. 52 is set to any of "55 to 57", the I/O terminal states can be monitored on the operation panel.

The I/O terminal monitor is displayed on the third monitor.

The LED is on when the terminal is on, and the LED is off when the terminal is off. The centre line of LED is always on.

| Pr. 52 | Monitor Description |
|--------|---|
| 55 | Displays the I/O and output terminal ON/OFF states of the inverter unit. |
| 56 ① | Displays the input terminal ON/OFF states of the digital input option (FR-A7AX E kit). |
| 57 ① | Displays the output terminal ON/OFF states of the digital output option (FR-A7AY E kit) or relay output option (FR-A7AR E kit). |

Tab. 6-37: I/O terminal monitor

① You can set "56" or "57" even if the option is not fitted. When the option is not fitted, the monitor displays are all off.

On the unit I/O terminal monitor (Pr. 52 = 55), the upper LEDs denote the input terminal states and the lower the output terminal states.

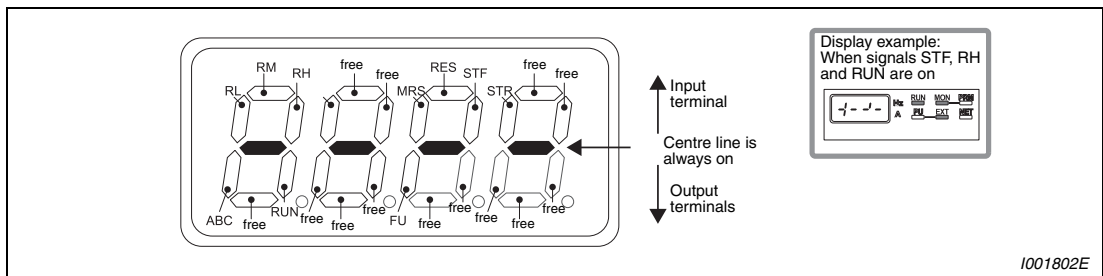

Fig. 6-69: Displaying the signal states of the I/O terminals

On the option FR-A7AX E kit monitor (Pr. 52 = 56), the decimal point LED of the first digit LED is on.

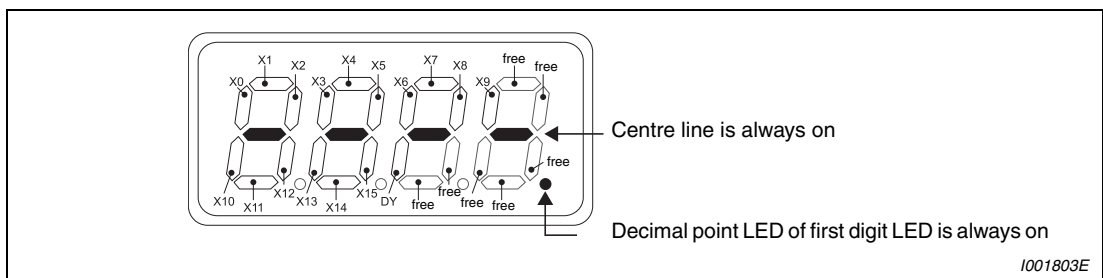

Fig. 6-70: Displaying the signal states when the option FR-A7AX E kit is mounted

On the option FR-A7AY E kit or FR-A7AR E kit monitor (Pr. 52 = 57), the decimal point LED of the second digit LED is on.

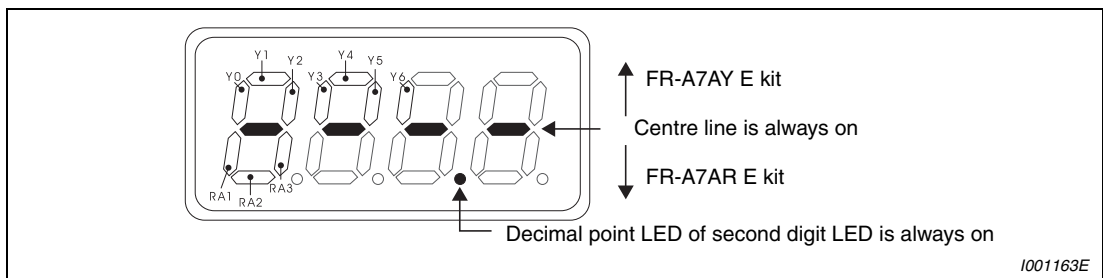

Fig. 6-71: Displaying the signal states when the option FR-A7AY E kit or FR-A7AR E kit is mounted

Cumulative energizing power monitor and clear (Pr. 170)

On the cumulative power monitor (Pr. 52 = 25), the output power monitor value is added up and is updated in 1h increments. The operation panel, parameter unit (FR-PU04/FR-PU07) and communication (RS-485 communication, communication option) display increments and display ranges are as indicated below:

| Operation Panel ① | | FR-PU04/FR-PU07 ② | | Communication | | |
|-------------------|---------|-------------------|---------|---------------|-------------------------------|------|
| Range | Unit | Range | Unit | Range | | Unit |
| | | | | Pr. 170 = 10 | Pr. 170 = 9999 | |
| 0–99.99kWh | 0.01kWh | 0–999.99kWh | 0.01kWh | 0–9999kWh | 0–65535kWh (initial value) | 1kWh |
| 100–999.9kWh | 0.1kWh | 1000–9999.9kWh | 0.1kWh | | | |
| 1000–9999kWh | 1kWh | 10000–99999kWh | 1kWh | | | |

Tab. 6-38: Units and range of the cumulative energizing monitor

- ① Power is measured in the range 0 to 9999.99kWh, and displayed in 4 digits. When the monitor value exceeds "99.99", a carry occurs, e.g. "100.0", so the value is displayed in 0.1kWh increments.
- ② Power is measured in the range 0 to 99999.99kWh, and displayed in 5 digits. When the monitor value exceeds "999.99", a carry occurs, e.g. "1000.0", so the value is displayed in 0.1kWh increments.

Writing "0" to Pr. 170 clears the cumulative energizing power monitor.

NOTE

If "0" is written to Pr. 170 and Pr. 170 is read again, "9999" or "10" is displayed.

Cumulative energizing time and actual operation time monitor (Pr. 171, Pr. 563, Pr. 564)

Cumulative energization time monitor (Pr. 52 = 20) accumulates energization time from shipment of the inverter every one hour.

On the actual operation time monitor (Pr. 52 = 23), the inverter running time is added up every hour. (Time is not added up during a stop.)

If the monitored value exceeds 65535, it is added up from 0. You can check the numbers of cumulative energization time monitor exceeded 65535h with Pr. 563 and the numbers of actual operation time monitor exceeded 65535h with Pr. 564.

Writing "0" to Pr. 171 clears the cumulative energization power monitor. (The cumulative time monitor can not be cleared.)

NOTES

The actual operation time is not added up unless the inverter is operated one or more hours continuously.

If "0" is written to Pr. 171 and Pr. 171 is read again, "9999" is always displayed. Setting "9999" does not clear the actual operation time meter.

You can select the decimal digits of the monitor (Pr. 268)

As the operation panel display is 4 digits long, the decimal places may vary at analog input, etc. The decimal places can be hidden by selecting the decimal digits. In such a case, the decimal digits can be selected by Pr. 268.

| Pr. 268 | Description |
|----------------------|--|
| 9999 (initial value) | No function |
| 0 | For the first or second decimal places (0.1 increments or 0.01 increments) of the monitor, numbers in the first decimal place and smaller are rounded to display an integral value (1 increments). The monitor value smaller than 0.99 is displayed as 0. |
| 1 | When 2 decimal places (0.01 increments) are monitored, the 0.01 decimal place is dropped and the monitor displays the first decimal place (0.1 increments). The monitored digits in 1 increments are displayed as they are. |

Tab. 6-39: Selection of decimal digits

NOTE

The number of display digits on the cumulative energization time (Pr. 52 = 20) and actual operation time (Pr. 52 = 23) does not change.

6.11.3 Reference of the terminal AM (analog voltage output) (Pr. 55, Pr. 56)

Analog voltage output from the terminal AM is available. Set the reference of the signal output from terminal AM.

| Pr. No. | Name | Initial Value | Setting Range | Description | Parameters referred to | Refer to Section |
|-----------|---|-------------------------------|---------------|---|------------------------------------|------------------|
| 55 | Frequency monitoring reference ^① | 50Hz | 0-400Hz | Full-scale value to output the output frequency monitor value to terminal AM. | 158 AM terminal function selection | 6.11.2 |
| 56 | Current monitoring reference ^① | Rated inverter output current | 0-500A | Full-scale value to output the output current monitor value to terminal AM. | | |

The above parameters can be set when Pr. 160 "User group read selection" = 0.

① The above parameters allow its setting to be changed during operation in any operation mode even if "0" (initial value) is set in Pr. 77 "Parameter write selection".

Frequency monitoring reference (Pr. 55)

Set the frequency to be referenced when the frequency monitor (output frequency/set frequency) is selected for the terminal AM display.

- Set the frequency (output frequency/set frequency) when the voltage output at terminal AM is 10V DC. The analog voltage output and frequency at terminal AM are proportional. (The maximum output voltage is 10V DC.).

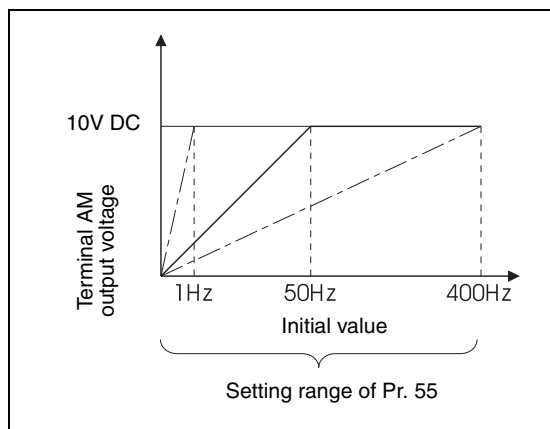

Fig. 6-72:
Frequency monitoring reference

1001164E

Current monitoring reference (Pr. 56)

Set the current to be referenced when the current monitor (inverter output current, etc.) is selected for terminal AM display.

- Set the current value when the voltage output at terminal AM is 10V DC. The analog voltage output and current value at terminal AM are proportional. (The maximum output voltage is 10V DC.)

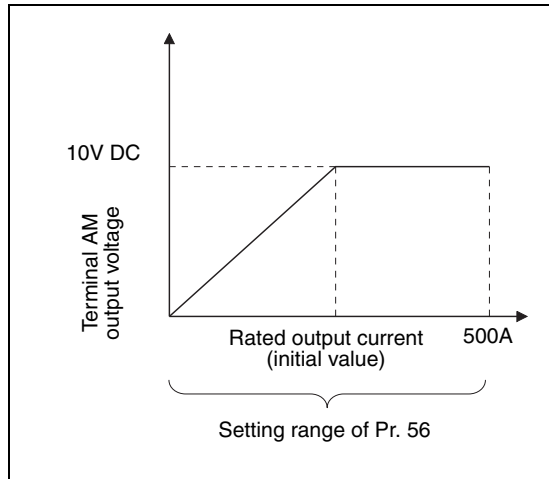

Fig. 6-73:
Current monitoring reference

I001165E

6.11.4 Terminal AM calibration [calibration parameter Pr. 645, C1 (Pr.901)]

By using the operation panel or parameter unit, you can calibrate terminal AM to full scale deflection.

| Pr. No. | Name | Initial Value | Setting Range | Description | Parameters referred to | Refer to Section |
|-----------------|-------------------------|---------------|---------------|---|---|------------------|
| 645 | AM 0V adjustment | 1000 | 970-1200 | Calibrates the scale of the meter when analog output is 0. | 55 Frequency monitoring reference | 6.11.3 |
| C1 (901) | AM terminal calibration | — | — | Calibrates the scale of the meter connected to terminal AM. | 56 Current monitoring reference 158 AM terminal function selection | 6.11.3 |

The above parameters can be set when Pr. 160 "User group read selection" = 0.

The parameter number in parentheses is the one for use with the operation panel (PA02) for the FR-E500 series or parameter unit (FR-PU04/FR-PU07).

The above parameters allow its setting to be changed during operation in any operation mode even if "0" (initial value) is set in Pr. 77 "Parameter write selection".

Terminal AM bias calibration

Use Pr. 645 AM "0V adjustment" to calibrate the bias side output signal from terminal AM. If the meter needle does not point to 0 when the analog output from terminal AM is 0, add or decrease the Pr. 645 setting to adjust the meter needle points to 0. When changing ± 1 in Pr. 645, the analog output changes about $\pm 5\text{mV}$. (Analog output will not become lower than about -100mV even when setting the Pr. 645 lower.)

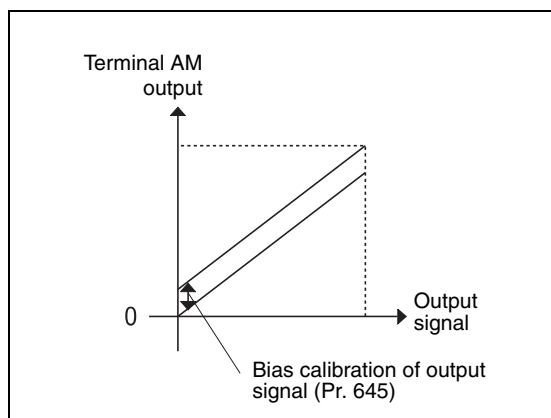

Fig. 6-74:
Terminal AM bias calibration

1001931E

NOTES

Calibration bias and gain changes when changing the control circuit terminal block. Use Pr. 645 and C1 (Pr. 901) to calibrate again in that case.

If bias calibration (Pr. 645) is performed, make sure to perform gain calibration (C1 (Pr. 901)) too.

Terminal AM gain calibration [C1 (Pr. 901)]

Terminal AM is factory-set to provide a 10V DC output in the full-scale status of the corresponding monitor item. Calibration parameter C1 (Pr. 901) allows the output voltage ratios (gains) to be adjusted according to the meter scale. Note that the maximum output voltage is 10V DC, the maximum output current 1mA.

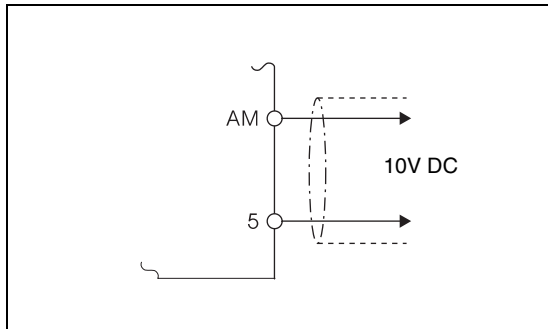
**Fig. 6-75:**

Connecting an analog meter to the AM output

I001168C

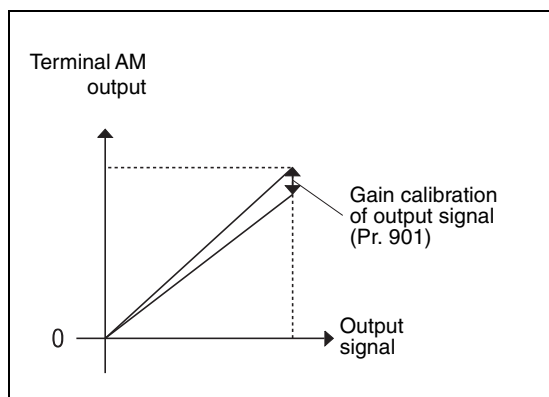
**Fig. 6-76:**

Terminal AM gain calibration

I001932E

Calibrate the terminal AM gain in the following procedure:

- ① Connect an 0–10V DC voltmeter to inverter terminals AM and 5, taking care to correct with the correct polarity. AM is positive.
- ② Set Pr. 158 to select the monitor signal you want to output to analog output AM (refer to page 6-146). To display the output frequency or the output current set Pr. 55 or Pr. 56, respectively, to the maximum frequency or current value for which you want to output 10V to the terminal.
- ③ Start the frequency inverter in PU mode with the operation panel or the control terminals (external operation).
- ④ Calibrate the full deflection of the meter by setting C1 (Pr. 901) and then operating the digital dial. Note that the value shown on the operating panel for the monitor signal associated with C1 does not change when you turn the digital dial, but the analog voltage output to AM will change as you turn the dial. Confirm the calibration value found by pressing the SET key (this assigns the maximum voltage output to the displayed value of the monitor signal.)

NOTE

If it is not possible output the signal to be measured for calibration at its maximum value you can set Pr. 158 to "21". This outputs a continuous signal of approx. 10V to terminal AM, which makes it possible to calibrate the maximum value on the meter. When C1 is used to calibrate the full meter deflection in this mode a value of "1000" is displayed. Afterwards you can then reset Pr. 158 to the required monitor signal setting.

How to calibrate the terminal AM when using the operation panel

The following example shows how to calibrate the maximum value of the AM terminal to the 60Hz output frequency. This operation is performed in PU mode.

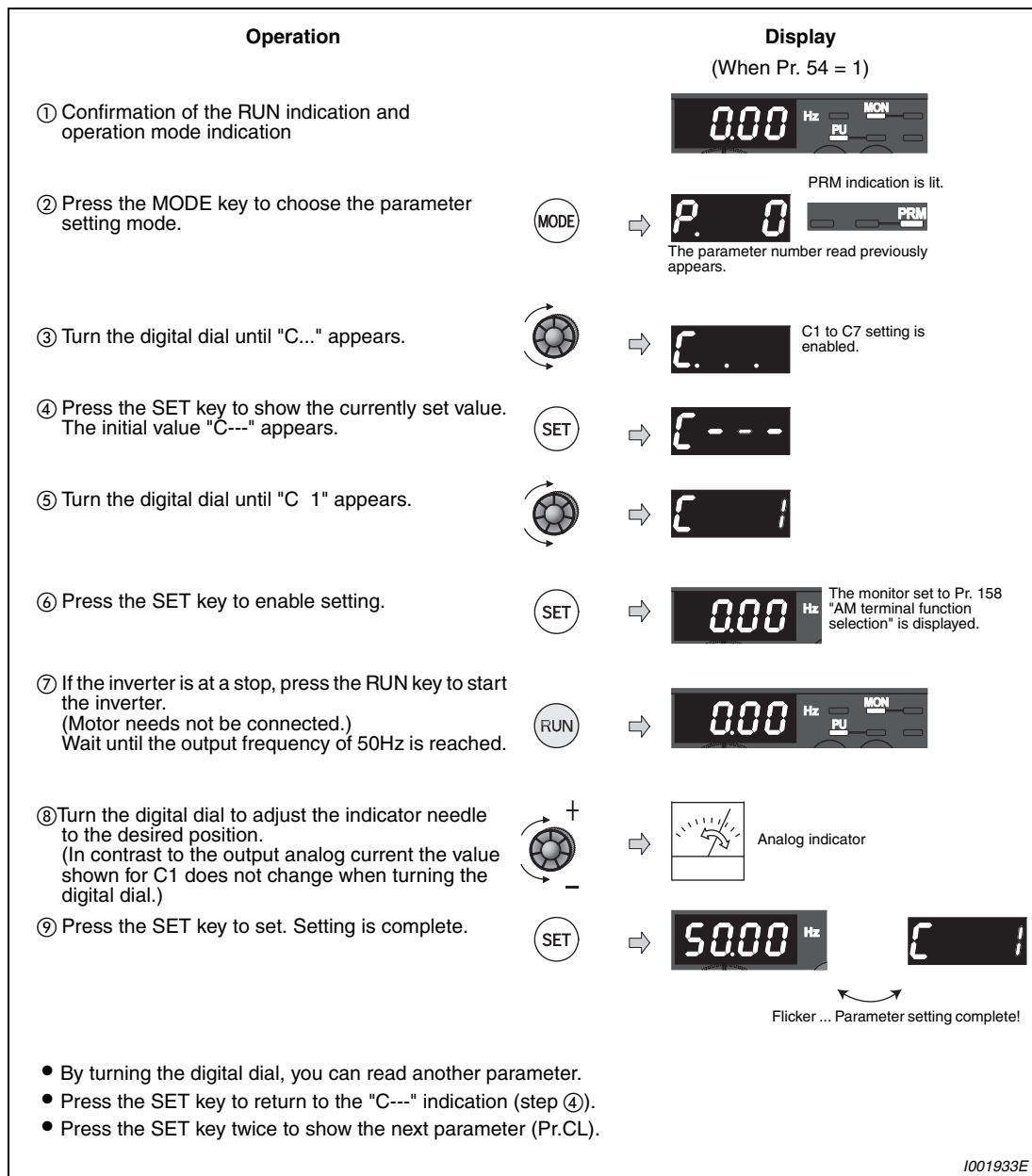

Fig. 6-77: AM terminal calibration

NOTES

- Calibration can also be made for external operation. Set the frequency in external operation mode, and make calibration in the above procedure.
- Calibration can be made even during operation.
- For the operation procedure using the parameter unit (FR-PU04/FR-PU07), refer to the parameter unit instruction manual.

6.12 Operation selection at power failure

| Purpose | Parameters that must be set | | Refer to Section |
|--|--|---|------------------|
| At instantaneous power failure occurrence, restart inverter without stopping motor. | Automatic restart operation after instantaneous power failure/flying start | Pr. 30, Pr. 57, Pr. 58, Pr. Pr. 96, Pr. 162, Pr. 165, Pr. 298, Pr. 299, Pr. 611 | 6.12.1 |
| When under voltage or a power failure occurs, the inverter can be decelerated to a stop. | Power failure-time deceleration-to-stop function | Pr. 261 | 6.12.2 |

6.12.1 Automatic restart (Pr. 30, Pr. 57, Pr. 58, Pr. 96, Pr. 162, Pr. 165, Pr. 298, Pr. 299, Pr. 611)

You can restart the inverter without stopping the motor in the following cases.

- when power comes back on after an instantaneous power failure
- when motor is coasting at start

| Pr. No. | Name | Initial Value | Setting Range | Description | Parameters referred to | Refer to Section |
|------------|---|---------------|---------------|---|---|--|
| 30 | Regenerative function selection | 0 | 0/1 | The motor starts at the starting frequency when MRS (X10) turns on then off. | 7 Acceleration time 21 Acceleration/ deceleration time increments | 6.7.1 6.7.1 |
| | | | 2 | Restart operation is performed when MRS (X10) turns on then off | | |
| 57 | Restart coasting time | 9999 | 0 | FR-E720S-080 or less, FR-E740-040 or less 1 s FR-E720S-110, FR-E740-060 to 170..... 2 s FR-E740-230 and 300..... 3 s | 13 Starting frequency 65 Retry selection 67-69 Retry function 71 Applied motor 78 Reverse rotation prevention selection | 6.7.2 6.13.1 6.13.1 6.8.2 6.17.3 |
| | | | 0.1-5s | Set the waiting time for inverter-triggered restart after an instantaneous power failure. | | |
| | | | 9999 | No restart | | |
| 58 | Restart cushion time | 1s | 0-60s | Set a voltage starting time at restart. | 178-184 Input terminal function selection | 6.10.1 |
| 96 | Auto tuning setting/status | 0 | 0 | Offline auto tuning is not performed | | |
| | | | 1 | Advanced magnetic flux vector control Offline auto tuning is performed without motor running (all motor constants) (Refer to section 6.3.2.) | | |
| | | | 11 | For general-purpose magnetic flux vector control Offline auto tuning is performed without motor running (motor constants (R1) only) (Refer to section 6.3.3.) | | |
| | | | 21 | Offline auto tuning (tuning performed without motor running) for V/f control and automatic restart after instantaneous power failure (with frequency search) | | |
| 162 | Automatic restart after instantaneous power failure selection | 0 | 0 | With frequency search | | |
| | | | 1 | No frequency search: The output voltage is increased until the preset frequency is reached, irrespective of the current motor speed. | | |
| | | | 10 | Frequency search at every start | | |
| | | | 11 | On every start the output voltage is increased until the preset frequency reached, irrespective of the current motor speed. | | |
| 165 | Stall prevention operation level for restart | 150% | 0-200% | Consider the rated inverter current according to the overload capacity as 100% and set the stall prevention operation level during restart operation. | | |
| 298 | Frequency search gain | 9999 | 0-32767 | When offline auto tuning is performed under V/f control, frequency search gain necessary for frequency search for automatic restart after instantaneous power failure is set as well as the motor constants (R1). | | |
| | | | 9999 | Uses the Mitsubishi motor (SF-JR, SF-HR, SF-JRCA, SF-HRCA) constants | | |
| 299 | Rotation direction detection selection at restarting | 9999 | 0 | Without rotation direction detection | | |
| | | | 1 | With rotation direction detection | | |
| | | | 9999 | When Pr. 78 = "0", the rotation direction is detected. When Pr. 78 = "1", "2", the rotation direction is not detected. | | |
| 611 | Acceleration time at a restart | 9999 | 0-3600s | Acceleration time to reach the acceleration time reference frequency at a restart. | | |
| | | | 9999 | Acceleration time for restart is the normal acceleration time (e.g. Pr. 7) | | |

The above parameters can be set when Pr. 160 "User group read selection" = 0.

Automatic restart after instantaneous power failure operation (Pr. 30, Pr. 162, Pr. 299)

● Without frequency search

When Pr. 162 = "1" or "11", automatic restart operation is performed in a reduced voltage system, where the voltage is gradually risen with the output frequency unchanged from prior to an instantaneous power failure independently of the coasting speed of the motor.

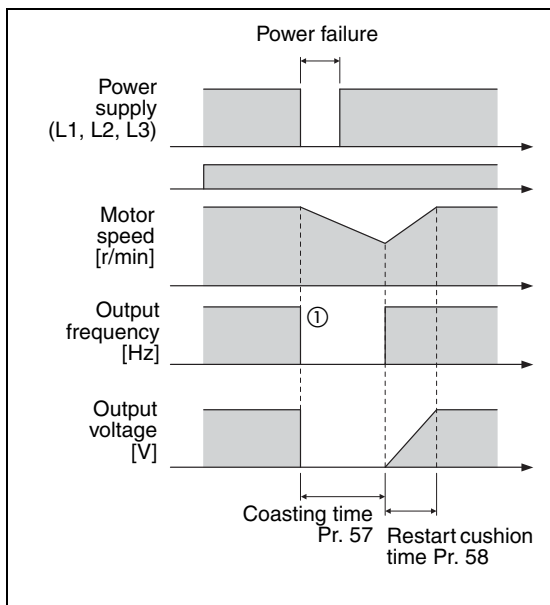

Fig. 6-78:
Automatic restart without frequency search
(Pr. 162 = 1/11)

I001901E

① The output shut off timing differs according to the load condition.

NOTE

This system stores the output frequency and rotation direction prior to an instantaneous power failure and restart using the stored value. Therefore, if the instantaneous power failure time exceeds 0.2s and the stored value cannot be retained, the inverter starts at Pr. 13 "Starting frequency" (initial value = 0.5Hz) in the starting direction upon power restoration.

● With frequency search

When "0 (initial value) or 10" is set in Pr. 162, the inverter smoothly starts after detecting the motor speed upon power restoration. (The motor capacity should be equal to or one rank lower than the inverter capacity.)

When using the frequency search, perform offline autotuning. (Refer to page 6-88 for advanced magnetic flux vector, general-purpose magnetic flux vector control and page 6-157 for V/f control.)

During reverse rotation, the inverter can be restarted smoothly as the direction of rotation is detected. You can select whether to make rotation direction detection or not with Pr. 299 "Rotation direction detection selection at restarting". When capacities of the motor and inverter differ, set "0" (without rotation direction detection) in Pr. 299.

| Pr. 299 Setting | Pr. 78 Setting | | |
|-------------------------|--------------------------------------|--------------------------------------|--------------------------------------|
| | 0 | 1 | 2 |
| 9999 (Initial value) | With rotation direction detection | Without rotation direction detection | Without rotation direction detection |
| 0 | Without rotation direction detection | Without rotation direction detection | Without rotation direction detection |
| 1 | With rotation direction detection | With rotation direction detection | With rotation direction detection |

Tab. 6-40: Rotation direction direction

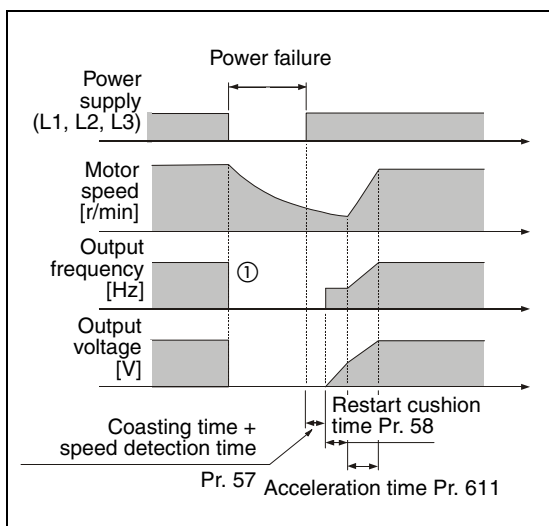

Fig. 6-79: Automatic restart with frequency search (Pr. 162 = 0/10)

① The output shut off timing differs according to the load condition.

1000722C

NOTES

Speed detection time (frequency search) changes according to the motor speed (maximum 100ms).

Frequency search errors can occur if the output capacity of the frequency inverter is one or more classes higher than that of the motor or if the motor is a special model (e.g. with a frequency rating above 60Hz). If this happens it is possible for over current error messages (OCT) to be generated during motor acceleration. In such configurations flying restarts are not possible and the frequency search function should not be used.

At motor frequencies of 10Hz or less the inverter accelerates from 0Hz to the set frequency.

If more than one motor is connected to the inverter in parallel the frequency search on automatic restart does not work correctly and over current error messages (OCT) are likely. In such configurations deactivate frequency search (set Pr. 162 to "1" or "11").

When reverse rotation is detected when Pr. 78 = 1 (reverse rotation disabled), the rotation direction is changed to forward rotation after decelerates in reverse rotation when the start command is forward rotation. The inverter will not start when the start command is reverse rotation.

When automatic restart operation after instantaneous power failure is activated while the motor is running at a low speed (less than 10Hz), the motor restarts in the direction prior to instantaneous power failure without detecting the rotation direction (Pr. 299 "Rotation direction detection selection at restarting" = 1).

If the frequency search result exceeds the set frequency, the output frequency is limited at the set frequency.

When the wiring length exceeds 100m, select without frequency search (Pr. 162 = 1 or 11).

- Restart operation at every start
When Pr. 162 = "10" or "11", automatic restart operation is also performed every start, in addition to the automatic restart after instantaneous power failure. When Pr. 162 = "0", automatic restart operation is performed at the first start after power supply-on, but not performed at the second time or later.
- Automatic restart operation selection of MRS (X10) signal
Restart operation after turning MRS (X10) signal on then off using Pr. 30 can be selected as in the table below. When automatic restart after instantaneous power failure is selected when using the high power factor converter (FR-HC), normally set "2" in Pr. 30.

| Pr. 30 | Operation after MRS and X10 Signal Turns off, on, then off |
|--------|--|
| 0/1 | Start at the Pr. 13 "Starting frequency". |
| 2 | Frequency search is made and starts at the coasting speed. |

Restart coasting time (Pr. 57)

Coasting time is the time from when the motor speed is detected until automatic restart control is started.

Set Pr. 57 to "0" to perform automatic restart operation.

The coasting time is automatically set to the value below. Generally this setting will pose no problems.

- FR-E720S-080 or less, FR-E740-040 or less 1s/
- FR-E720S-100, FR-E740-060 to 170 2s/
- FR-E740-230 and 300 3s

Operation may not be performed well depending on the magnitude of the moment of inertia (J) of the load or running frequency. Adjust the coasting time between 0.1s and 5s according to the load specifications.

Restart cushion time (Pr. 58)

Cushion time is the length of time when the voltage appropriate to the voltage at the detected motor speed (output frequency prior to instantaneous power failure when Pr. 162 = 1 or 11) from 0V.

Normally the initial value need not be changed for operation, but adjust it according to the magnitude of the moment of inertia (J) of the load or torque.

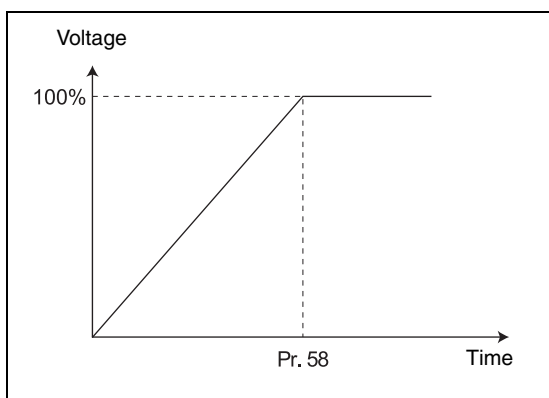

Fig. 6-80:
Voltage rise at automatic restart

1001170E

Automatic restart operation adjustment (Pr. 165, Pr. 611)

Using Pr. 165, you can set the stall prevention operation level at a restart.

Using Pr. 611, you can set the acceleration time until the set frequency (Pr. 20) is reached after automatic restart operation is performed besides the normal acceleration time.

NOTE

If the setting of Pr. 21 "Acceleration/deceleration time increments" is changed, the setting increments of Pr. 611 does not change.

Frequency search gain (Pr. 298), offline auto tuning (Pr. 96)

When automatic restart after instantaneous power failure operation (with frequency search) is valid at V/f control, perform offline auto tuning. Perform offline auto tuning during V/f control in the following order to set Pr. 298 "Frequency search gain" automatically. (Refer to page 6-88 during advanced magnetic flux vector control and general-purpose magnetic flux vector control.)

Before performing offline auto tuning

Check the following before performing offline auto tuning:

- The inverter is under V/f control.
- A motor should be connected. Note that the motor should be at a stop at a tuning start.
- The motor capacity should be equal to or one rank lower than the inverter capacity.
- The maximum frequency is 120Hz.
- A high-slip motor, high-speed motor and special motor cannot be tuned.
- Even if tuning is performed without motor running (Pr. 96 "Auto tuning setting/status" = 21), the motor may run slightly. Therefore, fix the motor securely with a mechanical brake, or before tuning, make sure that there will be no problem in safety if the motor runs (caution is required especially in vertical lift applications). Note that tuning performance is unaffected even if the motor runs slightly.
- Offline auto tuning will not be performed properly if it is performed with a surge voltage suppression filter (FFR-DT) connected between the inverter and motor. Remove it before starting tuning.

Setting

- Set "21" in Pr. 96 "Auto tuning setting/status". Tuning is performed without motor running. According to the motor type and the inverter capacity, it takes approximately 9s until tuning is completed. (Excitation noise is produced during tuning.)
- Set the rated motor current (initial value is rated inverter current) in Pr. 9 "Electronic thermal O/L relay". (Refer to section 6.8).
- Set Pr. 71 "Applied motor" according to the motor used.

| Motor | | Pr. 71 ^① |
|--|------------------------|---------------------|
| Mitsubishi standard motor, Mitsubishi high efficiency motor | SF-JR | 3 |
| | SF-JR 4P-1.5kW or less | 23 |
| | SF-HR | 43 |
| | Others | 3 |
| Mitsubishi constant-torque motor | SF-JRCA 4P | 13 |
| | SF-HRCA | 53 |
| | Others (SF-JRC, etc.) | 13 |
| Other manufacturer's standard motor | — | 3 |
| Other manufacturer's constant torque motor | — | 13 |

Tab. 6-41: Motor selection

^① Refer to section 6.8.2, for other settings of Pr. 71.

Execution of tuning**CAUTION:**

Before performing tuning, check the monitor display of the operation panel or parameter unit (FR-PU04/FR-PU07) if the inverter is in the status for tuning. (Refer to Tab. 6-13).

When performing tuning or PU operation, press the RUN key of the operation panel.

For external operation, turn on the run command (STF signal or STR signal). Tuning starts.

NOTES

To force tuning to end, use the MRS or RES signal or press the STOP key of the operation panel. (Turning the start signal (STF signal or STR signal) off also ends tuning.)

During offline auto tuning, only the following I/O signals are valid: (initial value)

- Input terminal <valid signal> MRS, RES, STF, STR
- Output terminal RUN, AM, A, B, C

Note that the progress status of offline auto tuning is output from AM when speed and output frequency are selected.

Since the RUN signal turns on when tuning is started, caution is required especially when a sequence which releases a mechanical brake by the RUN signal has been designed.

When executing offline auto tuning, input the run command after switching on the main circuit power (R/L1, S/L2, T/L3) of the inverter.

Do not perform ON/OFF switching of the second function selection signal (RT) during execution of offline auto tuning. Auto tuning is not executed properly.

Monitor display during auto tuning

Monitor is displayed on the operation panel and parameter unit (FR-PU04/FR-PU07) during tuning as below.

| | Parameter Unit (FR-PU04/FR-PU07) Display | Operation Panel Indication |
|--|---|----------------------------|
| Parameter 96 | 21 | 21 |
| Setting | | |
| Tuning in progress | | |
| Normal end | | |
| Error end (when inverter protective function operation is activated) | | |

Tab. 6-42: Monitor display

| Offline Auto Tuning Setting | Time |
|--|--|
| Tune motor constants (R1) only (Pr. 96 = 21) | Approx. 9s (Tuning time differs according to the inverter capacity and motor type.) |

Tab. 6-43: Offline auto tuning time (when the initial value is set)

Return to the normal operation mode

When offline auto tuning ends, press the STOP/RESET key of the operation panel during PU operation.

For external operation, turn off the start signal (STF signal or STR signal) once.

This operation resets the offline auto tuning and the PU's monitor display returns to the normal indication. (Without this operation, next operation cannot be started.)

NOTE

Do not change the Pr. 96 setting after completion of tuning (23). If the Pr. 96 setting is changed, tuning data is made invalid. If the Pr. 96 setting is changed, tuning must be performed again.

If offline auto tuning ended in error (see the table below), motor constants are not set. Perform an inverter reset and restart tuning.

| Error Display | Error cause | Remedy |
|---------------|--|--|
| 8 | Force end | Set "21" in Pr. 96 and perform tuning again. |
| 9 | Inverter protective function operation | Make setting again. |
| 91 | Current limit (stall prevention) function was activated. | Set "1" in Pr. 156. |
| 92 | Converter output voltage reached 75% of rated value. | Check for fluctuation of power supply voltage. |
| 93 | – Calculation error – A motor is not connected. | Check the motor wiring and make setting again. Set the rated current of the motor in Pr. 9. |

Tab. 6-44: Value of Parameter 96

When tuning is ended forcibly by pressing the STOP-key or turning off the start signal (STF or STR) during tuning, offline auto tuning does not end normally. (The motor constants have not been set.) Perform an inverter reset and restart tuning.

When using the motor corresponding to the following specifications and conditions, reset Pr.9 Electronic thermal O/L relay as below after tuning is completed.

- When the rated power specifications of the motor is 200/220V(400/440V) 60Hz, set 1.1 times rated motor current value in Pr. 9.
- When performing motor protection from overheat using a PTC thermistor or motor with temperature detector such as Klixon, set "0" (motor overheat protection by the inverter is invalid) in Pr. 9.

NOTES

The motor constants measured once in the offline auto tuning are stored as parameters and their data are held until the offline auto tuning is performed again.

An instantaneous power failure occurring during tuning will result in a tuning error. After power is restored, the inverter goes into the normal operation mode. Therefore, when STF (STR) signal is on, the motor runs in the forward (reverse) rotation.

Any alarm occurring during tuning is handled as in the ordinary mode. Note that if an error retry has been set, retry is ignored.

The set frequency monitor displayed during the offline auto tuning is 0Hz.

Changing the terminal assignment using Pr. 178 to Pr. 184 "Input terminal function selection" may affect the other functions. Make setting after confirming the function of each terminal.

The SU and FU signals are not output during a restart. They are output after the restart cushion time has elapsed.

Automatic restart operation will also be performed after a reset or when a retry is made by the retry function.

**CAUTION:**

Before activating the automatic restart after power failure function please make sure that this mode is supported for the drive and permitted for your configuration.

When automatic restart after instantaneous power failure has been selected, the motor and machine will start suddenly (after the reset time has elapsed) after occurrence of an instantaneous power failure. Stay away from the motor and machine. When you have selected automatic restart after instantaneous power failure function, apply CAUTION stickers in easily visible places.

When the start signal is turned off or is pressed during the restart cushion time after instantaneous power failure, deceleration starts after Pr. 58 "Restart cushion time" has elapsed.

6.12.2 Power failure-time deceleration-to-stop function (Pr. 261)

When a power failure or under voltage occurs, the inverter can be decelerated to a stop or can be decelerated and re-accelerated to the set frequency.

| Pr. No. | Name | Initial Value | Setting Range | Description | Parameters referred to | Refer to Section |
|---------|------------------------------|---------------|---------------|--|--|------------------|
| 261 | Power failure stop selection | 0 | 0 | Coasting to stop when under voltage or power failure occurs, the inverter output is shut off. | 57 Restart coasting time 190-192 Output terminal function selection | 6.12.1 6.10.5 |
| | | | 1 | When under voltage or a power failure occurs, the inverter can be decelerated to a stop. | | |
| | | | 2 | When under voltage or a power failure occurs, the inverter can be decelerated to a stop. If power is restored during a power failure, the inverter accelerates again. | | |

The above parameter can be set when Pr. 160 "User group read selection" = 0.

Parameter setting

When Pr. 261 is set to "1" or "2", the inverter decelerates to a stop if an undervoltage or power failure occurs.

Operation outline of deceleration to stop at power failure

When undervoltage or power failure has occurred, the output frequency is decreased and controlled so that the converter circuit (DC bus) voltage is constant and decreased to 0Hz to stop.

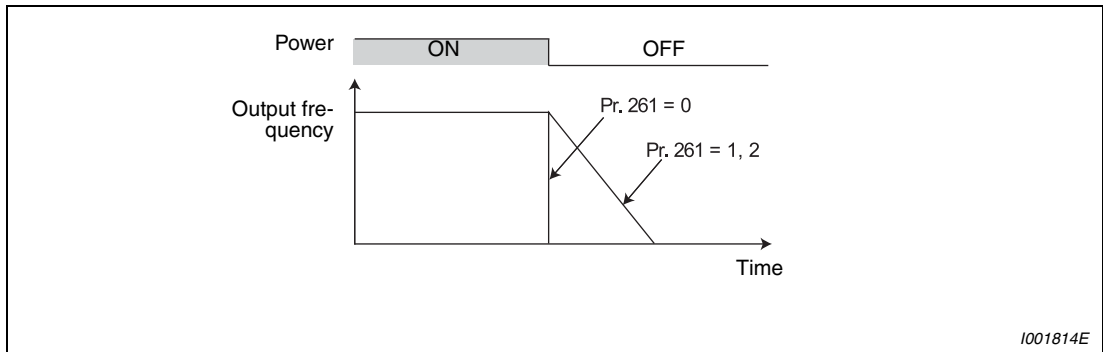

Fig. 6-81: Parameters for stop selection at power failure

Power failure stop mode (Pr. 261 = 1)

If power is restored during power failure deceleration, deceleration to a stop is continued and the inverter remains stopped. To restart, turn off the start signal once, then turn it on again.

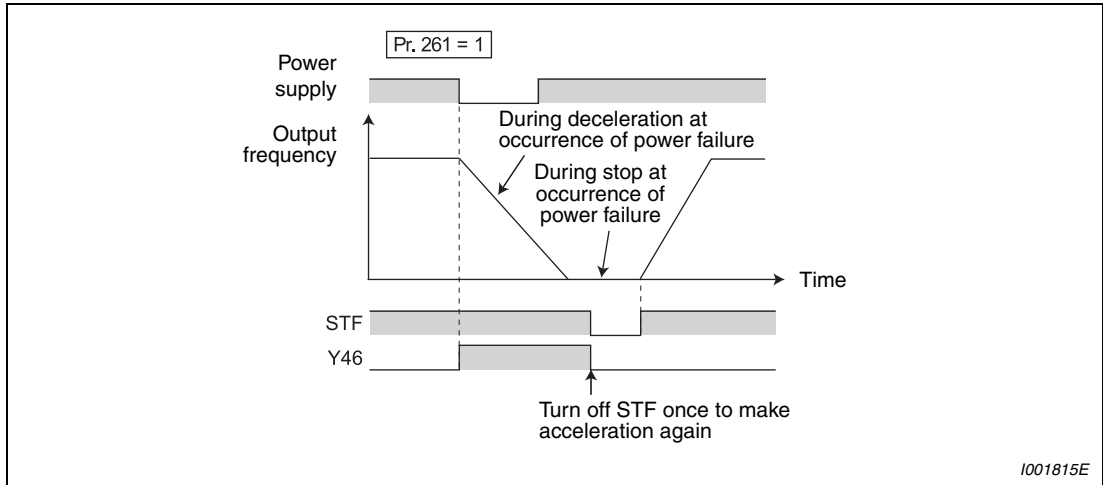

Fig. 6-82: Power restoration

NOTES

When automatic restart after instantaneous power failure is selected (Pr. 57 ≠ 9999), power failure stop function is made invalid and automatic restart operation after instantaneous power failure is made valid.

After a power failure stop, the inverter will not start even if the power is restored with the start signal (STF/STR) input. After switching on the power, turn off the start signal once and then on again to make a start.

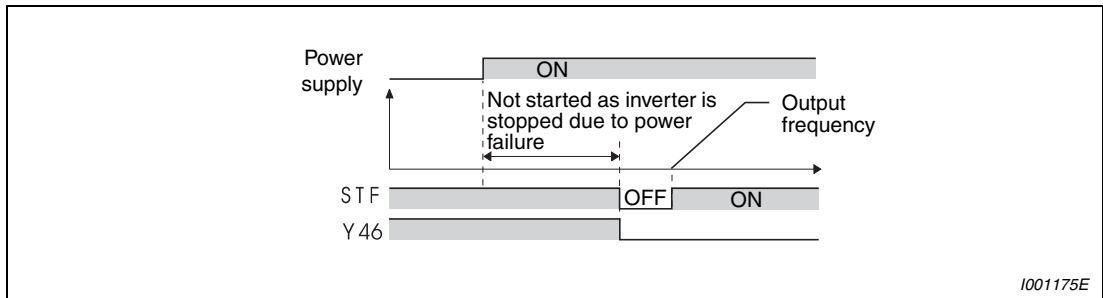

Fig. 6-83: Restart at power restoration

Operation continuation at instantaneous power failure function (Pr. 261 = 2)

When power is restored during deceleration after a power failure, acceleration is made again up to the set frequency.

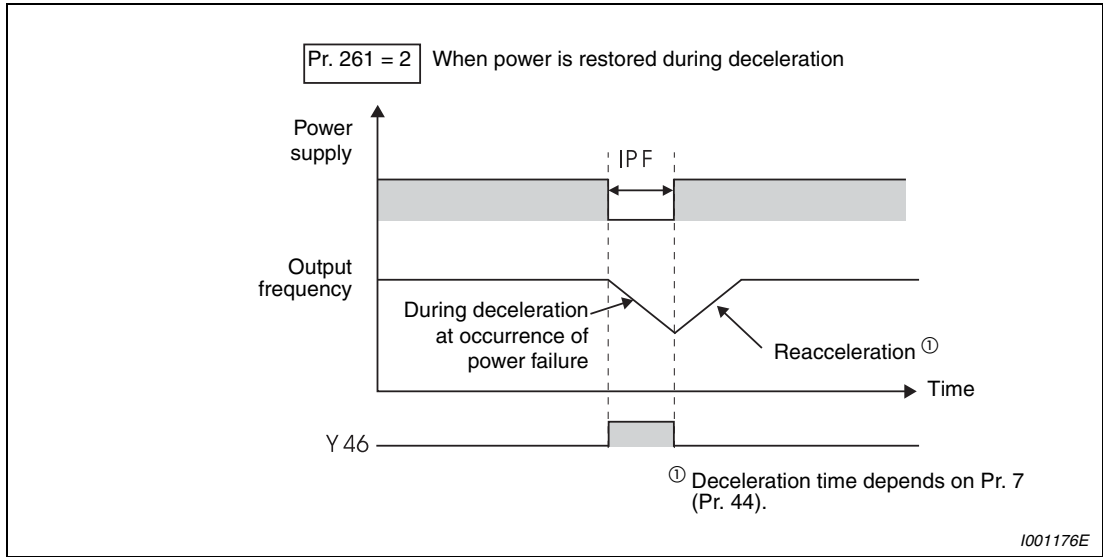

Fig. 6-84: Operation continuation at instantaneous power failure

When this function is used in combination with the automatic restart after instantaneous power failure function (Pr. 57 ≠ 9999), deceleration can be made at a power failure and acceleration can be made again after power restoration.

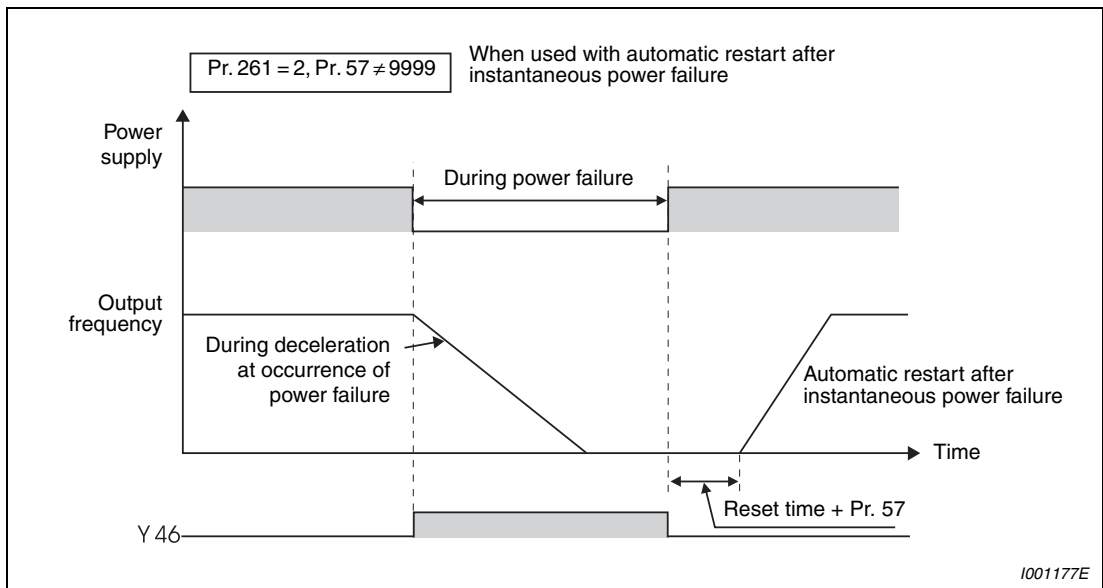

Fig. 6-85: Operation continuation at instantaneous power failure

NOTE

When operation continuation at instantaneous power failure function is used, keep the starting signal (STF/STR) on even during instantaneous power failure. If the starting signal turns off during instantaneous power failure, the inverter decelerates according to the deceleration time setting, causing the motor to coast if enough regenerative energy is not obtained.

Power failure deceleration signal (Y46 signal)

The Y46 signal is on during deceleration at an instantaneous power failure or during a stop after deceleration at an instantaneous power failure.

After a power failure stop, the inverter can not start even if power is restored the start command is given. In this case, check the power failure deceleration signal (Y46 signal) (at occurrence of input phase loss (E.LLF), etc.).

For the Y46 signal, set "46 (forward operation)" or "146 (reverse operation)" to any of Pr. 190 to Pr. 192 "Output terminal function selection" to assign the function.

NOTES

During a stop or trip, the power failure stop selection is not performed.

Changing the terminal assignment using Pr. 190 to Pr. 192 "Output terminal function selection" may affect the other functions. Please make setting after confirming the function of each terminal.

**CAUTION:**

If power-failure deceleration operation is set, some loads may cause the inverter to trip and the motor to coast. The motor will coast if enough regenerative energy is given from the motor.

6.13 Operation setting at alarm occurrence

| Purpose | Parameters that must be set | | Refer to section |
|--|---|-----------------------|------------------|
| Recover by retry operation at alarm occurrence | Retry operation | Pr. 65, Pr. 67–Pr. 69 | 6.13.1 |
| Do not input/output phase failure alarm | Input/output phase failure protection selection | Pr. 251, Pr. 872 | 6.13.2 |

6.13.1 Retry function (Pr. 65, Pr. 67 to Pr. 69)

If a fault occurs, the inverter resets itself automatically to restart. You can also select the fault for a retry.

When you have selected automatic restart after instantaneous power failure (Pr. 57 "Restart coasting time" \neq 9999), restart operation is performed at the retry operation time which is the same of that of a power failure. (Refer to section 6.12.1 for the restart function.)

| Pr. No. | Name | Initial Value | Setting Range | Description | Parameters referred to | Refer to Section |
|-----------|---------------------------------------|---------------|---------------|---|--------------------------|------------------|
| 65 | Retry selection | 0 | 0–5 | An alarm for retry can be selected. | 57 Restart coasting time | 6.12.1 |
| 67 | Number of retries at alarm occurrence | 0 | 0 | No retry function | | |
| | | | 1–10 | Set the number of retries at alarm occurrence. An alarm output is not provided during retry operation. | | |
| | | | 101–110 | Set the number of retries at alarm occurrence. (The setting value of minus 100 is the number of retries.) An alarm output is provided during retry operation. | | |
| 68 | Retry waiting time | 1 s | 0.1–360s | Set the waiting time from when an inverter alarm occurs until a retry is made. | | |
| 69 | Retry count display erase | 0 | 0 | Clear the number of restarts succeeded by retry. | | |

The above parameters can be set when Pr. 160 "User group read selection" = 0.

Retry operation automatically resets a fault and restarts the inverter at the starting frequency when the time set in Pr. 68 elapses after the inverter is tripped.

Retry operation is performed by setting Pr. 67 to any value other than "0". Set the number of retries at fault occurrence in Pr. 67. When retries fail consecutively more than the number of times set in Pr. 67, a retry count excess fault (E.RET) occurs, resulting in inverter trip. (Refer to retry failure example in Fig. 6-87.)

Use Pr. 68 to set the waiting time from when the inverter trips until a retry is made in the range 0 to 360s. (When the setting value is "0s", the actual time is 0.1s.)

Reading the Pr. 69 value provides the cumulative number of successful restart times made by retry. The cumulative count in Pr. 69 is increased by 1 when a retry is regarded as successful after normal operation continues without faults occurring for more than four times longer than the time set in Pr. 68 after a retry start. (When retry is successful, cumulative number of retry failure is cleared.) Writing "0" to Pr. 69 clears the cumulative count.

During a retry, the Y64 signal is on. For the Y64 signal, assign the function by setting "64 (positive operation)" or "164 (negative operation)" to any of Pr. 190 to Pr. 192 "Output terminal function selection".

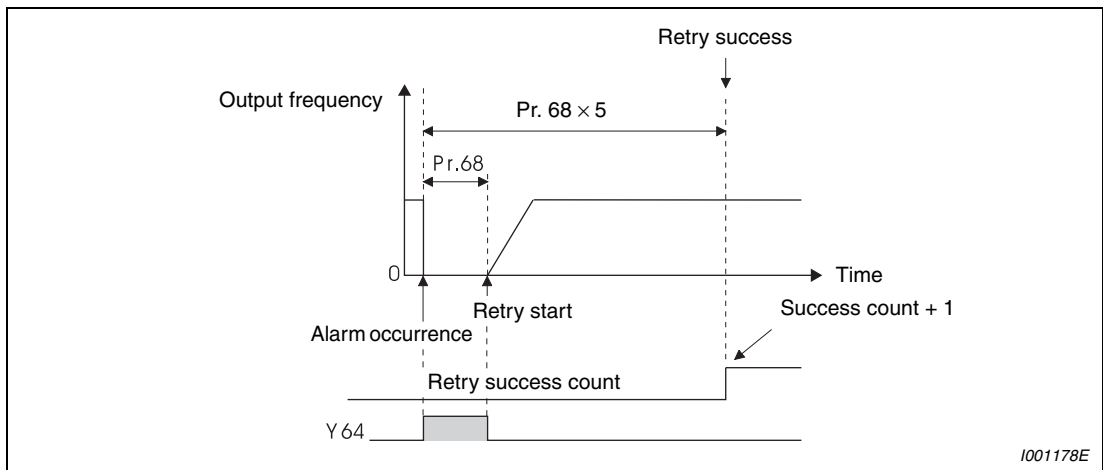

Fig. 6-86: Retry success example

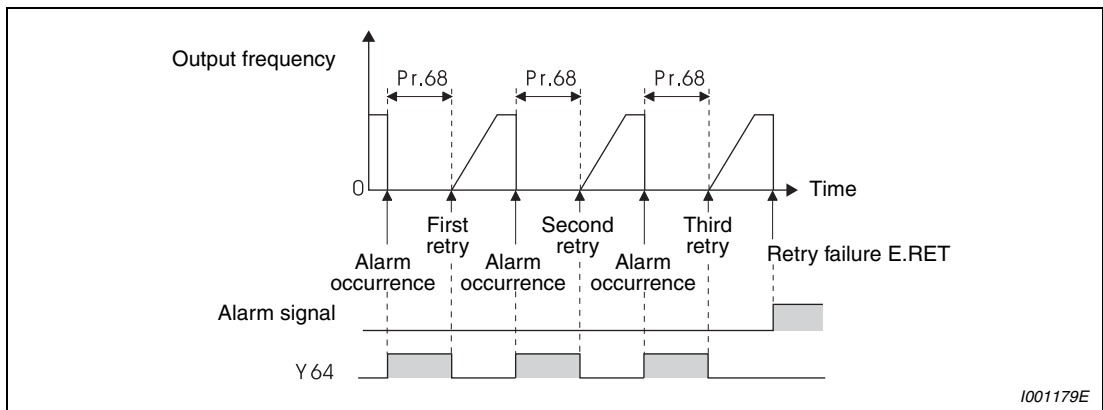

Fig. 6-87: Retry failure example

Using Pr. 65 you can select the alarm that will cause a retry to be executed. No retry will be made for the alarm not indicated.

| Alarm Display for Retry | Name | Parameter 65 Setting | | | | | |
|-------------------------|--|----------------------|---|---|---|---|---|
| | | 0 | 1 | 2 | 3 | 4 | 5 |
| E.OC1 | Over current shut-off during acceleration | ✓ | ✓ | — | ✓ | ✓ | ✓ |
| E.OC2 | Over current shut-off during constant speed | ✓ | ✓ | — | ✓ | ✓ | |
| E.OC3 | Over current shut-off during deceleration or stop | ✓ | ✓ | — | ✓ | ✓ | ✓ |
| E.OV1 | Regenerative over voltage shut-off during acceleration | ✓ | — | ✓ | ✓ | ✓ | — |
| E.OV2 | Regenerative over voltage shut-off during constant speed | ✓ | — | ✓ | ✓ | ✓ | — |
| E.OV3 | Regenerative over voltage shut-off during deceleration or stop | ✓ | — | ✓ | ✓ | ✓ | — |
| E.THM | Motor overload shut-off (electronic thermal relay function) | ✓ | — | — | — | — | — |
| E.THT | Inverter overload shut-off (electronic thermal relay function) | ✓ | — | — | — | — | — |
| E.BE | Brake transistor alarm detection/Internal circuit error | ✓ | — | — | — | ✓ | — |
| E.GF | Output side earth (ground) fault over current protection | ✓ | — | — | — | ✓ | — |
| E.USB | USB communication fault | ✓ | — | — | — | ✓ | — |
| E.OHT | External thermal relay operation | ✓ | — | — | — | — | — |
| E.OLT | Stall Prevention | ✓ | — | — | — | ✓ | — |
| E.OP1 | Communication option fault | ✓ | — | — | — | ✓ | — |
| E.PE | Parameter storage device alarm | ✓ | — | — | — | ✓ | — |
| E.MB4 | Brake sequence fault | ✓ | — | — | — | ✓ | — |
| E.MB5 | | ✓ | — | — | — | ✓ | — |
| E.MB6 | | ✓ | — | — | — | ✓ | — |
| E.MB7 | | ✓ | — | — | — | ✓ | — |
| E.ILF | Input phase failure | ✓ | — | — | — | ✓ | — |

Tab. 6-45: Faults selected for retry

NOTES

When terminal assignment is changed using Pr. 190 to Pr. 192, the other functions may be affected. Make setting after confirming the function of each terminal.

For a retry error, only the description of the first alarm is stored.

When an inverter alarm is reset by the retry function at the retry time, the accumulated data of the electronic thermal relay function, regeneration converter duty etc. are not cleared. (Different from the power-on reset.)

Retry is not performed if E.PE (Parameter storage device fault) occurred at power on.



CAUTION:

When you have selected the retry function, stay away from the motor and machine unless required. They will start suddenly (after the reset time has elapsed) after occurrence of an alarm.

When you have selected the retry function, apply CAUTION seals in easily visible places.

6.13.2 Input/output phase failure protection selection (Pr. 251, Pr. 872)

You can disable the output phase failure function that stops the inverter output if one of the inverter output side (load side) three phases (U, V, W) opens.

Input phase loss protection is a function to stop the inverter output if one of the three phases (R/L1, S/L2, T/L3) on the inverter's input side is lost.

| Pr. No. | Name | Initial Value | Setting Range | Description | Parameters referred to | Refer to Section |
|---------|---|---------------|---------------|---|------------------------|------------------|
| 251 | Output phase failure protection selection | 1 | 0 | Without output phase failure protection | — | |
| | | | 1 | With output phase failure protection | | |
| 872 | Input phase failure protection selection ^① | 0 | 0 | Without input phase failure protection | | |
| | | | 1 | With input phase failure protection | | |

The above parameters can be set when Pr. 160 "User group read selection" = 0.

^① Available only for the three-phase power input specification model.

Output phase failure protection selection (Pr. 251)

If phase loss occurs during inverter running (except for during DC brake operation, or output frequency is 1Hz or less), output phase loss protection (E.LF) activates, and inverter trips.

When Pr. 251 is set to "0", output phase failure protection (E.LF) becomes invalid.

Input phase failure protection selection (Pr. 872)

When Pr. 872 is set to "1", input phase failure protection (E.ILF) is provided if a phase failure of one phase among the three phases is detected for 1s continuously.

NOTES

If an input phase failure continues for a long time during inverter operation, the converter section and capacitor lives of the inverter will be shorter.

As phase loss is detected according to the bus voltage change, it can not be detected if the load is light. Also, if the power supply voltage is imbalanced, phase loss is less likely detected.

Phase loss can not be detected during regeneration load operation.

If parameter copy is performed from single-phase power input specification model to three-phase power input specification model, Pr. 872 setting may be changed. Check Pr. 872 setting after parameter copy.

6.13.3 Earth (ground) fault detection at start (Pr. 249)

You can choose whether to make earth (ground) fault detection at start valid or invalid. Earth (Ground) fault detection is executed only right after the start signal is input to the inverter.

Protective function will not activate if an earth (ground) fault occurs during operation.

| Pr. No. | Name | Initial Value | Setting Range | Description | Parameters referred to | Refer to Section |
|---------|---|---------------|---------------|--|------------------------|------------------|
| 249 | Earth (ground) fault detection at start | 0 | 0 | Without earth (ground) fault detection | — | |
| | | | 1 | With earth (ground) fault detection | | |

The above parameter can be set when Pr. 160 "User group read selection" = 0.

NOTES

As detection is executed at starting, output is delayed for approx. 20ms every starting.

If an earth (ground) fault is detected with "1" set in Pr. 249, output side earth (ground) fault overcurrent (E.GF) is detected and the inverter trips. (Refer to page 7-12.)

If the motor capacity is smaller than the inverter capacity for the FR-E740-120 or more, earth (ground) fault detection may not be provided.

6.14 Energy saving operation

| Purpose | Parameters that must be set | | Refer to Section |
|-------------------------|--|--------|------------------|
| Energy saving operation | Energy saving operation and optimum excitation control | Pr. 60 | 6.14.1 |

6.14.1 Optimum excitation control (Pr. 60)

Without a fine parameter setting, the inverter automatically performs energy saving operation. This inverter is optimum for fan and pump applications.

| Pr. No. | Name | Initial Value | Setting Range | Description | Parameters referred to | Refer to Section |
|---------|--|---------------|---------------|---------------------------------|---|------------------|
| 60 | Energy saving control selection ^① | 0 | 0 | Normal operation mode | Advanced magnetic flux vector control General-purpose magnetic flux vector control | 6.3.2 6.3.3 |
| | | | 9 | Optimum excitation control mode | | |

The above parameters can be set when Pr. 160 "User group read selection" = 0.

^① When parameter is read using the FR-PU04, a parameter name different from an actual parameter is displayed.

Optimum excitation control mode (OEC) (Pr. 60 = 9)

When "9" is set in Pr. 60, the inverter operates in the optimum excitation control mode.

The optimum excitation control mode is a control system which controls excitation current to improve the motor efficiency to maximum and determines output voltage as an energy saving method.

NOTES

When the motor capacity is too small as compared to the inverter capacity or two or more motors are connected to the inverter, the energy saving effect is not expected.

When the optimum excitation control mode is selected, deceleration time may be longer than the setting value. Since overvoltage alarm tends to occur as compared to the constant torque load characteristics, set a longer deceleration time.

Optimum excitation control functions only under V/f control. Optimum excitation control does not function under advanced magnetic flux vector control and general-purpose magnetic flux vector control.

Optimum excitation control will not be performed during an automatic restart after instantaneous power failure.

Since output voltage is controlled by optimum excitation control, output current may slightly increase.

6.15 Motor noise, EMI measures, mechanical resonance

| Purpose | Parameters that must be set | | Refer to Section |
|---|--|-----------------|------------------|
| Reduction of the motor noise Measures against EMI and leakage currents | Carrier frequency and Soft-PWM selection | Pr. 72, Pr. 240 | 6.15.1 |
| Reduce mechanical resonance | Speed smoothing control | Pr. 653 | 6.15.2 |

6.15.1 PWM carrier frequency and soft-PWM control (Pr. 72, Pr. 240)

You can change the motor sound.

| Pr. No. | Name | Initial Value | Setting Range | Description | Parameters referred to | Refer to Section |
|---------|--------------------------------|---------------|--------------------------|---|--|------------------|
| 72 | PWM frequency selection ① | 1 | 0–15 (integral value) | PWM carrier frequency can be changed. The setting displayed is in [kHz]. The settings indicate the following frequencies: 0 0.7kHz Settings between 1–14 correspond directly to the frequency values. 15 14.5kHz | 156 Stall prevention operation selection | 6.3.5 |
| | | | | Soft-PWM is invalid | | |
| 240 | Soft-PWM operation selection ① | 1 | 0 | Soft-PWM is invalid | | |
| | | | 1 | When Pr. 72 = 0 to 5, Soft-PWM is valid. | | |

The above parameters can be set when Pr. 160 "User group read selection" = 0.

① The above parameters allow its setting to be changed during operation in any operation mode even if "0" (initial value) is set in Pr. 77 "Parameter write selection".

PWM carrier frequency changing (Pr. 72)

You can change the PWM carrier frequency of the inverter.

Changing the PWM carrier frequency produces an effect on avoiding the resonance frequency of a mechanical system or motor or on reducing noise or leakage current generated from the inverter.

Soft-PWM control (Pr. 240)

Soft-PWM control is a control system that changes the motor noise from a metallic tone into an unoffending complex tone.

NOTES

Decreasing the PWM carrier frequency reduces inverter-generated noise and leakage current, but increases motor noise.

When PWM carrier frequency is set to 1kHz or less (Pr. 72 ≤ 1), fast response current limit may function prior to stall prevention operation due to increase in ripple currents, resulting in insufficient torque. In such case, set fast-response current limit operation invalid using Pr. 156 "Stall prevention operation selection".

When setting 2kHz or more in Pr. 72 to perform operation in the place where the ambient temperature exceeding 40°C, caution should be taken as the rated inverter current should be reduced. (Refer to appendix A-1.)

6.15.2 Speed smoothing control (Pr. 653)

Vibration due to mechanical resonance influences the inverter control, causing the output current (torque) unstable. In this case, the output current (torque) fluctuation can be reduced to ease vibration by changing the output frequency.

| Pr. No. | Name | Initial Value | Setting Range | Description | Parameters referred to | Refer to Section |
|------------|-------------------------|---------------|---------------|--|------------------------|------------------|
| 653 | Speed smoothing control | 0 | 0-200% | Increase or decrease the value using 100% as reference to check an effect. | — | |

The above parameter can be set when Pr. 160 "User group read selection" = 0.

Control block diagram

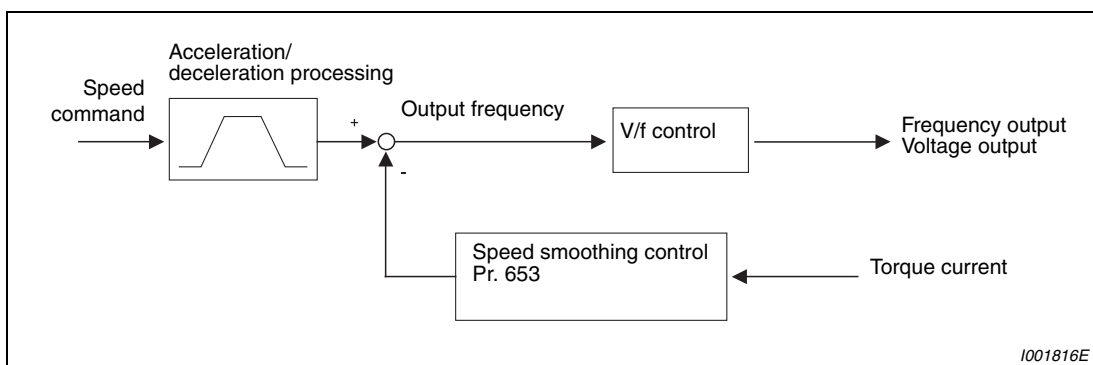

Fig. 6-88: Control block diagram of the speed smoothing control

Setting method

If vibration due to mechanical resonance occurs, set 100% in Pr. 653, run the inverter at the frequency which generates maximum vibration and check if the vibration will be reduced or not after several seconds.

If effect is not produced, gradually increase the Pr. 653 setting and check the effect repeatedly until the most effective value is set in Pr. 653.

If vibration becomes large by increasing the Pr. 653 setting, gradually decrease the Pr. 653 setting than 100% to check the effect in a similar manner.

NOTE

Depending on the machine, vibration may not be reduced enough or an effect may not be produced.

6.16 Frequency setting by analog input (terminal 2, 4)

| Purpose | Parameters that must be set | | Refer to Section |
|---|--|--|------------------|
| Selection of voltage/current input (terminal 2, 4) Perform forward/reverse rotation by analog input. | Analog input selection | Pr. 73, Pr. 267 | 6.16.1 |
| Adjustment (calibration) of analog input frequency and voltage (current) | Bias and gain of frequency setting voltage (current) | Pr. 125, Pr. 126, Pr. 241, C2–C7 (Pr. 902–Pr. 905) | 6.16.3 |

6.16.1 Analog input selection (Pr. 73, Pr. 267)

You can select the function that switches between forward rotation and reverse rotation according to the analog input terminal specifications and input signal.

The following settings are possible:

- Select reference voltages and currents: 0–10V, 0–5V or 0/4–20mA
- Suppress motor reversing

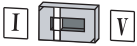
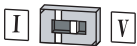
| Pr. No. | Name | Initial Value | Setting Range | Description | | Parameters referred to | Refer to Section |
|------------|----------------------------|---------------|-------------------------------------|---|------------------------------|--|--------------------------------------|
| 73 | Analog input selection | 1 | 0 | Terminal 2: 0–10V | Without reversible operation | 125 Terminal 2 frequency setting gain frequency 126 Terminal 4 frequency setting gain frequency C2 Terminal 2 frequency setting bias frequency to – C7 Terminal 4 frequency setting gain | 6.16.3 6.16.3 6.16.3 6.16.3 |
| | | | 1 | Terminal 2: 0–5V | | | |
| | | | 10 | Terminal 2: 0–10V | With reversible operation | | |
| | | | 11 | Terminal 2: 0–5V | | | |
| 267 | Terminal 4 input selection | 0 | Voltage/current input switch | | Description | | |
| | | | 0 |  | Terminal 4: 0/4–20mA | | |
| | | | 1 | | Terminal 4: 0–5V | | |
| | | | 2 |  | Terminal 4: 0–10V | | |

The above parameters can be set when Pr. 160 "User group read selection" = 0.

Selection of analog input specifications

For the terminal 2 for analog voltage input, 0 to 5V (initial value) or 0 to 10V can be selected. Either voltage input (0 to 5V, 0 to 10V) or current input (4 to 20mA initial value) can be selected for terminal 4 used for analog input. Change the input specifications by setting Pr. 73 and Pr. 267 and voltage/current input switch.

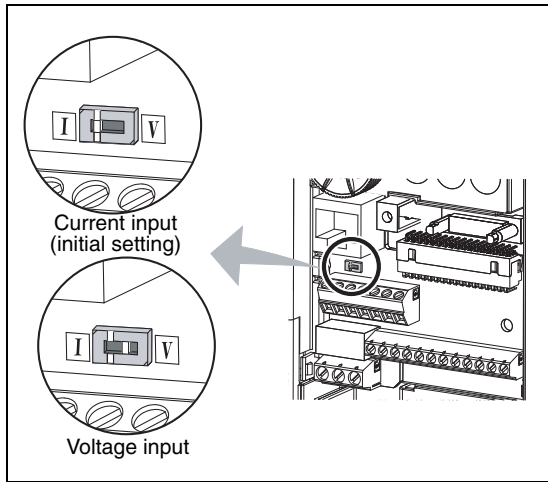

Fig. 6-89:
Voltage/current input switch

I001934E

Rated specifications of terminal 4 change according to the voltage/current input switch setting:
 Voltage input: Input resistance $10k\Omega \pm 1k\Omega$, maximum permissible input voltage 20V DC
 Current input: Input resistance $233\Omega \pm 5\Omega$, maximum permissible current 30mA



CAUTION:

Set Pr. 267 and a voltage/current input switch correctly, then input an analog signal in accordance with the setting. Incorrect setting as in the table below could cause component damage. Incorrect settings other than below can cause abnormal operation.

| Setting Causing Component Damage | | Operation |
|----------------------------------|----------------|--|
| Switch setting | Terminal input | |
| I (current input) | Voltage input | This could cause component damage to the analog signal output circuit of signal output devices. (electrical load in the analog signal output circuit of signal output devices increases) |
| V (voltage input) | Current input | This could cause component damage of the inverter signal input circuit. (output power in the analog signal output circuit of signal output devices increases) |

Refer to the following table and set Pr. 73 and Pr. 267. The half-tone screened areas indicate the main speed setting.

| Pr. 73 | Terminal 2 | Terminal 4 | | Polarity Reversible |
|----------------------|------------|------------|---|---------------------|
| | | AU signal | | |
| 0 | 0-10V | OFF | — | No |
| 1 (initial value) | 0-5V | | | |
| 10 | 0-10V | | | Yes |
| 11 | 0-5V | | | |
| 0 | — | ON | According to Pr. 267: 0: 4-20mA (initial value) 1: 0-5V 2: 0-10V | No |
| 1 (initial value) | | | | |
| 10 | | | | Yes |
| 11 | | | | |

Tab. 6-46: Setting of parameter 73 and 267

The terminal used for the AU signal input, set "4" in Pr. 178 to Pr. 184 "Input terminal function selection" to assign functions.

NOTES

- Turn the AU signal on to make terminal 4 valid.
- Make sure that the parameter and switch settings are the same. Different setting may cause a fault, failure or malfunction.
- Use Pr. 125 (Pr. 126) "Frequency setting gain" to change the maximum output frequency at input of the maximum output frequency command voltage (current). At this time, the command voltage (current) need not be input. Also, the acceleration/deceleration time, which is a slope up/down to the acceleration/deceleration reference frequency, is not affected by the change in Pr. 73 setting.
- Changing the terminal assignment using Pr. 178 to Pr. 184 "Input terminal function selection" may affect the other functions. Make setting after confirming the function of each terminal.

Perform operation by analog input voltage

The frequency setting signal inputs 0 to 5V DC (or 0 to 10V DC) to across the terminals 2-5. The 5V (10V) input is the maximum output frequency.

The power supply 5V can be input by either using the internal power supply or preparing an external power supply. Prepare an external power supply to input the power supply 10V. For the built-in power supply, terminals 10-5 provide 5V DC output.

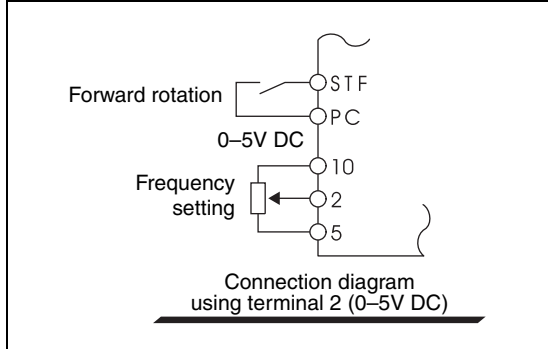

Fig. 6-90:
Frequency setting by voltage 0-5V DC

1001182E

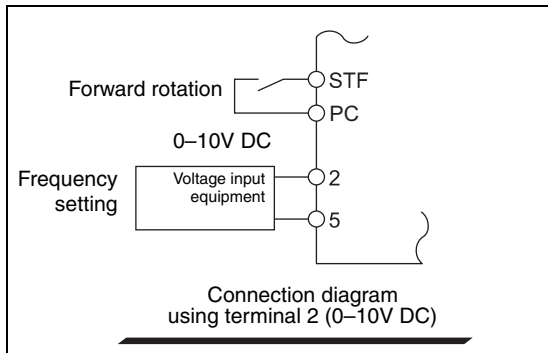

Fig. 6-91:
Frequency setting by voltage 0-10V DC

1001884E

| Terminal | Inverter Built-in Power Supply Voltage | Frequency Setting Resolution | Pr. 73 (terminal 2 input voltage) |
|----------|--|------------------------------|-----------------------------------|
| 10 | 5V DC | 0.1Hz/50Hz | 0-5V DC |

Tab. 6-47: Built-in power supply voltage

When inputting 10V DC to the terminal 2, set "0" or "10" in Pr. 73. (The initial value is 0 to 5V.)

Setting "1 (0 to 5V DC)" or "2 (0 to 10V DC)" in Pr. 267 and a voltage/current input switch in the OFF position changes the terminal 4 to the voltage input specification. When the AU signal turns on, the terminal 4 input becomes valid.

NOTE

The wiring length of the terminal 10, 2, 5 should be 30m maximum.

Perform operation by analog input current

When the pressure or temperature is controlled constant by a fan, pump, etc., automatic operation can be performed by inputting the output signal 0/4 to 20mA of the adjuster to across the terminals 4-5.

NOTE

The AU signal must be turned on to use the terminal 4. For the terminal used for AU signal input, set "4" in any of Pr. 178 to Pr. 184 to assign the function.

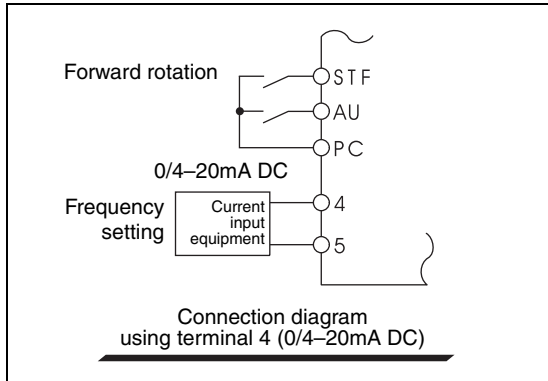

Fig. 6-92:

Frequency setting by the function "Current input 0/4-20mA" assigned to terminal 4

1001184E

Perform forward/reverse rotation by analog input (polarity reversible operation)

Setting "10" or "11" in Pr. 73 and adjusting Pr. 125 (Pr. 126) "Terminal 2 frequency setting gain frequency" (Terminal 4 frequency setting gain frequency) and C2 (Pr. 902) "Terminal 2 frequency setting bias frequency" to C7 (Pr.905) "Terminal 4 frequency setting gain" makes reverse operation by terminal 2 (terminal 4) valid.

Example ▽

When performing reversible operation by terminal 2 (0 to 5V) input.

- ① Set "11" in Pr. 73 to make reversible operation valid.
Set frequency at maximum analog input in Pr. 125 (Pr. 903).
- ② Set 1/2 of the value set in C4 (Pr. 903) in C3 (Pr. 902).
- ③ Reversible operation is performed when 0 to 2.5V DC is input and forward rotation when 2.5 to 5V DC.

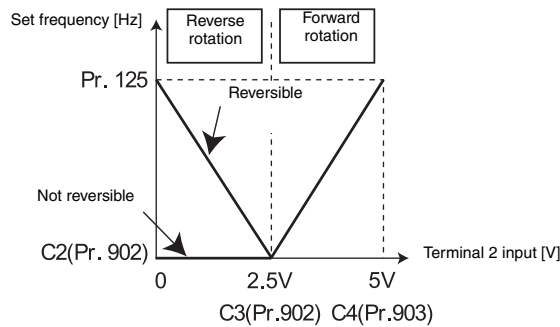

CAUTION:

When reversible operation is set, be aware of reverse rotation operation when analog input stops (only the start signal is input).

NOTE

When reversible operation is valid, reversible operation (0 to 4mA: reverse operation, 4mA to 20mA: forward operation) is performed by terminal 4 in the initial setting.

6.16.2 Input filter time constant (Pr. 74)

If the set point signal (terminal 2 or 4) is an unstable signal or contains noise you can filter out the instability or noise by increasing the setting value of Pr. 74.

| Pr. No. | Name | Initial Value | Setting Value | Description | Parameters referred to | Refer to Section |
|-----------|----------------------------|---------------|---------------|--|------------------------|------------------|
| 74 | Input filter time constant | 1 | 0-8 | Set the primary delay filter time constant for the analog input. A larger setting results in a larger filter. | — | |

The above parameters can be set when Pr. 160 "User group read selection" = 0.

Increase the filter time constant if steady operation cannot be performed due to noise. A larger setting results in slower response. (The time constant can be set between approximately 1ms to 1s with the setting of 0 to 8.)

6.16.3 Bias and gain of frequency setting voltage (current) [Pr. 125, Pr. 126, Pr. 241, C2 (Pr. 902) to C7 (Pr. 905)]

You can set the magnitude (slope) of the output frequency as desired in relation to the frequency setting signal (0 to 5V, 0 to 10V or 0/4 to 20mA DC).

These parameters can be used to configure the inverter precisely for set point signals that either exceed or do not quite reach 5V or 10V or 20mA. These settings can also be used to configure inverse control (i.e. high output frequency at minimum set point signal, minimum output frequency at maximum set point signal).

| Pr. No. | Name | Initial Value | Setting Range | Description |
|-----------------|--|---------------|---------------|---|
| 125 | Terminal 2 frequency setting gain frequency | 50Hz | 0–400Hz | Set the frequency of terminal 2 input gain (maximum). |
| 126 | Terminal 4 frequency setting gain frequency | 50Hz | 0–400Hz | Set the frequency of terminal 4 input gain (maximum). |
| 241 | Analog input display unit switchover ^{① ③} | 0 | 0 | Displayed in % |
| | | | 1 | Displayed in V/mA |
| C2 (902) | Terminal 2 frequency setting bias frequency ^{① ②} | 0Hz | 0–400Hz | Set the frequency on the bias side of terminal 2 input. |
| C3 (902) | Terminal 2 frequency setting bias ^{① ②} | 0% | 0–300% | Set the converted % of the bias side voltage (current) of terminal 2 input. |
| C4 (903) | Terminal 2 frequency setting gain ^{① ②} | 100% | 0–300% | Set the converted % of the gain side voltage of terminal 2 input.) |
| C5 (904) | Terminal 4 frequency setting bias frequency ^{① ②} | 0Hz | 0–400Hz | Set the frequency on the bias side of terminal 4 input. |
| C6 (904) | Terminal 4 frequency setting bias ^{① ②} | 20% | 0–300% | Set the converted % of the bias side current (voltage) of terminal 4 input. |
| C7 (905) | Terminal 4 frequency setting gain ^{① ②} | 100% | 0–300% | Set the converted % of the gain side current (voltage) of terminal 4 input. |

| Parameters referred to | Refer to Section |
|---|------------------|
| 20 Acceleration/ deceleration reference frequency | 6.7.1 |
| 73 Analog input selection | 6.16.1 |
| 267 Terminal 4 input selection | 6.16.1 |
| 79 Operation mode selection | 6.18.1 |

① The above parameters can be set when Pr. 160 "User group read selection" = 0.

② The parameter number in parentheses is the one for use with the operation panel (PA02) for the FR-E500 series or parameter unit (FR-PU04/FR-PU07).

③ The above parameter allow its setting to be changed during operation in any operation mode even if "0" (initial value) is set in Pr. 77 "Parameter write selection".

Change the frequency at maximum analog input (Pr. 125, Pr. 126)

Set a value to Pr. 125 (Pr. 126) when changing only the frequency setting (gain) of the maximum analog input power (current). (C2 (Pr. 902) to C7 (Pr. 905) setting need not be changed.)

Analog input bias/gain calibration [C2 (Pr. 902) to C7 (Pr. 905)]

The parameters for input bias and gain can be used to configure the inverter for set point signals that do not exactly match 5V or 10V or 20mA. You can enter the exact output frequencies to be associated with the minimum and maximum signal values separately for terminals 2 and 4. This feature can also be used to configure an inverse control characteristic (i.e. high output frequency at minimum set point signal, minimum output frequency at maximum set point signal).

Set the bias frequency of the terminal 2 input using C2 (Pr. 902). (Factory-set to the frequency at 0V.)

Parameter C3 (Pr. 902) is the frequency setting bias for the input signal at terminal 2, i.e. the minimum value of the analog signal. When signals are smaller than this value the frequency set point signal will be limited to the value set with C2.

Parameter 125 sets the gain for the terminal 2 output frequency. This is the frequency set point value that corresponds to the maximum analog signal defined with Pr. 73. (Pr. 125 is set to a default value of 50Hz at the factory.)

Parameter C4 (Pr. 903) sets the gain for the input signal on terminal 2, i.e. the maximum value of the analog signal connected to terminal 2. When signals exceed this value the frequency set point value is limited to the value stored in Pr. 125.

Parameter C5 (Pr. 904) sets the frequency set point bias frequency for terminal 4. This is the frequency corresponding to the minimum analog signal. (This parameter is set to a default value of 0Hz at the factory.)

Parameter C6 (Pr. 904) sets the bias of the input signal on terminal 4, i.e. the minimum value of the analog signal connected to terminal 4. When the signal on this terminal is lower than this value the frequency set point value is limited to the value set with C5. (This parameter is set to a default value of 20% at the factory, which corresponds to approx. 4mA.)

Parameter 126 sets the gain for the terminal 4 output frequency. This is the frequency set point value that corresponds to the maximum analog signal defined with Pr. 73. (Pr. 126 is set to a default value of 50Hz at the factory.)

Parameter C7 (Pr. 905) sets the gain of the input signal on terminal 4, i.e. the maximum value of the analog signal connected to terminal 4. When the signal on this terminal is higher than this value the frequency set point value is limited to the value set with Pr. 126.

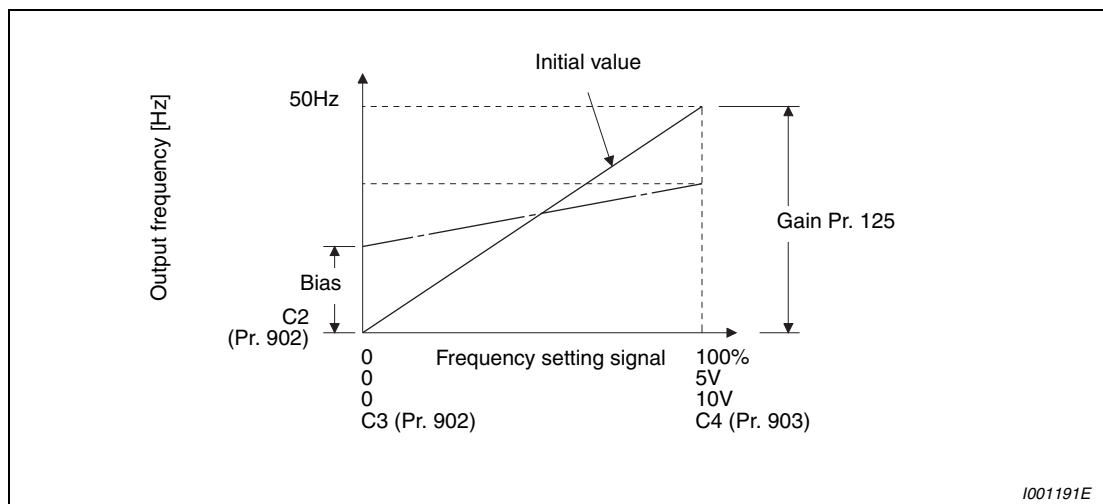

Fig. 6-93: Signal adjustment of terminal 2

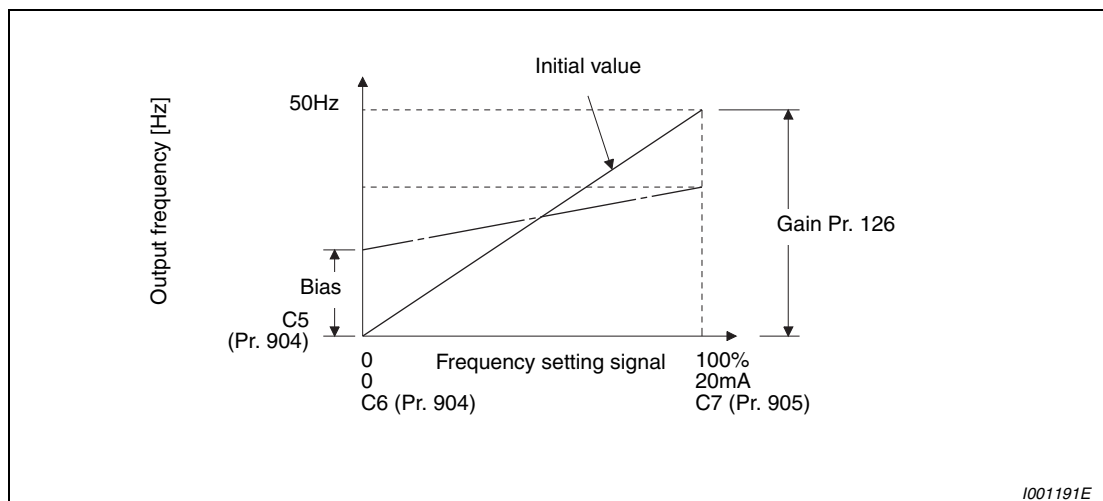

Fig. 6-94: Signal adjustment of terminal 4

There are three methods to adjust the frequency setting voltage (current) bias/gain:

- Method to adjust any point by application of voltage (current) to across the terminals 2-5 (4-5). (Refer to page 6-184.)
- Method to adjust any point without application of a voltage (current) to across terminals 2-5 (4-5). (Refer to page 6-185.)
- Adjusting only the frequency without adjusting the voltage (current). (Refer to page 6-186.)

NOTE

When voltage/current input signal for terminal 4 was switched using Pr. 267 and voltage/current input switch, perform calibration without fail.

Analog input display unit changing (Pr. 241)

The level display for the analog signal connected to terminal 2 or terminal 4 can be switched between a % display and a display in V or mA.

Depending on the terminal input specification set to Pr. 73 and Pr. 267, the display units of C3 (Pr. 902), C4 (Pr. 903), C6 (Pr. 904) and C7 (Pr. 905) change as shown below.

| Analog Command (terminal 2, 4) (depending on Pr. 73, Pr. 267, and voltage/current input switch) | Pr. 241 = 0 (initial value) | Pr. 241 = 1 |
|---|-------------------------------------|-------------------------------------|
| 0–5V | 0 to 5V → 0 to 100% is displayed. | 0 to 5V → 0 to 5V is displayed. |
| 0–10V | 0 to 10V → 0 to 100% is displayed. | 0 to 10V → 0 to 10V is displayed. |
| 0/4–20mA | 0 to 20mA → 0 to 100% is displayed. | 0 to 20mA → 0 to 20mA is displayed. |

Tab. 6-48: Units when displaying the set value

Note that the LED A also light up as an additional indicator when Pr. 241 is set to "1" and the display is set to the settings for C3/C4 or C6/C7.

Frequency setting signal (current) bias/gain adjustment method

- Method to adjust any point by application of voltage (current) to across the terminals 2-5 (4-5). The following example illustrating the procedure assumes that Pr. 241 is set to "0":

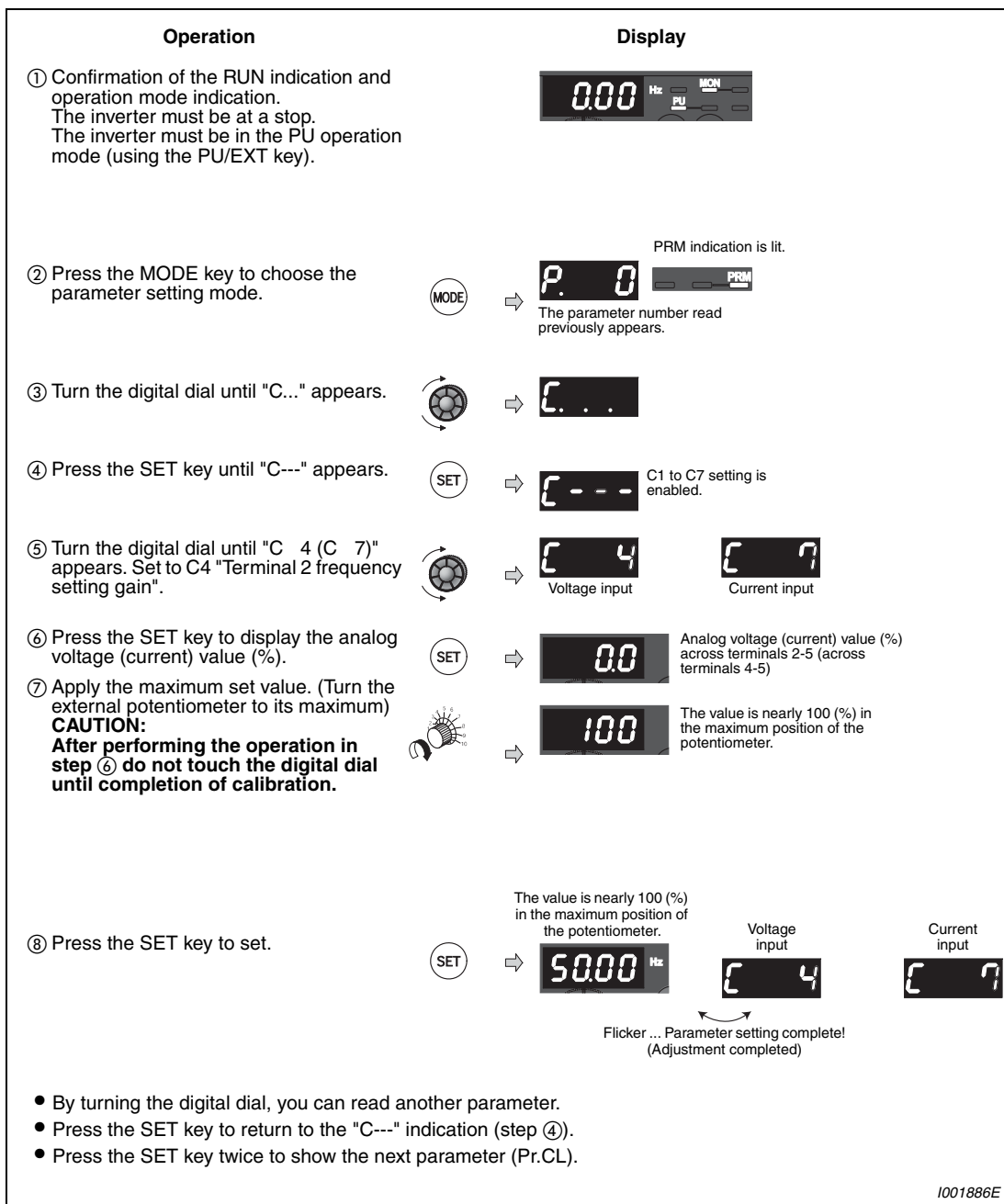

Fig. 6-95: Bias and gain adjustment by application of an reference signal

NOTES

- If the frequency meter (display meter) connected across the terminals AM-5 does not indicate just 50Hz, set the calibration parameter C1 "AM terminal calibration". (Refer to section 6.11.4).
- Error code Er3 may be displayed when you save if the frequency values for gain and bias are less than approx. 5% apart. If this happens correct the frequency settings and save again.

2. Method to adjust any point without application of a voltage (current) to across terminals 2-5 (4-5).
 (This example shows how to change from 4V to 5V, assuming that Pr. 241 is set to "1".)

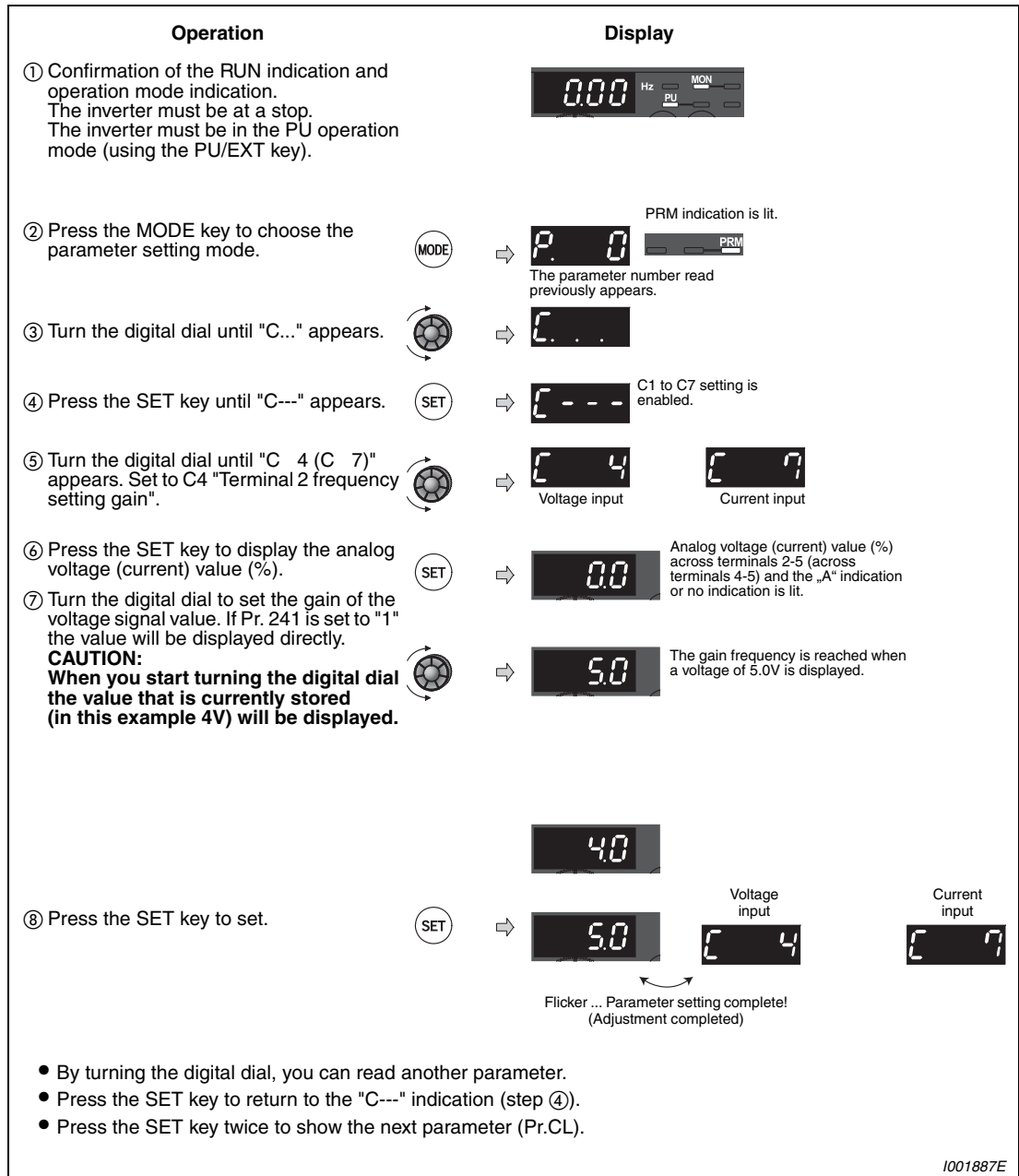

Fig. 6-96: Bias and gain adjustment without application of an reference signal

NOTE

By pressing the digital dial after step ⑥, you can confirm the current frequency setting bias/gain setting. It cannot be confirmed after execution of step ⑦.

3. Method to adjust only the frequency without adjustment of a gain voltage (current).
 (The gain frequency is changed from 50 Hz to 40 Hz.)

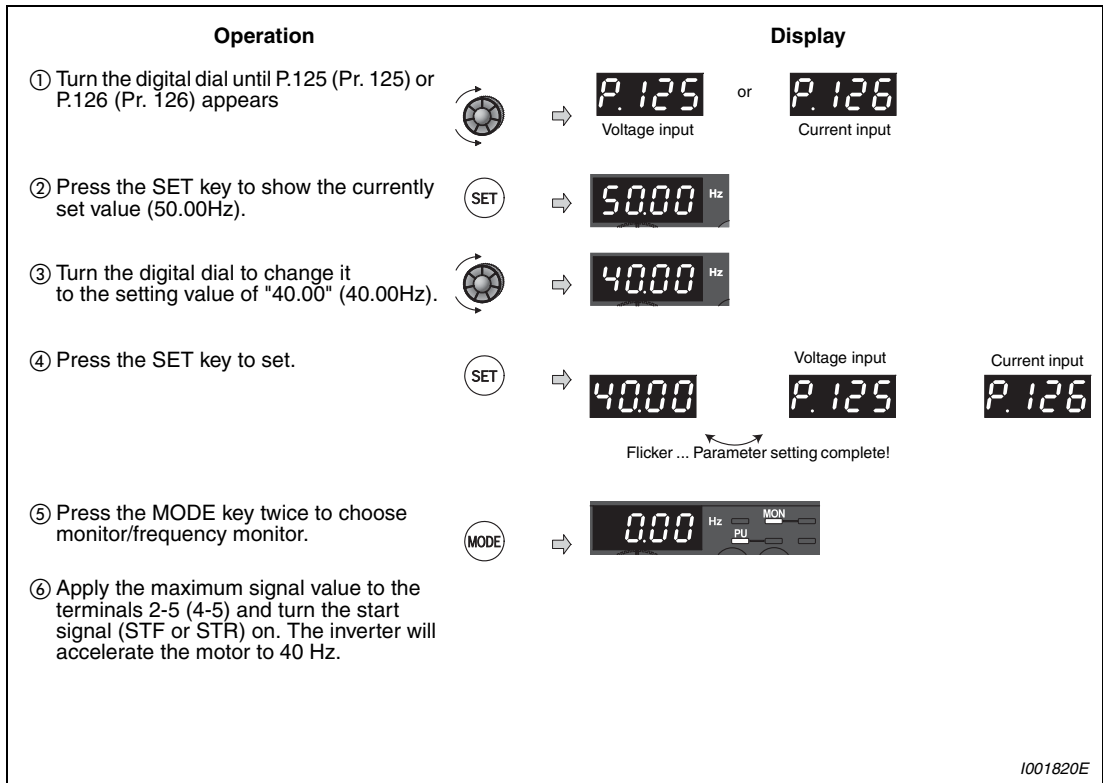

Fig. 6-97: Adjusting only the frequency without adjustment of a voltage (current)

NOTES

Changing C4 (Pr. 903) or C7 (Pr. 905) (gain adjustment) value will not change the Pr. 20 value.

For the operation procedure using the parameter unit (FR-PU04/FR-PU07), refer to the FR-PU04/FR-PU07 instruction manual.

When setting the value to 120Hz or more, it is necessary to set Pr. 18 "High speed maximum frequency" to 120Hz or more. (Refer to page 6-50.)

Make the bias frequency setting using calibration parameter C2 (Pr. 902) or C5 (Pr. 904). (Refer to page 6-181.)



CAUTION:

Take care when setting any value other than "0" as the bias speed at 0V (0/4mA). Even if a frequency command is not given, merely turning on the start signal will start the motor at the preset frequency.

6.17 Misoperation prevention and parameter setting restriction

| Purpose | Parameters that must be set | | Refer to Section |
|---|---|-----------------------------|------------------|
| Limit reset function Make alarm stop when PU is disconnected Stop from PU | Reset selection/ disconnected PU detection/ PU stop selection | Pr. 75 | 6.17.1 |
| Prevention of parameter rewrite | Parameter write selection | Pr. 77 | 6.17.2 |
| Prevention of reverse rotation of the motor | Reverse rotation prevention selection | Pr. 78 | 6.17.3 |
| Displays necessary parameters | Display of applied parameters and user group function | Pr. 160, Pr. 172–Pr. 174 | 6.17.4 |
| Control of parameter write by communication | E ² PROM write selection | Pr. 342 | 6.19.3 |

6.17.1 Reset selection/disconnected PU detection/PU stop selection (Pr. 75)

You can select the reset input acceptance, disconnected PU (FR-PU04/FR-PU07) connector detection function and PU stop function.

| Pr. No. | Name | Initial Value | Setting Range | Description | Parameters referred to | Refer to Section |
|-----------|---|---------------|---------------|--|--|------------------|
| 75 | Reset selection/ disconnected PU detection/ PU stop selection | 14 | 0–3/ 14–17 | For the initial value, reset always enabled, without disconnected PU detection, and with PU stop function are set. | 250 Stop selection 551 PU mode operation command source selection | 6.9.3 6.18.3 |

The above parameter can be set when Pr. 160 "User group read selection" = 0.

The Pr. 75 value can be set any time. Also, if parameter (all) clear is executed, this setting will not return to the initial value.

| Pr. 75 | Reset Selection | Disconnected PU Detection | PU Stop Selection |
|-----------------------|--|---|---|
| 0 | Reset input always enabled. | If the PU is disconnected, operation will be continued. | Pressing the STOP key decelerates the motor to a stop only in the PU operation mode. |
| 1 | Enabled only when the protective function is activated | | |
| 2 | Reset input always enabled. | When the PU is disconnected, the inverter output is shut off. | |
| 3 | Enabled only when the protective function is activated | | |
| 14 (initial value) | Reset input always enabled. | If the PU is disconnected, operation will be continued. | Pressing the STOP key decelerates the motor to a stop in any of the PU, external and communication operation modes. |
| 15 | Enabled only when the protective function is activated | | |
| 16 | Reset input always enabled. | When the PU is disconnected, the inverter output is shut off. | |
| 17 | Enabled only when the protective function is activated | | |

Tab. 6-49: Setting of parameter 75

Reset selection

You can select the enable condition of reset function (RES signal, reset command through communication) input.

When Pr. 75 is set to any of "1, 3, 15, 17", a reset can be input only when the inverter is tripped.

NOTES

When the reset signal (RES) is input during operation, the motor coasts since the inverter being reset shuts off the output. Also, the cumulative value of the electronic thermal relay function and the regenerative brake duty are cleared.

The reset key of the PU is valid only when the protective function is activated, independently of the Pr. 75 setting.

Disconnected PU detection

This function detects that the PU (FR-PU04/FR-PU07) has been disconnected from the inverter for longer than 1s and causes the inverter to provide an alarm output (E.PUE) and come to an alarm stop.

When Pr. 75 is set to any of "0, 1, 14, 15", operation is continued if the PU is disconnected.

NOTES

When the PU has been disconnected since before power-on, it is not judged as an alarm.

To make a restart, confirm that the PU is connected and then reset the inverter.

The motor decelerates to a stop when the PU is disconnected during PU jog operation with Pr. 75 set to any of "0, 1, 14, 15" (operation is continued if the PU is disconnected).

When RS-485 communication operation is performed through the PU connector, the reset selection/PU stop selection function is valid but the disconnected PU detection function is invalid.

PU stop selection

In any of the PU operation, external operation and network operation modes, the motor can be stopped by pressing the STOP key of the PU.

When the inverter is stopped by the PU stop function (refer to section 4.3 "Operation panel") in the external operation mode, "PS" is displayed but an alarm is not output. An alarm output is not provided.

After the motor is stopped from the PU, it is necessary to perform PU stop (PS) reset to restart. PS reset can be made from the unit from which PU stop is made (operation panel, parameter unit (FR-PU04/PU07, operation panel for FR-E500 (PA02))).

The motor can be restarted by making PS cancel using a power supply reset or RES signal.

When Pr. 75 is set to any of "0 to 3", PU stop (PS display) is invalid, deceleration to a stop by the STOP key is valid only in the PU operation mode.

NOTE

During operation in the PU operation mode through USB communication or RS-485 communication from the PU connector, the motor decelerates to stop (PU stop) when STOP is entered from the operation panel.

Restarting method when stop was made by pressing the STOP key from the PU during external operation ("PS" is displayed)

Operation panel

- ① After the motor has decelerated to a stop, turn off the STF or STR signal.
- ② Press the PU/EXT key to change to the PU operation mode. The PU indication is lit. The message "PS" is canceled.
- ③ Press the PU/EXT key to change to the external operation mode. The EXT indication is lit.
- ④ Turn on the STF or STR signal.

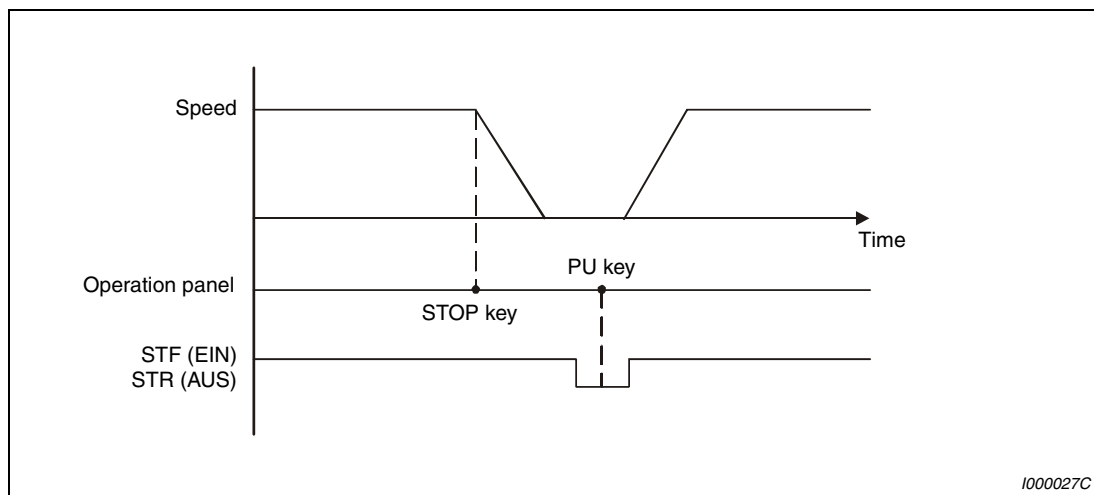

Fig. 6-98: Stop during external operation

Parameter unit (FR-PU04/FR-PU07)

- ① After completion of deceleration to a stop, switch off the STF or STR signal.
- ② Press the EXT key. The message "PS" is canceled.
- ③ Switch on the STF or STR signal.

The motor can be restarted by making a reset using a power supply reset or RES signal.

NOTE

If Pr. 250 "Stop selection" is set to other than "9999" to select coasting to a stop, the motor will not be coasted to a stop but decelerated to a stop by the PU stop function during external operation.

Restart (PS reset) method when PU stop (PS display) is made during PU operation

PU stop (PS display) is made when the motor is stopped from the unit where control command source is not selected (operation panel, parameter unit (FR-PU04/FR-PU07, operation panel for FR-E500 (PA02)) in the PU operation mode.

For example, when Pr. 551 "PU mode operation command source selection" = 9999 (initial value), the motor is stopped from the PU (PS display) if entered from the operation panel in PU operation mode with the parameter unit mounted.

When the motor is stopped from the PU when the parameter unit (FR-PU04/FR-PU07) is selected as control command source

- ① After the motor has decelerated to a stop, press the STOP key of the parameter unit (FR-PU04/FR-PU07).
- ② Press the PU/EXT key to change to the external operation mode. The EXT indication is lit. The message "PS" is canceled.
- ③ Press the PU key of the parameter unit (FR-PU04/FR-PU07) to select the PU operation mode.
- ④ Press the FWD or the REV key of the parameter unit (FR-PU04/FR-PU07).

NOTE

When Pr. 551 = "9999", the priorities of the PU control source is USB connector > parameter unit (FR-PU04/FR-PU07) > operation panel.

**CAUTION:**

Do not reset the inverter while the start signal is being input. Otherwise, the motor will start instantly after resetting, leading to potentially hazardous conditions.

6.17.2 Parameter write selection (Pr. 77)

You can select whether write to various parameters can be performed or not. Use this function to prevent parameter values from being rewritten by misoperation.

| Pr. No. | Name | Initial Value | Setting Range | Description | Parameters referred to | Refer to Section |
|---------|---------------------------|---------------|---------------|--|-----------------------------|------------------|
| 77 | Parameter write selection | 0 | 0 | Write is enabled only during a stop. | 79 Operation mode selection | 6.18.1 |
| | | | 1 | Parameter write is not enabled. | | |
| | | | 2 | Parameter write is enabled in any operation mode regardless of operation status. | | |

The above parameter can be set when Pr. 160 "User group read selection" = 0.

Pr. 77 can be always set independently of the operation mode and operation status.

Write parameters only at a stop (Pr. 77 = 0)

Parameters can be written only during a stop in the PU operation mode.

The half-tone screened parameters in the parameter list (Tab. 6-1) can always be written, regardless of the operation mode and operation status. However, Pr. 72 "PWM frequency selection" and Pr. 240 "Soft-PWM operation selection" can be written during operation in the PU operation mode, but cannot be written in external operation mode.

Disable parameter write (Pr. 77 = 1)

Parameter write is not enabled. (Reading is enabled.)

Parameter clear and all parameter clear cannot be performed, either.

The parameters given below can be written if Pr. 77 = 1.

| Parameter | Name |
|-----------|---|
| 22 | Stall prevention operation level |
| 75 | Reset selection/disconnected PU detection/PU stop selection |
| 77 | Parameter write selection |
| 79 | Operation mode selection |
| 160 | User group read selection |

Tab. 6-50: Parameters that can be written even if Pr. 77 = 1

Write parameters during operation (Pr. 77 = 2)

Parameters can always be written. The following parameters cannot be written during operation if Pr. 77 = 2. Stop operation when changing their parameter settings.

| Parameter | Bezeichnung |
|-----------|--|
| 19 | Base frequency voltage |
| 23 | Stall prevention operation level compensation factor at double speed |
| 40 | RUN key rotation direction selection |
| 48 | Second stall prevention operation current |
| 60 | Energy saving control selection |
| 61 | Reference current |
| 66 | Stall prevention operation reduction starting frequenc |
| 71 | Applied motor |
| 79 | Operation mode selection |
| 80 | Motor capacity (simple magnetic flux vector control) |
| 81 | Number of motor poles |
| 82 | Motor excitation current |
| 83 | Motor rated voltage |
| 84 | Rated motor frequency |
| 90–94 | Motor constants |
| 96 | Auto tuning setting/status |
| 178–184 | Input terminal function selection |
| 190–192 | Output terminal function selection |
| 255 | Life alarm status display |
| 256 | Inrush current limit circuit life display |
| 257 | Control circuit capacitor life display |
| 258 | Main circuit capacitor life display |
| 277 | Stall prevention operation current switchover |
| 292 | Automatic acceleration/deceleration |
| 293 | Acceleration/deceleration separate selection |
| 298 | Frequency search gain |
| 329 | Digital input unit selection (Parameter for the plug-in option FR-A7AX E kit) |
| 343 | Communication error count |
| 450 | Second applied motor |
| 541 | Frequency command sign selection (CC-Link) (Parameter for the plug-in option FR-A7NC E kit) |
| 563 | Energization time carrying-over times |
| 564 | Operating time carrying-over times |
| 800 | Control method selection |
| 859 | Torque current |

Tab. 6-51: Parameters that cannot be written during operation

6.17.3 Reverse rotation prevention selection (Pr. 78)

In some applications (fans, pumps) it is necessary to ensure that the motor cannot be reversed. This can be achieved with Pr. 78.

| Pr. No. | Name | Initial Value | Setting Range | Description | Parameters referred to | Refer to Section |
|-----------|---------------------------------------|---------------|---------------|--|------------------------|------------------|
| 78 | Reverse rotation prevention selection | 0 | 0 | Both forward and reverse rotations allowed | — | |
| | | | 1 | Reverse rotation disabled | | |
| | | | 2 | Forward rotation disallowed | | |

The above parameter can be set when Pr. 160 "User group read selection" = 0.

Set this parameter when you want to limit the motor rotation to only one direction.

This parameter is valid for all of the reverse rotation and forward rotation keys of the operation panel and parameter unit (FR-PU04/FR-PU07), the start signals (STF, STR signals) via external terminals, and the forward and reverse rotation commands through communication.

6.17.4 User groups (Pr. 160, Pr. 172 to Pr. 174)

Parameter which can be read from the operation panel and parameter unit can be restricted. In the initial setting, only the simple mode parameters are displayed.

| Pr. No. | Name | Initial Setting | Setting Range | Description | Parameters referred to | Refer to Section |
|------------|---|-----------------|---------------|---|---|------------------|
| 160 | User group read selection | 0 | 9999 | Only the simple mode parameters can be displayed. | 550 NET mode operation command source selection 551 PU mode operation command source selection | 6.18.3 6.18.3 |
| | | | 0 | The simple mode and extended parameters can be displayed. | | |
| | | | 1 | Only parameters registered in the user group can be displayed. | | |
| 172 | User group registered display/batch clear ① | 0 | (0-16) | Displays the number of cases registered as a user group (Read only) | | |
| | | | 9999 | Batch clear the user group registration | | |
| 173 | User group registration ①② | 9999 | 0-999/9999 | Set the parameter numbers to be registered to the user group. | | |
| 174 | User group clear ①② | 9999 | 0-999/9999 | Set the parameter numbers to be cleared from the user group. | | |

- ① The above parameter can be set when Pr. 160 "User group read selection" = 0.
- ② The values read from Pr. 173 and Pr. 174 are always "9999".

Display of simple mode parameters and extended parameters (Pr. 160)

When Pr. 160 = "9999", only the simple mode parameters can be displayed on the operation panel and parameter unit (FR-PU04/FR-PU07). (Refer to the parameter list Tab. 6-1 for the simple mode parameters.)

Setting "0" to Pr. 160 enables the display of the simple mode parameters and extended parameters.

NOTES

- When a plug-in option is fitted to the inverter, the option parameters can also be read.
- When reading the parameters using the communication option, all parameters (simple mode, extended mode, parameters for options) can be read regardless of the Pr. 160 setting.
- When RS-485 communication is used to read the parameters, all parameters can be read, regardless of the Pr. 550 "NET mode operation command source selection", Pr. 551 "PU mode operation command source selection", regardless of Pr. 160 setting.

| Pr. 551 | Pr. 550 | Pr. 160 Valid/Invalid |
|---|--|--|
| 2 (PU) | — | Valid |
| 3 (USB) 9999 (auto-detect) (initial value) | 0 (communication option) | Valid |
| | 2 (PU) | Invalid (all readable) |
| | 9999 (auto-detect) (initial value) | With communication option: valid |
| | | Without communication option: invalid (all readable) |

Pr. 15 "Jog frequency", Pr. 16 "Jog acceleration/deceleration time", and Pr. 991 "PU contrast adjustment" are displayed as simple mode parameter when the parameter unit (FR-PU04/FR-PU07) is fitted.

User group function (Pr. 160, Pr. 172 to Pr. 174)

The user group function is designed to display only the parameters necessary for setting.

From among all parameters, a maximum of 16 parameters can be registered to a user group. When Pr. 160 is set to "1", only the parameters registered to the user group can be accessed. (Reading of parameters other than the user group registration is disabled.)

To register a parameter to the user group, set its parameter number to Pr. 173. To delete a parameter from the user group, set its parameter number to Pr. 174. To batch-delete the registered parameters, set Pr. 172 to "9999".

Registration of parameter to user group (Pr. 173)

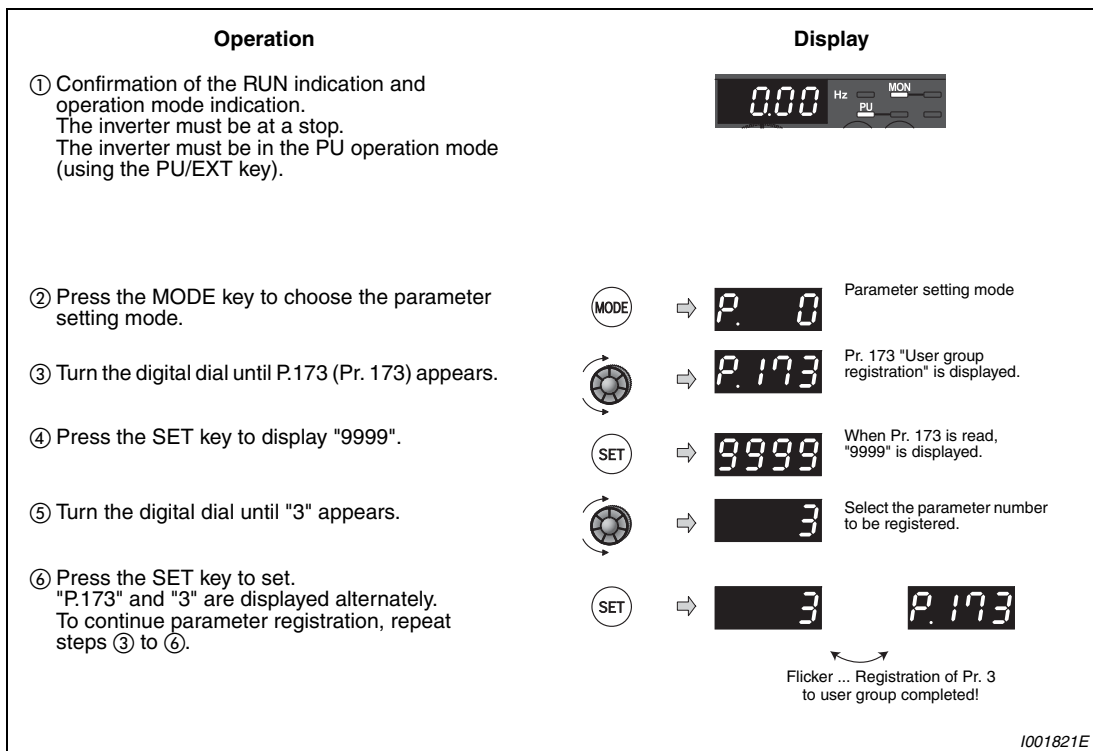

Fig. 6-99: When registering Pr. 3 to user group

Deletion of parameter from user group (Pr. 174)

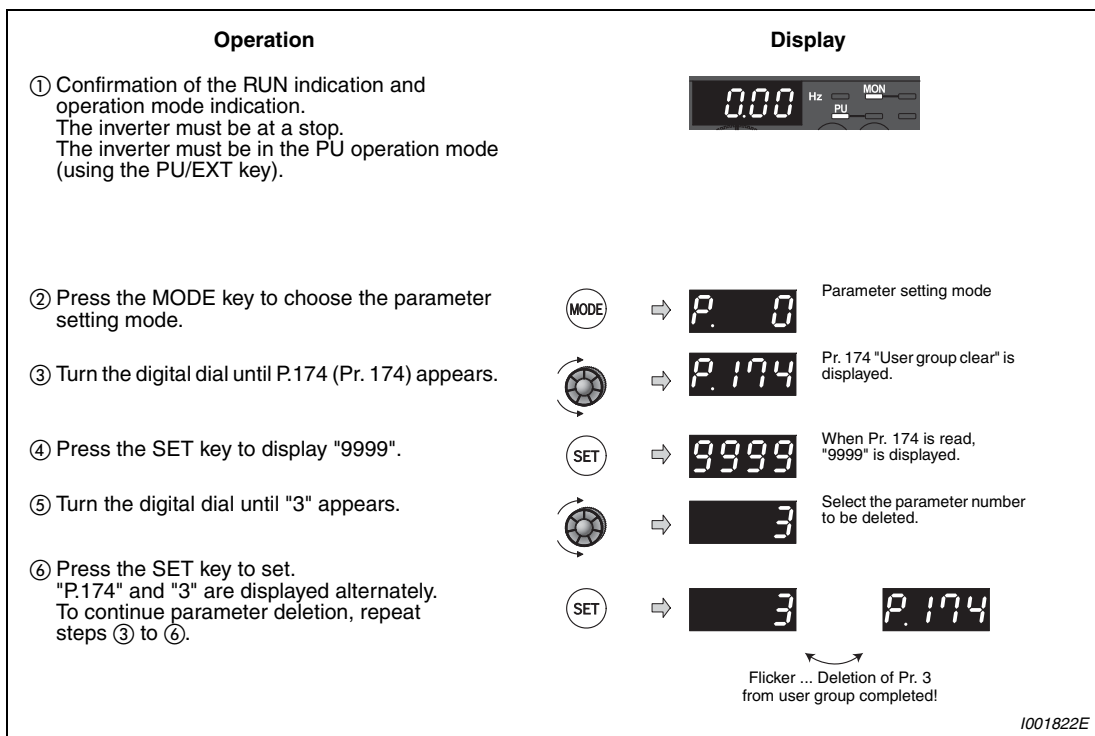

Fig. 6-100: When deleting Pr. 3 from user group

NOTES

- | Pr. 77, Pr. 160 and Pr. 991 can always be read, independently of the user group setting.
- | Pr. 77, Pr. 160 and Pr. 172 to Pr. 174 cannot be registered to the user group.
- | When Pr. 174 is read, "9999" is always displayed. Although "9999" can be written, no function is available.
- | When any value other than "9999" is set to Pr. 172, no function is available.

6.18 Selection of operation mode and operation location

| Purpose | Parameters that must be set | | Refer to Section |
|-----------------------------------|---|------------------------------------|------------------|
| Operation mode selection | Operation mode selection | Pr. 79 | 6.18.1 |
| Started in network operation mode | Operation mode at power on | Pr. 79, Pr. 340 | 6.18.2 |
| Selection of control source | Selection of control source, speed command source and control location during communication operation | Pr. 338, Pr. 339, Pr. 550, Pr. 551 | 6.18.3 |

6.18.1 Operation mode selection (Pr. 79)

Used to select the operation mode of the inverter.

Mode can be changed as desired between operation using external command signals (external operation), operation from the operation panel and PU (FR-PU07/FR-PU04) (PU operation), combined operation of PU operation and external operation (external/PU combined operation), and network operation (when RS-485 communication or acommunication option is used).

| Pr. No. | Name | Initial Value | Setting Range | Description | Parameters referred to | Refer to Section |
|---------|--------------------------|---------------|---------------|---|---------------------------|------------------|
| 79 | Operation mode selection | 0 | 0 | External/PU switchover mode External operation mode at power on | 15 Jog frequency | 6.6.2 |
| | | | 1 | Fixed to PU operation mode | 4-6 Multi-speed operation | 6.6.1 |
| | | | 2 | Fixed to external operation mode Operation can be performed by switching between external and NET operation mode | 24-27 232-239 75 | 6.17.1 |
| | | | 3 | Combined operation mode 1 Running frequency: Operation panel, and PU (FR-PU04/FR-PU07) setting or external signal input [multi-speed setting, across terminals 4-5 (valid when AU signal turns on)] Start signal: External signal input (terminal STF, STR) | 161 | 6.22.3 |
| | | | 4 | External/PU combined operation mode 2 Running frequency: External signal input (terminal 2, 4, JOG, multi-speed setting, etc.) Start signal: Enter from the RUN key of the operation panel and the FWD/REV keys of the PU (FR-PU04/FR-PU07) | 178-184 190-192 | 6.10.1 6.10.5 |
| | | | 6 | Switchover mode Switchover between PU operation, external operation, and NET operation is available while keeping the same operation status. | 340 | 6.18.2 |
| | | | 7 | External operation mode (PU operation interlock) X12 signal ON: Operation mode can be shifted to PU operation mode (output stop during external operation) X12 signal OFF: Operation mode can not be switched to PU operation mode. | 550 | 6.18.3 |

The above parameter can be changed during a stop in any operation mode.

Operation mode basics

The operation mode is to specify the source of inputting the start command and set frequency of the inverter.

- Select the "external operation mode" when performing operation by basically using the control circuit terminals and providing potentiometers, switches, etc. externally.
- Select the "PU operation mode" when inputting the start command and frequency setting through communication from the operation panel, parameter unit (FR-PU04/FR-PU07) or PU connector.
- Select the "network operation mode (NET operation mode)" when the commands are applied from the RS-485 communication with the PU connector or the network to the communication option card.

The operation mode can be selected from the operation panel or with the communication instruction code.

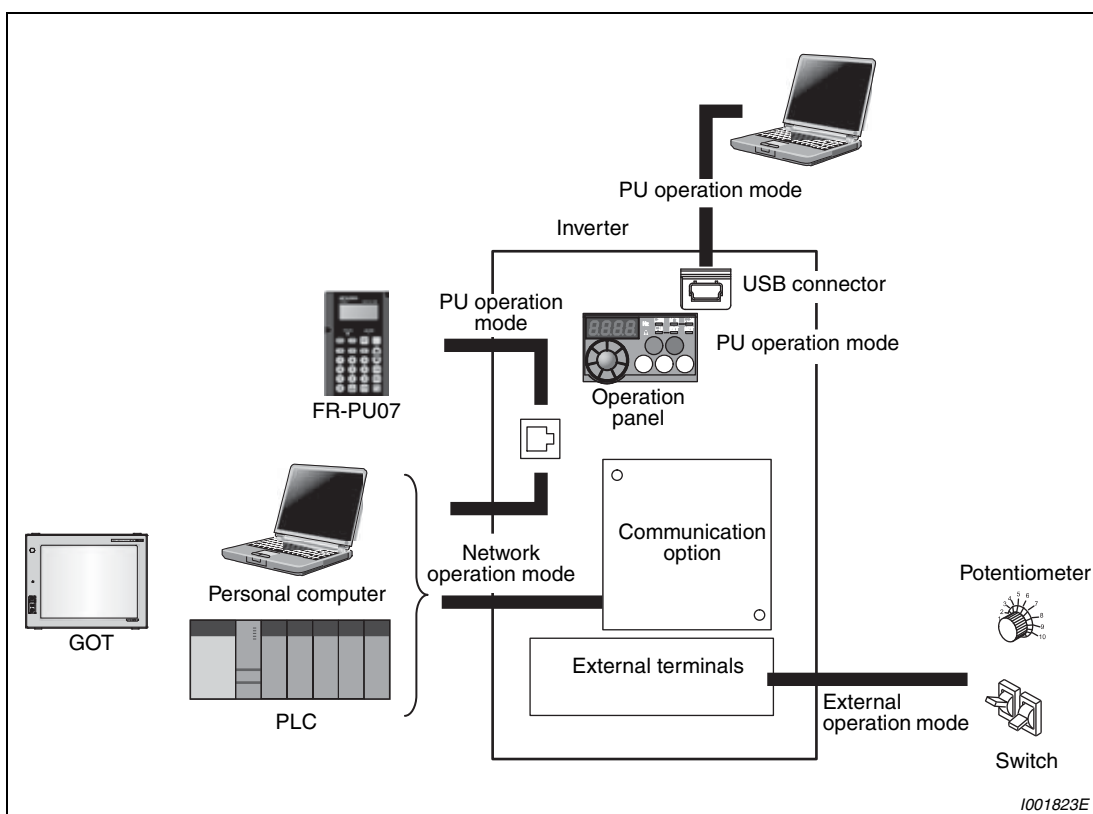

Fig. 6-101: Operation modes of the inverter

NOTES

Either "3" or "4" may be set to select the PU/external combined mode.

The stop function (PU stop selection) activated by pressing the STOP/RESET key of the operation panel and parameter unit (FR-PU04/FR-PU07) is valid even in other than the PU operation mode in the initial setting. (Refer to Pr. 75 "Reset selection/disconnected PU detection/PU stop selection" (section 6.17.1).)

Switching the operation mode

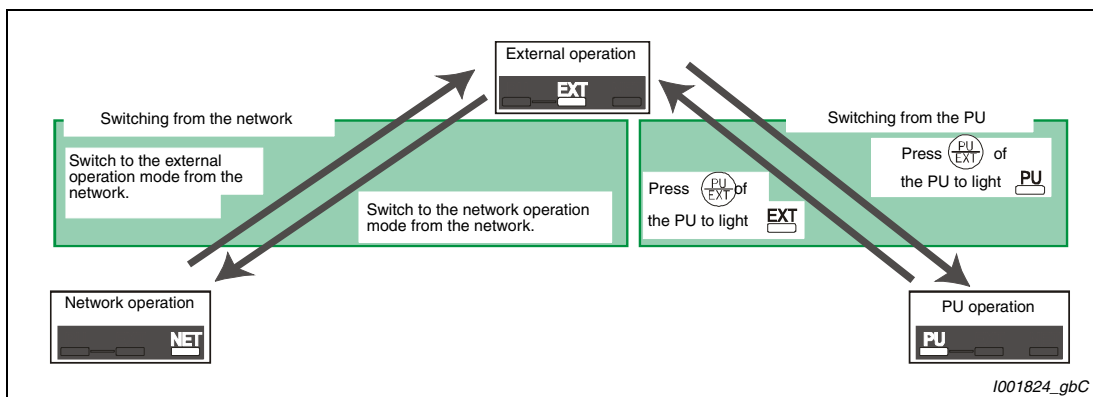

Fig. 6-102: Switching the operation mode when Pr. 340 = 0 or 1

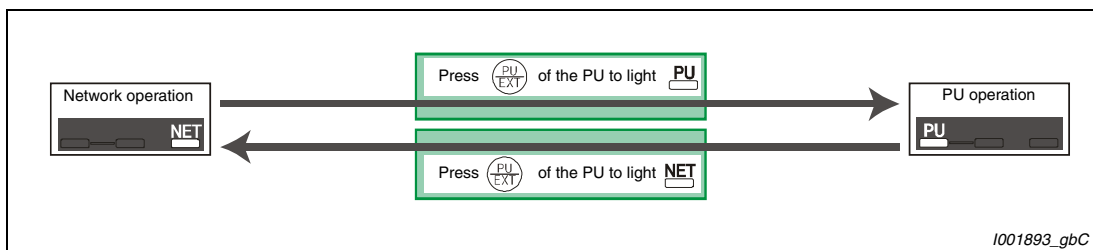

Fig. 6-103: Switching the operation mode when Pr. 340 = 10

NOTE

- For switching of operation by external terminals, refer to the following:
- PU operation external interlock signal (X12 signal) (refer to page 6-206)
 - PU-external operation switch-over signal (X16) (refer to page 6-207)
 - PU-NET operation switchover signal (X65) (refer to page 6-208)
 - External-NET operation switchover signal (X66) (refer to page 6-208)
 - Pr. 340 "Communication start-up mode selection" (refer to page 6-210)

Operation mode selection flow

In the following flowchart, select the basic parameter setting and terminal connection related to the operation mode:

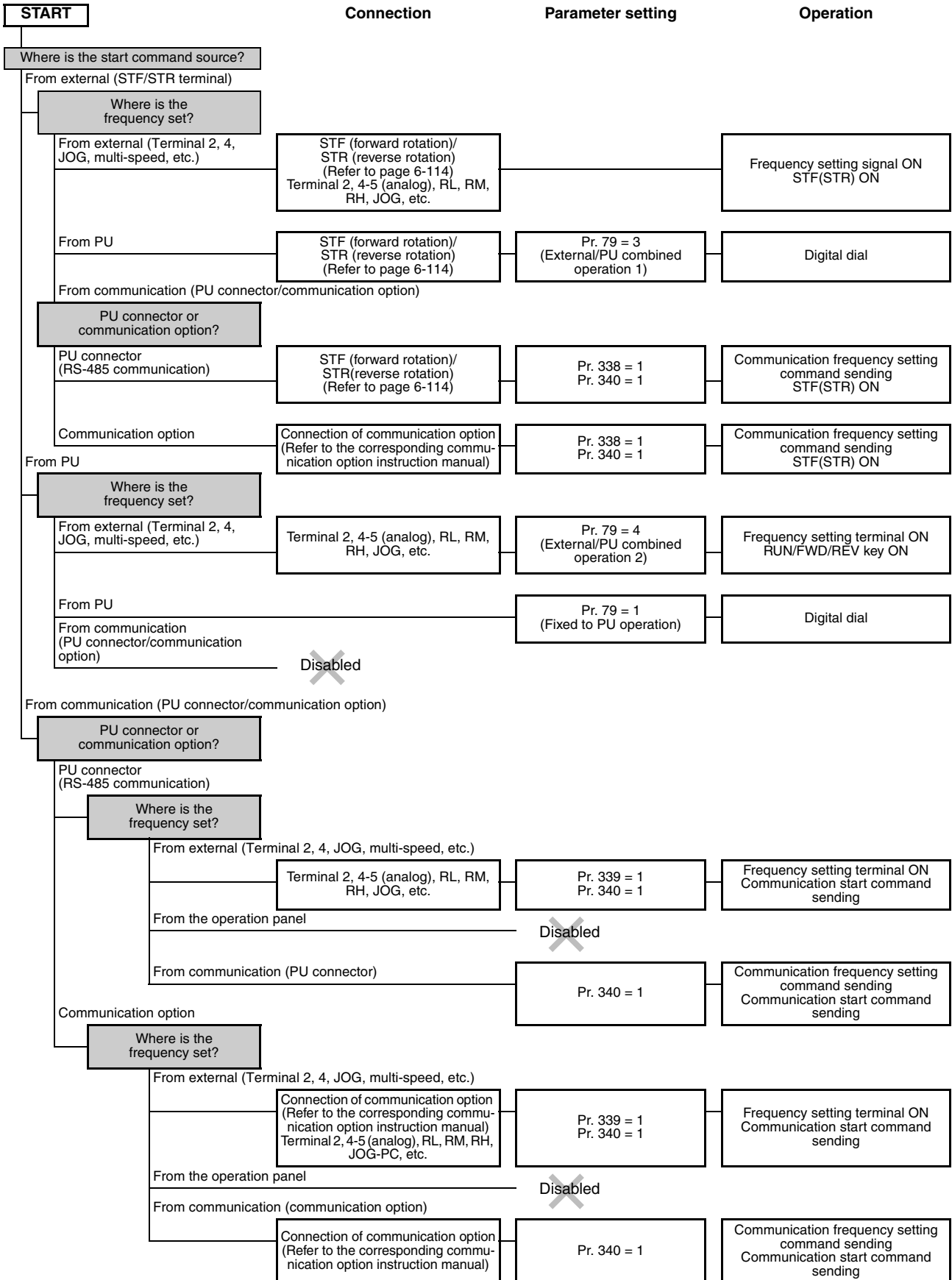

External operation mode (Pr. 79 = 0, 2)

Select the external operation mode when performing operation by providing a frequency setting potentiometer, start switch, etc. externally and connecting them to the control circuit terminals of the inverter.

Basically, parameter changing is disabled in external operation mode. (Some parameters can be changed. Refer to Tab. 6-1 for the parameter list.)

When "0" or "2" is selected for Pr. 79, the inverter enters the external operation mode at power on. (When using the network operation mode, refer to section 6.18.2).

If you don't need to change the parameter settings frequently you can set the unit to external mode permanently by setting Pr. 79 to "2". (If you need to change parameter settings frequently external mode should be activated by setting Pr. 79 to "0". Then the frequency inverter will switch to external mode automatically when the power is switched on but it can be switched to PU mode by pressing the PU/EXT key. You can then make the parameter changes in PU mode and switch back to external mode again afterwards by pressing PU/EXT again.)

The STF and STR signal are used as a start command, and the terminal 2, 4, multi-speed setting, JOG signal, etc. are used as frequency setting.

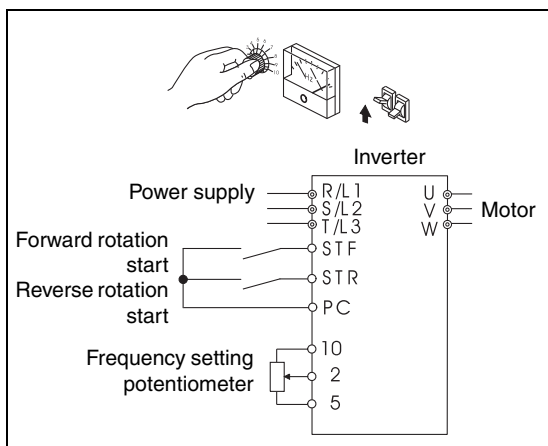

Fig. 6-104:
External operation mode

1001205E

PU operation mode (Pr. 79 = 1)

Select the PU operation mode when applying start and speed command by only the key operation of the operation panel (FR-PU04/FR-PU07). Also select the PU operation mode when making communication using the PU connector.

When "1" is selected for Pr. 79, the inverter enters the PU operation mode at power on. You cannot change to the other operation mode.

The setting dial of the operation panel can be used for setting like a volume. (Pr. 161 "Frequency setting/key lock operation selection", refer to section 6.22.3).

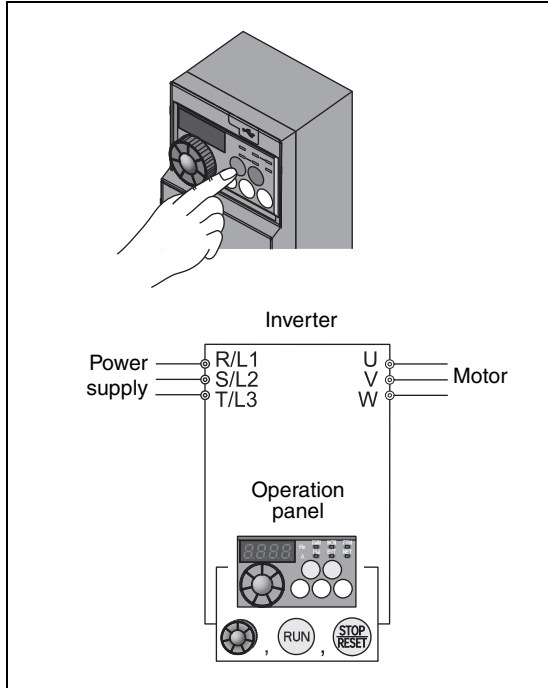

Fig. 6-105:
PU operation mode

1001825E

PU/external combined operation mode 1 (Pr. 79 = 3)

Select the PU/external combined operation mode 1 when applying frequency command from the operation panel or parameter unit (FR-PU04/FR-PU07) and inputting the start command with the external start switch.

Select "3" for Pr. 79. You cannot change to the other operation mode by using the PU/EXT-key.

When a frequency is input from the external signal by multi-speed setting, it has a higher priority than the frequency setting of the PU. When AU is on, the terminal 4 is used.

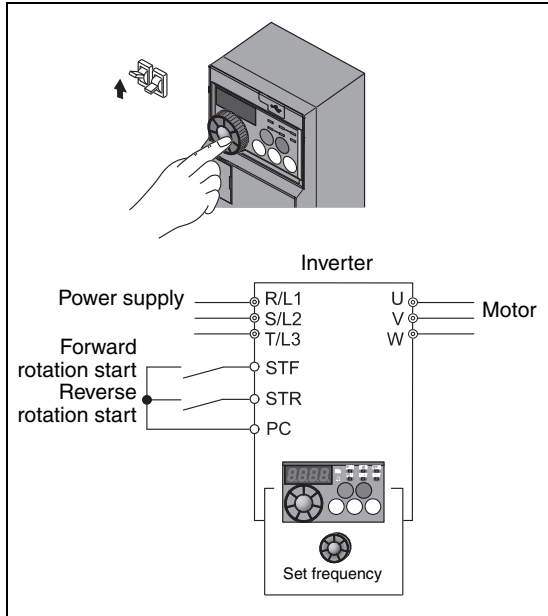

Fig. 6-106:
Combined operation mode 1

1001826E

PU/external combined operation mode 2 (Pr. 79 = 4)

Select the PU/external combined operation mode 2 when applying frequency command from the external potentiometer, multi-speed or JOG signal and inputting the start command by key operation of the operation panel (FR-PU04/FR-PU07).

Select "4" for Pr. 79. You cannot change to the other operation mode by using the PU/EXT-key.

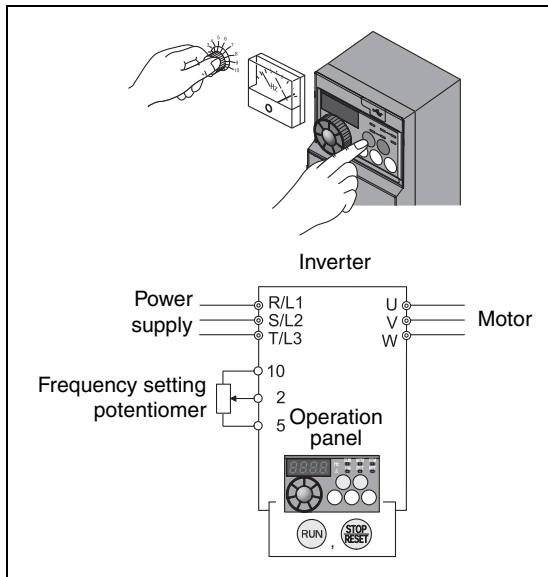

Fig. 6-107:
Combined operation mode 2

1001827E

Switch-over mode (Pr. 79 = 6)

While continuing operation, you can switch between the PU operation, external operation and network operation (when RS-485 communication with the PU connector or communication option is used).

| Operation Mode Switching | Switching Operation/Operating Status |
|------------------------------------|---|
| External operation ⇒ PU operation | Select the PU operation mode with the operation panel or parameter unit. Rotation direction is the same as that of external operation. The frequency set with the potentiometer (frequency command) or like is used unchanged. (Note that the setting will disappear when power is switched off or the inverter is reset.) |
| External operation ⇒ NET operation | Send the mode change command to the network operation mode through communication. Rotation direction is the same as that of external operation. The value set with the setting potentiometer (frequency command) or like is used unchanged. (Note that the setting will disappear when power is switched off or the inverter is reset.) |
| PU operation ⇒ external operation | Press the external operation key of the parameter unit. The rotation direction is determined by the input signal of the external operation. The set frequency is determined by the external frequency command signal. |
| PU operation ⇒ NET operation | Send the mode change command to the network operation mode through communication. Rotation direction and set frequency are the same as those of PU operation. |
| NET operation ⇒ external operation | Command to change to external mode is transmitted by communication. Rotation direction is determined by the external operation input signal. The set frequency is determined by the external frequency command signal. |
| NET operation ⇒ PU operation | Select the PU operation mode with the operation panel or parameter unit. The rotation direction and frequency command in the network operation mode are used unchanged. |

Tab. 6-52: Operation states in the switch-over mode

**WARNING:**

When using switch-over mode please note that in some switch-over operations the rotation direction command and the frequency setting value are "transferred" to the "new" operating mode (refer to Tab. 6-52 for details). When this happens the drive will run in the new operating mode even though it has not (yet) received any control commands.

It is extremely important to take this into account and take the necessary steps to ensure that performing these switch-over operations cannot cause hazardous conditions.

PU operation interlock (Pr. 79 = 7)

The PU operation interlock function is designed to forcibly change the operation mode to external operation mode when the PU operation interlock signal (X12) input turns off.

This function prevents the inverter from being inoperative by the external command if the mode is accidentally left unswitched from the PU operation mode.

Set "7" (PU operation interlock) in Pr. 79. For the terminal used for X12 signal (PU operation interlock signal) input, set "12" to any of Pr. 178 to Pr. 184 "Input terminal function selection" to assign the function. (Refer to section 6.10.1 for Pr. 178 to Pr. 184.) When the X12 signal has not been assigned, the function of the MRS signal switches from MRS (output stop) to the PU operation interlock signal.

| X12 (MRS) Signal | Function/Operation | |
|------------------|---|--|
| | Operation mode | Parameter write |
| ON | Operation mode (external, PU, NET) switching enabled Output stop during external operation | Parameter write enabled (depending on Pr. 77 "Parameter write selection" and each parameter write condition (Refer to Tab. 6-1 for the parameter list.)) |
| OFF | Forcibly switched to external operation mode External operation allowed. Switching to PU or NET operation mode disabled | Parameter write disabled with exception of Pr. 79 |

Tab. 6-53: Function of the X12 signal

Function/operation changed by switching on-off the X12 (MRS) signal

| Operation Condition | | X12 (MRS) Signal | Operation Mode | Operating Status | Switching to PU, NET Operation Mode |
|---------------------|-------------|------------------|----------------|--|-------------------------------------|
| Operation mode | Status | | | | |
| PU/NET | During stop | ON → OFF ① | External ② | If external operation frequency setting and start signal are entered, operation is performed in that status. | Disallowed |
| | Running | ON → OFF ① | | | Disallowed |
| External | During stop | OFF → ON | External ② | Stop | Enabled |
| | | ON → OFF | | | Disallowed |
| | Running | OFF → ON | | During operation → output stop | Disallowed |
| | | ON → OFF | | Output stop → During operation | Disallowed |

Tab. 6-54: Switching the X12 (MRS) signal

- ① The operation mode switches to external operation mode independently of whether the start signal (STF, STR) is on or off. Therefore, the motor is run in external operation mode when the X12 (MRS) signal is turned off with either of STF and STR on.
- ② At alarm occurrence, pressing the STOP/RESET key of the operation panel resets the inverter.

NOTES

If the X12 (MRS) signal is on, the operation mode cannot be switched to PU operation mode when the start signal (STF, STR) is on.

When the MRS signal is used as the PU interlock signal, the MRS signal serves as the normal MRS function (output stop) by turning on the MRS signal and then changing the Pr. 79 value to other than "7" in the PU operation mode. Also as soon as "7" is set in Pr. 79, the signal acts as the PU interlock signal.

When the MRS signal is used as the PU operation interlock signal, the logic of the signal is as set in Pr. 17. When Pr. 17 = 2, read ON as OFF and OFF as ON in the above explanation.

Changing the terminal assignment using Pr. 178 to Pr. 184 "Input terminal function selection" may affect the other functions. Please make setting after confirming the function of each terminal.

Switching of operation mode by external terminal (X16)

When external operation and operation from the operation panel are used together, use of the PU-external operation switching signal (X16) allows switching between the PU operation mode and external operation mode during a stop (during a motor stop, start command off).

When Pr. 79 = any of "0, 6, 7", the operation mode can be switched between the PU operation mode and external operation mode. (Pr. 79 = 6 switch-over mode can be changed during operation)

For the terminal used for X16 signal input, set "16" to any of Pr. 178 to Pr. 184 "Input terminal function selection" to assign the function.

| Pr. 79 | X16 Signal State Operation Mode | | Remarks | |
|-------------------|-------------------------------------|-------------------------|--|--|
| | ON (external) | OFF (PU) | | |
| 0 (initial value) | External operation mode | PU operation mode | Can be switched to external, PU or NET operation mode | |
| 1 | PU operation mode | | Fixed to PU operation mode | |
| 2 | External operation mode | | Fixed to external operation mode (Can be switched to NET operation mode.) | |
| 3 / 4 | External/PU combined operation mode | | External/PU combined mode fixed | |
| 6 | External operation mode | PU operation mode | Can be switched to external, PU or NET operation mode with operation continued | |
| 7 | X12 (MRS) ON | External operation mode | PU operation mode | Can be switched to external, PU or NET operation mode. (Output stop in external operation mode.) |
| | X12 (MRS) OFF | External operation mode | | Fixed to external operation mode (Forcibly switched to external operation mode.) |

Tab. 6-55: Operation mode switching by signal X16

NOTES

The operation mode status changes depending on the setting of Pr. 340 "Communication start-up mode selection" and the ON/OFF states of the X65 and X66 signals. (For details, refer to page 6-208).

The priorities of Pr. 79, Pr. 340 and signals are:
Pr. 79 > X12 > X66 > X65 > X16 > Pr. 340

Changing the terminal assignment using Pr. 178 to Pr. 184 "Input terminal function selection" may affect the other functions. Please make setting after confirming the function of each terminal.

Switching of operation mode by external terminal (X65, X66)

When Pr. 79 = any of "0, 2, 6", the operation mode switching signals (X65, X66) can be used to change the PU or external operation mode to network operation mode during a stop (during a motor stop or start command off). (Pr. 79 = 6 switch-over mode can be changed during operation)

When switching between the network operation mode and PU operation mode:

- ① Set Pr. 79 to "0" (initial value) or "6".
- ② Set "10" in Pr. 340 "Communication start-up mode selection".
- ③ Set "65" to any of Pr. 178 to Pr. 184 to assign the PU-NET operation switching signal (X65) to the external terminal.
- ④ The operation mode changes to PU operation mode when the X65 signal turns on, or to network operation mode when the X65 signal turns off.

| Pr. 340 | Pr. 79 | X65 Signal State | | Remarks | |
|---------|------------------------|-------------------------------------|---|--|--|
| | | ON (PU) | OFF (NET) | | |
| 10 | 0 (initial setting) | PU operation mode ① | NET operation mode ② | Cannot be switched to external operation mode | |
| | 1 | PU operation mode | | Fixed to PU operation mode | |
| | 2 | NET operation mode | | Fixed to NET operation mode | |
| | 3 / 4 | External/PU combined operation mode | | External/PU combined mode fixed | |
| | 6 | PU operation mode ① | NET operation mode ② | Operation mode can be switched with operation continued Cannot be switched to external operation mode | |
| | 7 | X12 (MRS) ON | Switching among the External and PU operation mode is enabled ③ | | Output stop in external operation mode |
| | | X12 (MRS) OFF | External operation mode | | Forcibly switched to external operation mode |

Tab. 6-56: Operation mode switching by signal X65

- ① NET operation mode when the X66 signal is on.
- ② PU operation mode is selected when the X16 signal is off. PU operation mode also when Pr. 550 "NET mode operation command source selection" = 0 (communication option control source) and the communication option is not fitted.
- ③ External operation mode when the X16 signal is on.

When switching between the network operation mode and external operation mode:

- ① Set Pr. 79 to "0" (initial value), "2", "6" or "7". (At the Pr. 79 setting of "7", the operation mode can be switched when the X12 (MRS) signal turns on.)
- ② Set "0 (initial value) or 1" in Pr. 340 "Communication startup mode selection".
- ③ Set "66" to any of Pr. 178 to Pr. 184 to assign the external-NET operation switching signal (X66) to the external terminal.
- ④ The operation mode changes to network operation mode when the X66 signal turns on, or to external operation mode when the X66 signal turns off.

| Pr. 340 | Pr. 79 | X66-Signal | | Remarks | |
|----------------------------|-------------------|-------------------------------------|---------------------------|---|--|
| | | ON (PU) | OFF (NET) | | |
| 0 (initial value)/ 1 | 0 (initial value) | NET operation mode ① | External operation mode ② | | |
| | 1 | PU operation mode | | Fixed to PU operation mode | |
| | 2 | NET operation mode ① | External operation mode | Cannot be switched to PU operation mode | |
| | 3 / 4 | External/PU combined operation mode | | External/PU combined mode fixed | |
| | 6 | NET operation mode ① | External operation mode ② | Operation mode can be switched with operation continued | |
| | 7 | X12 (MRS) ON | NET operation mode ① | External operation mode ② | Output stop in external operation mode |
| | | X12 (MRS) OFF | External operation mode | | Forcibly switched to external operation mode |

Tab. 6-57: Operation mode switching by signal X66

- ① PU operation mode also when Pr. 550 "NET mode operation command source selection" = 1 (communication option control source) and the communication option is not fitted.
- ② PU operation mode when the X16 signal is off. When the X65 signal has been assigned, the operation mode changes with the ON/OFF state of the X65 signal.

NOTES

The priorities of Pr. 79, Pr. 340 and signals are:
Pr. 79 > X12 > X66 > X65 > X16 > Pr. 340

Changing the terminal assignment using Pr. 178 to Pr. 184 "Input terminal function selection" may affect the other functions. Please make setting after confirming the function of each terminal.

6.18.2 Operation mode at power on (Pr. 79, Pr. 340)

When power is switched on or when power comes back on after instantaneous power failure, the inverter can be started up in network operation mode.

After the inverter has started up in the network operation mode, parameter write and operation can be performed from a program.

Set this mode for communication operation using the inverter RS-485 terminals or communication option.

| Pr. No. | Name | Initial Value | Setting Range | Description | Parameters referred to | Refer to Section |
|------------|--|---------------|---------------|---|-----------------------------|------------------|
| 79 | Operation mode selection | 0 | 0-4/6/7 | Select the operation mode. (Refer to page 6-201) | 79 Operation mode selection | 6.18.1 |
| 340 | Communication start-up mode selection ^① | 0 | 0 | As set in Pr. 79. | | |
| | | | 1 | Started in network operation mode. | | |
| | | | 10 | Started in network operation mode. Operation mode can be changed between the PU operation mode and network operation mode from the operation panel. | | |

The above parameters can be changed during a stop in any operation mode.

- ① The above parameter can be set when Pr. 160 "User group read selection" = 0. However, the parameters can be set whenever the communication option is connected. (Refer to section 6.17.4.)

Specify operation mode at power on (Pr. 340)

Depending on the Pr. 79 and Pr. 340 settings, the operation mode at power on (reset) changes as described below:

| Pr. 340 | Pr. 79 | Operation Mode at Power on, Power Restoration, Reset | Operation Mode Switching |
|---|----------------------|--|--|
| 0 (initial value) | 0 (initial value) | External operation mode | Can be switched to external, PU or NET operation mode ① |
| | 1 | PU operation mode | Fixed to PU operation mode |
| | 2 | External operation mode | Can be switched to external or NET operation mode Switching to PU operation mode disabled |
| | 3 / 4 | External/PU combined operation mode | Operation mode switching disabled |
| | 6 | External operation mode | Can be switched to external, PU or NET operation mode with operation continued |
| | 7 | X12 (MRS) signal ON: External operation mode | Can be switched to external, PU or NET operation mode ① |
| X12 (MRS) signal OFF: External operation mode | | Fixed to external operation mode (Forcibly switched to external operation mode.) | |
| 1 | 0 | NET operation mode | Same as when Pr. 340 = 0 |
| | 1 | PU operation mode | |
| | 2 | NET operation mode | |
| | 3 / 4 | External/PU combined operation mode | |
| | 6 | NET operation mode | |
| | 7 | X12 (MRS) signal ON: NET operation mode | |
| X12 (MRS) signal OFF: External operation mode | | | |
| 10 | 0 | NET operation mode | Can be switched to PU or NET operation mode ② |
| | 1 | PU operation mode | Same as when Pr. 340 = 0 |
| | 2 | NET operation mode | Fixed to NET operation mode |
| | 3 / 4 | External/PU combined operation mode | Same as when Pr. 340 = 0 |
| | 6 | NET operation mode | Can be switched to PU or NET operation mode with operation continued ② |
| | 7 | External operation mode | Same as when Pr. 340 = 0 |

Tab. 6-58: Operation mode of the inverter at power on

- ① The operation mode cannot be switched directly between the PU operation mode and network operation mode.
- ② Operation mode can be changed between the PU operation mode and network operation mode with the PU/EXT key of the operation panel and X65 signal.

6.18.3 Start command source and frequency command source during communication operation (Pr. 338, Pr. 339, Pr. 550, Pr. 551)

When the RS-485 communication with the PU connector or communication option is used, the external start command and frequency command can be made valid. Command source in the PU operation mode can be selected.

From the communication device, parameter unit, etc. which have command source, parameter write or start command can be executed. Parameter read or monitoring can be executed in any operation mode.

| Pr. No. | Name | Initial Value | Setting Range | Description | Parameters referred to | Refer to Section |
|---------|---|---------------|---------------|---|--|--------------------------|
| 338 | Communication operation command source | 0 | 0 | Start command source communication | 59 Remote function selection 79 Operation mode selection 270 Stop-on contact control selection | 6.6.3 6.18.1 6.9.4 |
| | | | 1 | Start command source external | | |
| 339 | Communication speed command source | 0 | 0 | Frequency command source communication | | |
| | | | 1 | Frequency command source external (Frequency command from communication is invalid, frequency command from terminal 2 is valid) | | |
| | | | 2 | Frequency command source external (Frequency command from communication is valid, frequency command from terminal 2 is invalid) | | |
| 550 | NET mode operation command source selection ① | 9999 | 0 | The communication option is the command source when NET operation mode. | | |
| | | | 2 | PU connector is the command source when NET operation mode. | | |
| | | | 9999 | Automatic communication option recognition Normally, PU connector is the command source. When a communication option is mounted, the communication option is the command source. | | |
| 551 | PU mode operation command source selection ① | 2 | 2 | PU connector is the command source when PU operation mode. | | |
| | | | 3 | USB connector is the command source when PU operation mode. | | |
| | | | 4 | Operation panel is the command source when PU operation mode. | | |
| | | | 9999 | USB automatic recognition Normally, operation panel is the command source. When the parameter unit is connected to the PU connector, PU is the command source. When USB is connected, USB connector is the command source. | | |

The above parameters can be set when Pr. 160 "User group read selection" = 0. However, the parameters can be set whenever the communication option is connected. (Refer to section 6.17.4.)

① Pr. 550 and Pr. 551 are always write-enabled.

Select the command source of the network operation mode (Pr. 550)

Either the RS-485 communication with the PU connector or communication option can be specified as the command source in the network operation mode.

For example, set Pr. 550 to "2" when executing parameter write, start command or frequency command from the unit RS-485 terminals in the network operation mode independently of whether the communication option is connected or not.

NOTE

Since Pr. 550 = 9999 (automatic communication option recognition) in the initial setting, parameter write, start command and frequency command cannot be executed by communication using the unit RS-485 terminals when the communication option is fitted.

Selects the command source of the PU operation mode (Pr. 551)

Any of the operation panel, PU connector, or USB connector can be specified as the command source in the PU operation mode.

In the PU operation mode, set Pr. 551 to "2" when executing parameter write, start command or frequency command during the RS-485 communication with PU communication.

NOTES

When performing the RS-485 communication with the PU connector when Pr. 551 = 9999, PU mode command source does not automatically change to the PU connector. Change to the network operation mode to change the command source.

When "2" (NET mode PU connector) is set in Pr. 550 and "2" (PU mode PU connector) is set in Pr. 551, PU operation mode has priority. When the communication option is not fitted, therefore, the operation mode cannot be switched to the network operation mode.

Changed setting value is made valid when powering on or resetting the inverter.

The Modbus-RTU protocol cannot be used in the PU operation mode. Select network operation mode (NET mode command source).

All of the operation mode indicator (**PU** **EXT** **NET**) of the operation panel turns OFF when command source is not operation panel.

| Pr. 550 | Pr. 551 | Command Source | | | | | Remarks |
|----------------------|----------------------|-----------------|-----------------|-----------------|----------------------|---------------------------------|--|
| | | Operation panel | USB connector | PU connector | | Communication option | |
| | | | | Parameter unit | RS-485 communication | | |
| 0 | 2 | — | — | PU | PU ^① | NET ^② | |
| | 3 | — | PU | — | — | NET ^② | |
| | 4 | PU | — | — | — | NET ^② | |
| | 9999 (initial value) | PU ^③ | PU ^③ | PU ^③ | — | NET ^② | |
| 2 | 2 | — | — | PU | PU ^① | — | Switching to NET operation mode disabled |
| | 3 | — | PU | — | NET | — | |
| | 4 | PU | — | — | NET | — | |
| | 9999 (initial value) | PU ^③ | PU ^③ | PU ^③ | NET | — | |
| 9999 (initial value) | 2 | — | — | PU | PU ^① | NET ^② | |
| | 3 | — | PU | — | — | NET ^② | Communication option fitted |
| | | | | — | NET | — | Communication option not fitted |
| | 4 | PU | — | — | — | NET ^② | Communication option fitted |
| | | | | — | NET | — | Communication option not fitted |
| | 9999 (initial value) | PU ^③ | PU ^③ | PU ^③ | — | NET ^② | Communication option fitted |
| — | | | | NET | — | Communication option not fitted | |

Tab. 6-59: Parameter 550 and 551 settings

- ① The Modbus-RTU protocol cannot be used in the PU operation mode. When using the Modbus-RTU protocol, set Pr. 550 to "2".
- ② When the communication option is not fitted, the operation mode cannot be switched to the network operation mode.
- ③ When Pr. 551 = 9999, the priorities of the PU control source is USB connector > parameter unit (FR-PU04/FR-PU07) > operation panel.

Controllability through communication

| Operation Location | Condition (Pr. 551) | Command | Operation Mode | | | | | |
|---|--|---------------------------|----------------|--------------------|--|--|---|---|
| | | | PU operation | External operation | External/PU combined operation mode 1 (Pr. 79 = 3) | External/PU combined operation mode 2 (Pr. 79 = 4) | NET operation (when using PU connector) ⑥ | NET operation (when communication option is used) ⑦ |
| Control by RS-485 communication from PU connector | 2 (PU connector) | Run command (start) | ✓ | — | — | ✓ | — | |
| | | Run command (stop) | ✓ | ◇ ^③ | ◇ ^③ | ✓ | ◇ ^③ | |
| | | Running frequency setting | ✓ | — | ✓ | — | — | |
| | | Parameter write | ✓ ^④ | — ^⑤ | ✓ ^④ | ✓ ^④ | — ^⑤ | |
| | | Inverter reset | ✓ | ✓ | ✓ | ✓ | ✓ | |
| | Other than the above | Run command (start) | — | — | — | — | ✓ ^① | — |
| | | Run command (stop) | — | — | — | — | ✓ ^① | — |
| | | Running frequency setting | — | — | — | — | ✓ ^① | — |
| | | Parameter write | — ^⑤ | — ^⑤ | — ^⑤ | — ^⑤ | ✓ ^④ | — ^⑤ |
| | | Inverter reset | — | — | — | — | ✓ ^② | — |
| Operation from the USB connector | 3 (USB connector) 9999 (automatic recognition) | Run command (start, stop) | ✓ | — | — | ✓ | — | |
| | | Running frequency setting | ✓ | — | ✓ | — | — | |
| | | Parameter write | ✓ ^④ | — ^⑤ | — ^⑤ | — ^⑤ | — ^⑤ | |
| | | Inverter reset | ✓ | ✓ | ✓ | ✓ | ✓ | |
| | Other than the above | Run command (start, stop) | — | — | — | — | — | |
| | | Running frequency setting | — | — | — | — | — | |
| | | Parameter write | — ^⑤ | — ^⑤ | — ^⑤ | — ^⑤ | — ^⑤ | |
| | | Inverter reset | ✓ | ✓ | ✓ | ✓ | ✓ ^② | — |

Tab. 6-60: Functions in the single operation modes (1)

| Operation Location | Condition (Pr. 551) | Command | Operation Mode | | | | | NET operation (when using PU connector) ⑥ | NET operation (when communication option is used) ⑦ |
|--|---------------------|---------------------------|----------------|--------------------|--|--|-----|---|---|
| | | | PU operation | External operation | External/PU combined operation mode 1 (Pr. 79 = 3) | External/PU combined operation mode 2 (Pr. 79 = 4) | | | |
| Control by communication from communication option | — | Run command (start, stop) | — | — | — | — | — | ✓ ① | |
| | | Running frequency setting | — | — | — | — | — | ✓ ① | |
| | | Parameter write | — ⑤ | — ⑤ | — ⑤ | — ⑤ | — ⑤ | ✓ ④ | |
| | | Inverter reset | — | — | — | — | — | ✓ ② | |
| Control circuit external terminals | — | Inverter reset | ✓ | ✓ | ✓ | ✓ | ✓ | | |
| | | Run command (start, stop) | — | ✓ | ✓ | — | — ① | | |
| | | Running frequency setting | — | ✓ | — | ✓ | — ① | | |

Tab. 6-60: Functions in the single operation modes (2)

✓: enabled

—: not enabled

◇: some are enabled

① As set in Pr. 338 "Communication operation command source" and Pr. 339 "Communication speed command source".

② At occurrence of RS-485 communication error, the inverter cannot be reset from the computer.

③ Enabled only when stopped by the PU. At a PU stop, "PS" is displayed on the operation panel. As set in Pr. 75 "Reset selection/disconnected PU detection/PU stop selection". (Refer to section 6.17.1.)

④ Some parameters may be write-disabled according to the Pr. 77 "Parameter write selection" setting and operating status. (Refer to section 6.17.2).

⑤ Some parameters are write-enabled independently of the operation mode and command source presence/absence. When Pr. 77 = 2, write is enabled. (Refer to Tab. 6-1 for the parameter list.) Parameter clear is disabled.

⑥ When Pr. 550 "NET mode operation command source selection" = 2 (PU connector valid) or Pr. 550 "NET mode operation command source selection" = 9999 and the communication option is not fitted.

⑦ When Pr. 550 "NET mode operation command source selection" = 0 (communication option valid) or Pr. 550 "NET mode operation command source selection" = 9999 and the communication option is fitted.

Operation at alarm occurrence

| Alarm Definition | Condition (Pr. 551) | Operation Mode | | | | | |
|--|---|-------------------|--------------------|---|---|--|--|
| | | PU operation | External operation | External/PU combined operation mode 1 (Pr. 79 = 3) | External/PU combined operation mode 2 (Pr. 79 = 4) | NET operation (when using PU connector) ⑤ | NET operation (when communication option is used) ⑥ |
| Inverter fault | — | Stop | | | | | |
| PU disconnection of the PU connector | 2 (PU connector) 9999 (automatic recognition) | Stop/continued ①④ | | | | | |
| | Other than the above | Stop/continued ① | | | | | |
| RS-485 communication error of the PU connector | 2 (PU connector) | Stop/continued ② | Continued | Stop/continued ② | — | Continued | |
| | Other than the above | Continued | | | Stop/continued ③ | Continued | |
| Communication error of USB connector | 3 (USB connector) 9999 (automatic recognition) | Stop/continued ② | Continued | Stop/continued ② | Continued | | |
| | Other than the above | Continued | | | | | |
| Communication alarm of communication option | — | Continued | | | Stop/continued ③ | Continued | |

Tab. 6-61: Operation at alarm occurrence

- ① Can be selected using Pr. 75 "Reset selection/disconnected PU detection/PU stop selection"
- ② Can be selected using Pr. 122 "PU communication check time interval" and Pr. 548 "USB communication check time interval".
- ③ As controlled by the communication option.
- ④ In the PU JOG operation mode, operation is always stopped when the PU is disconnected. Whether fault (E.PUE) occurrence is allowed or not is as set in Pr. 75 "Reset selection/disconnected PU detection/PU stop selection".
- ⑤ When Pr. 550 "NET mode operation command source selection" = 2 (PU connector valid) or Pr. 550 "NET mode operation command source selection" = 9999 and the communication option is not fitted.
- ⑥ When Pr. 550 "NET mode operation command source selection" = 0 (communication option valid) or Pr. 550 "NET mode operation command source selection" = 9999 and the communication option is fitted.

Selection of control source in network operation mode (Pr. 338, Pr. 339)

As control sources, there are the operation command source that controls the signals related to the inverter start command and function selection and the speed command source that controls the signals related to frequency setting.

In network operation mode, the commands from the external terminals and communication (PU connector or communication option) are as listed below.

| Operation Location Selection | Communication operation command source (Pr. 338) | | 0: NET | | | 1: External | | | Remarks | | |
|--|--|-----------------------------------|--|-------------|-------------|-------------|-------------|-------------|----------|--|--|
| | Communication speed command source (Pr.339) | | 0: NET | 1: External | 2: External | 0: NET | 1: External | 2: External | | | |
| Fixed function (Terminal-equivalent function) | Running frequency from communication | | NET | — | NET | NET | — | NET | | | |
| | Terminal 2 | | — | External | — | — | External | — | | | |
| | Terminal 4 | | — | External | | — | External | | | | |
| Selective function Pr. 178 to Pr. 184 setting | 0 | RL | Low speed operation command/remote setting clear/stop-on contact selection 0 | | NET | External | | NET | External | | Pr. 59 = 0 (multi-speeds) Pr. 59 = 1, 2 (remote) Pr. 270 = 1 (stop-on-contact 0) |
| | 1 | RM | Middle-speed operation command/remote setting deceleration | | NET | External | | NET | External | | |
| | 2 | RH | High speed operation command/remote setting acceleration | | NET | External | | NET | External | | |
| | 3 | RT | Second function selection/stop-on contact selection 1 | | NET | | | External | | | Pr. 270 = 1 (stop-on-contact 1) |
| | 4 | AU | Terminal 4 input selection | | — | Combined | | — | Combined | | |
| | 5 | JOG | Jog operation selection | | — | | | External | | | |
| | 7 | OH | External thermal relay input | | External | | | | | | |
| | 8 | REX | Fifteen speed selection | | NET | External | | NET | External | | Pr. 59 = 0 (multi-speeds) |
| | 10 | X10 | Inverter operation enable signal | | External | | | | | | |
| | 12 | X12 | PU operation external interlock | | External | | | | | | |
| | 14 | X14 | PID control valid terminal | | NET | External | | NET | External | | |
| | 15 | BRI | Brake opening completion signal | | NET | | | NET | | | |
| 16 | X16 | PU-external operation switch-over | | External | | | | | | | |
| 18 | X18 | V/f switching | | NET | | | External | | | | |

Tab. 6-62: Writing operation and speed commands (1)

| Operation Location Selection | | | Communication operation command source (Pr. 338) | | 0: NET | | | 1: External | | | Remarks |
|------------------------------|----------------------------|---------------------------|--|-----------------------------------|----------|-------------|-------------|-------------|-------------|-------------|---|
| | | | Communication speed command source (Pr.339) | | 0: NET | 1: External | 2: External | 0: NET | 1: External | 2: External | |
| Selective function | Pr. 178 to Pr. 184 setting | 24 | MRS | Output stop | Combined | | | External | | | Pr. 79 ≠ 7 |
| | | | | PU operation interlock | External | | | | | | Pr. 79 = 7 (When X12 signal is not assigned) |
| | | 25 | STOP | Start self-holding selection | — | | | External | | | |
| | | 60 | STF | Forward rotation command | NET | | | External | | | |
| | | 61 | STR | Reverse rotation command | NET | | | External | | | |
| | | 62 | RES | Reset | External | | | | | | |
| | | 65 | X65 | PU-NET operation switchover | External | | | | | | |
| | | 66 | X66 | External-NET operation switchover | External | | | | | | |
| 67 | X67 | Command source switchover | External | | | | | | | | |

Tab. 6-62: Writing operation and speed commands (2)

Explanation of table:

External: Operation is valid only from external terminal signal.

NET: Control only from communication is valid.

Combined: Operation is valid from either of external terminal and communication.

—: Operation is invalid from either of external terminal and communication.

NOTES

The control source of communication is as set in Pr. 550 and Pr. 551.

The Pr. 338 and Pr. 339 settings can be changed while the inverter is running when Pr. 77 = 2. Note that the setting change is reflected after the inverter has stopped. Until the inverter has stopped, communication operation command source and communication speed command source before the setting change are valid.

Switching of command source by external terminal (X67)

In the network operation mode, the command source switching signal (X67) can be used to switch the start command source and speed command source.

Set "67" to any of Pr. 178 to Pr. 184 "Input terminal function selection" to assign the X67 signal to the control terminal.

When the X67 signal is off, the start command source and speed command source are control terminal.

| X67 Signal State | Operation Command Source | Speed Command Source |
|----------------------|--|----------------------|
| No signal assignment | According to Pr. 338 | According to Pr. 339 |
| ON | | |
| OFF | Operation is valid only from external terminal signal. | |

Tab. 6-63: Switching of command source by the signal X67

NOTES

The ON/OFF state of the X67 signal is reflected only during a stop. It is reflected after a stop when the terminal is switched during operation.

When the X67 signal is off, a reset via communication is disabled.

Changing the terminal assignment using Pr. 178 to Pr. 184 "Input terminal function selection" may affect the other functions. Please make setting after confirming the function of each terminal.

6.19 Communication operation and setting

| Purpose | Parameters that must be set | | Refer to Section |
|---|---|--|------------------|
| Communication operation from PU connector | Initial setting of computer link communication (PU connector) | Pr. 117–Pr. 124 | 6.19.2 |
| | Modbus-RTU communication specification | Pr. 117, Pr. 118, Pr. 120, Pr. 122, Pr. 343, Pr. 502 Pr. 549 | 6.19.5 |
| Restrictions on parameter write through communication | Communication E ² PROM write selection | Pr. 342 | 6.19.3 |
| Communication using USB (FR Configurator) | USB communication | Pr. 547, Pr. 548 | 6.19.6 |

6.19.1 PU connector

Using the PU connector, you can perform communication operation from a personal computer etc. When the PU connector is connected with a personal, FA or other computer by a communication cable, a user program can run and monitor the inverter or read and write to parameters.

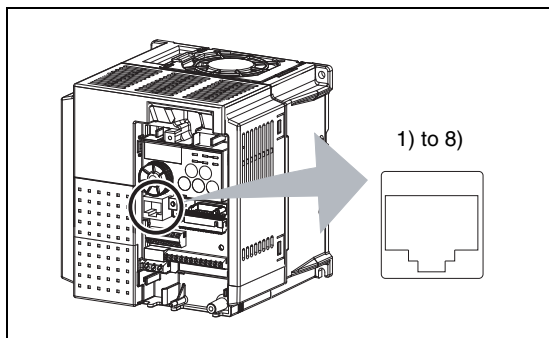

Fig. 6-108:
PU connector pin-outs

I001935E

| Pin Number | Name | Description |
|------------|------|--|
| 1) | SG | Earth (Ground) (connected to terminal 5) |
| 2) | — | Operation panel power supply |
| 3) | RDA | Inverter receive+ |
| 4) | SDB | Inverter send– |
| 5) | SDA | Inverter send+ |
| 6) | RDB | Inverter receive– |
| 7) | SG | Earth (Ground) (connected to terminal 5) |
| 8) | — | Operation panel power supply |

Tab. 6-64: PU connector (terminal description)

NOTES

Pins No. 2) and 8) provide power to the operation panel or parameter unit. Do not use these pins for RS-485 communication.

Do not connect the PU connector to the computer's LAN board, FAX modem socket or telephone modular connector. The product could be damaged due to differences in electrical specifications.

PU connector communication system configuration and wiring

- Connecting the PU to the inverter

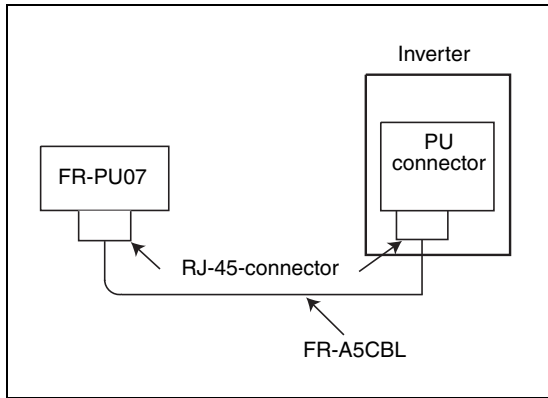

Fig. 6-109:
Connecting the PU to the PU connector

I001829E

- Connecting a computer to a single inverter

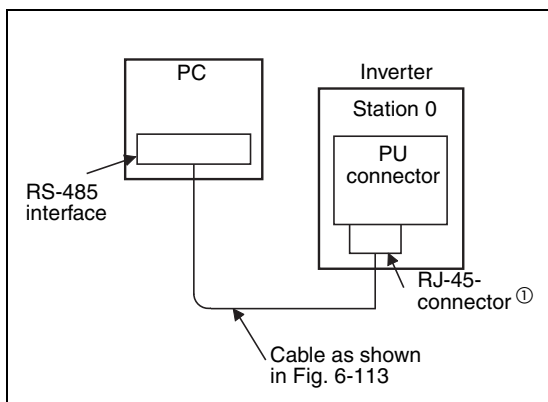

Fig. 6-110:
Connecting the RS-485 interface of a PC to the PU connector

I001211E

- ① Pins No. 2) and 8) provide power to the operation panel or parameter unit. Do not use these pins for RS-485 communication.

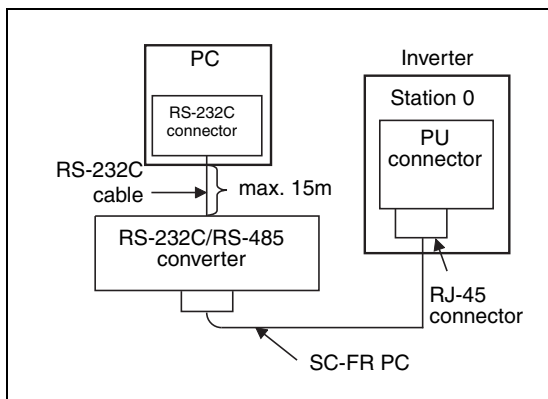

Fig. 6-111:
Connecting the RS-232C interface of a PC to the PU connector

I001212E

● Combination of computer and multiple inverters

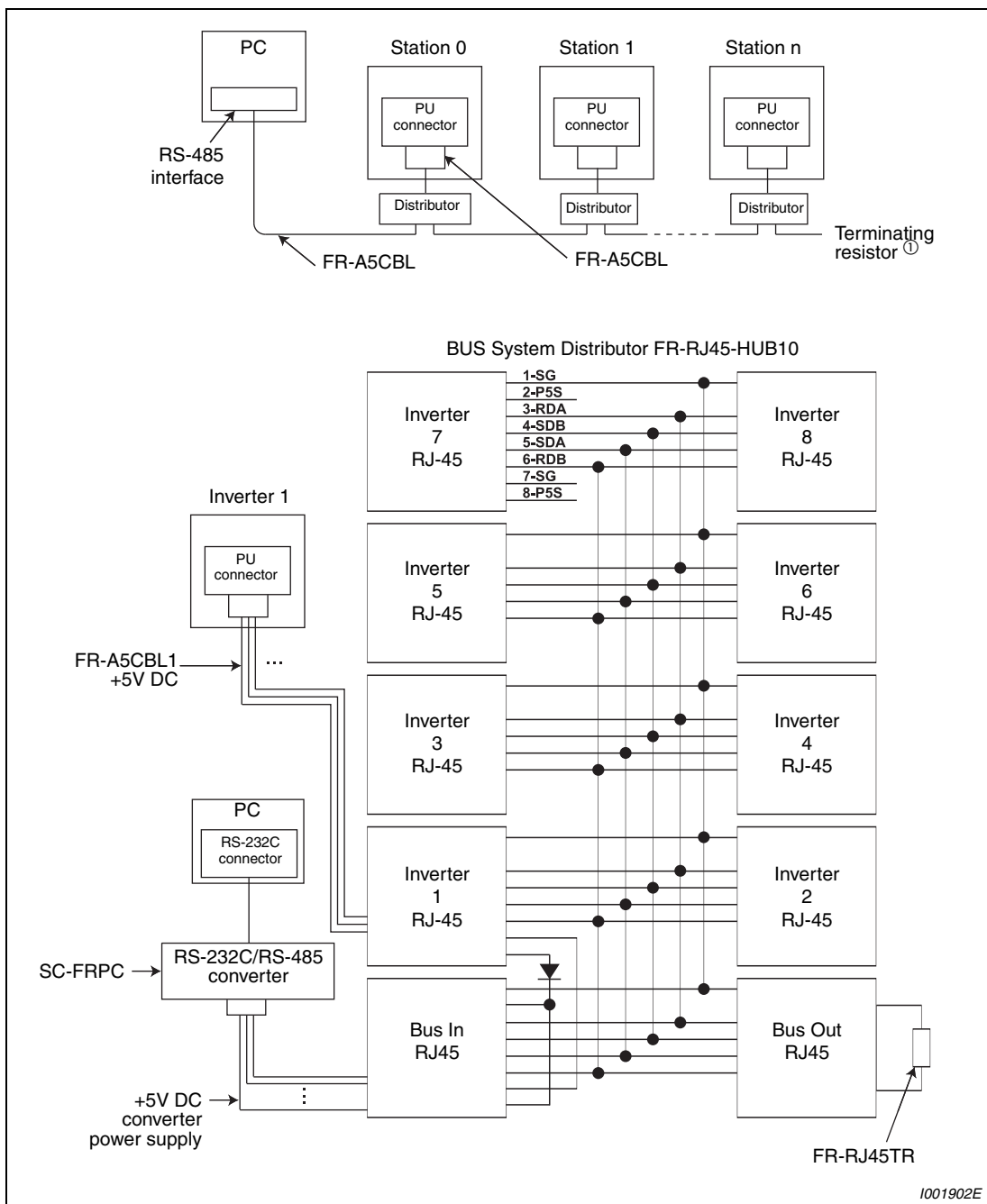

Fig. 6-112: Connection of a computer to several inverters

- ① The inverters may be affected by reflection depending on the transmission speed or transmission distance. If this reflection hinders communication, provide a terminating resistor. If the PU connector is used to make a connection, use a distributor since a terminating resistor cannot be fitted. Connect the terminating resistor to only the inverter remotest from the computer. (Terminating resistor: 100Ω)

Connection with RS-485 computer

- Wiring of one RS-485 computer and one inverter

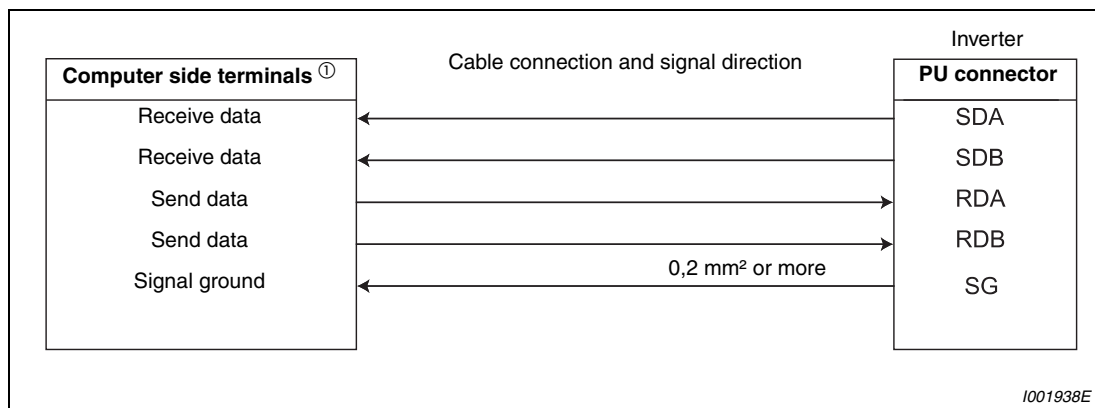

Fig. 6-113: Connection to an inverter

- Wiring of one RS-485 computer and "n" inverters (several inverters)

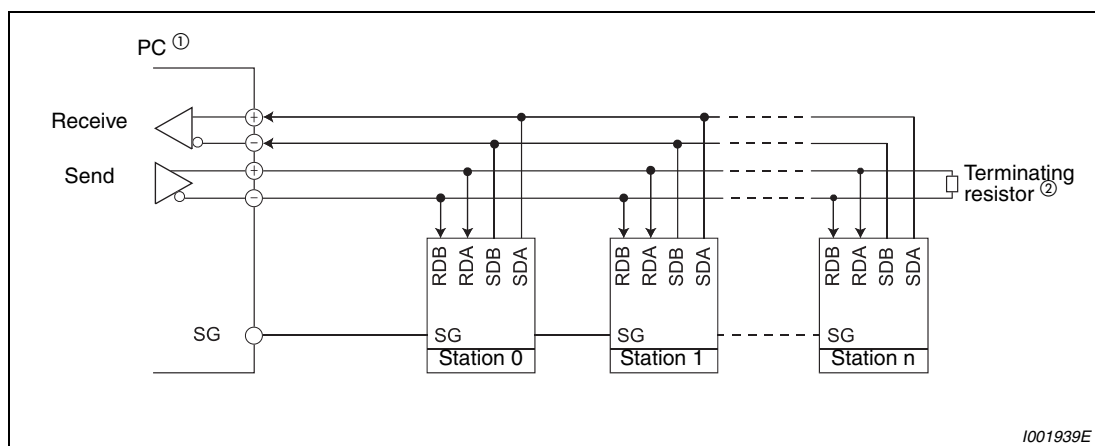

Fig. 6-114: Connection to several inverter

- ① Make connection in accordance with the instruction manual of the computer to be used with. Fully check the terminal numbers of the computer since they vary with the model.
- ② The inverters may be affected by reflection depending on the transmission speed or transmission distance. If this reflection hinders communication, provide a terminating resistor. If the PU connector is used to make a connection, use a distributor since a terminating resistor cannot be fitted. Connect the terminating resistor to only the inverter remotest from the computer. (Terminating resistor: 100Ω)

NOTE

Do not use pins No. 2, 8 of the FR-A5CBL cable. (Refer to page 6-221.)

Two-wire type connection

If the computer is 2-wire type, a connection from the inverter can be changed to 2-wire type by passing wires across reception terminals and transmission terminals of the PU connector pin.

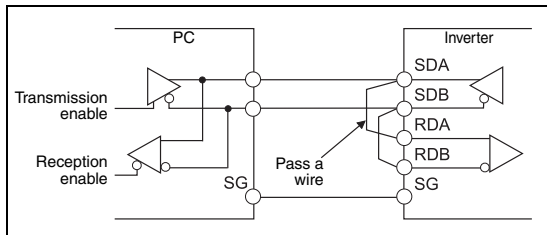

Fig. 6-115:
Two-wire type connection

1001833E

NOTES

A program should be created so that transmission is disabled (receiving state) when the computer is not sending and reception is disabled (sending state) during sending to prevent the computer from receiving its own data.

The passed wiring length should be as short as possible.

6.19.2 Initial settings and specifications of RS-485 communication (Pr. 117 to Pr. 120, Pr. 123, Pr. 124, Pr. 549)

Used to perform required settings for RS-485 communication between the inverter and personal computer. Use PU connector of the inverter for communication.

- You can perform parameter setting, monitoring, etc. using Mitsubishi inverter protocol or Modbus-RTU protocol.
- To make communication between the personal computer and inverter, initialization of the communication specifications must be made to the inverter. Data communication cannot be made if the initial settings are not made or there is any setting error.

PU connector communication related parameter

| Pr. No. | Name | Initial Value | Setting Range | Description | Parameters referred to | Refer to Section |
|---------|---|---------------|-------------------|--|------------------------|------------------|
| 117 | PU communication station number | 0 | 0–31 (0–247) ① | Specify the inverter station number. Set the inverter station numbers when two or more inverters are connected to one personal computer. | — | |
| 118 | PU communication speed | 192 | 48/96/ 192/384 | Set the communication speed. The setting value × 100 equals the communication speed. For example, the communication speed is 19200bps when the setting value is "192". | | |
| 119 | PU communication stop bit length | 1 | | Stop bit length | Data length | |
| | | | 0 | 1bit | 8bit | |
| | | | 1 | 2bit | | |
| | | | 10 | 1bit | 7bit | |
| 11 | 2bit | | | | | |
| 120 | PU communication parity check | 2 | 0 | Without parity check | | |
| | | | 1 | With odd parity check | | |
| | | | 2 | With even parity check | | |
| 123 | PU communication waiting time setting | 9999 | 0–150 ms | Set the waiting time between data transmission to the inverter and response. | | |
| | | | 9999 | Set with communication data. | | |
| 124 | PU communication CR/LF presence/absence selection | 1 | 0 | Without CR/LF | | |
| | | | 1 | With CR | | |
| | | | 2 | With CR/LF | | |
| 549 | Protocol selection | 0 | 0 | Mitsubishi inverter (computer link operation) protocol | | |
| | | | 1 | Modbus-RTU protocol | | |

The above parameters can be set when Pr. 160 "User group read selection" = 0.

- ① When "1" (Modbus-RTU protocol) is set in Pr. 549, the setting range within parenthesis is applied.

NOTE

Always reset the inverter after making the initial settings of the parameters. After you have changed the communication-related parameters, communication cannot be made until the inverter is reset.

Operation selection at communication error occurrence (Pr. 121, Pr. 122, Pr. 502)

| Pr. No. | Name | Initial Value | Setting Range | Description | Parameters referred to | Refer to Section | |
|------------|--|---------------|---------------------|--|--|--------------------------|-----------------------------|
| 121 | Number of PU communication retries | 1 | 0-10 | Number of retries at data receive error occurrence If the number of consecutive errors exceeds the permissible value, the inverter will come to trip (depends on Pr. 502). Valid only Mitsubishi inverter (computer link operation) protocol | 7 Acceleration time 8 Deceleration time 190-192 Output terminal function selection | 6.7.1 6.7.1 6.10.5 | |
| | | | 9999 | If a communication error occurs, the inverter will not come to trip. | | | |
| 122 | PU communication check time interval | 0 | 0 | RS-485 communication can be made. Note that a communication fault (E.PUE) occurs as soon as the inverter is switched to the operation mode with command source. | | | |
| | | | 0.1 _ 999.8 s | Communication check (signal loss detection) time interval If a no-communication state persists for longer than the permissible time, the inverter will come to trip (depends on Pr. 502). | | | |
| | | | 9999 | No communication check (signal loss detection) | | | |
| 502 | Stop mode selection at communication error | 0 | | At fault occurrence | Indication | Fault output | At fault removal |
| | | | 0/3 | Coasts to stop | E.PUE | Output | Stop (E.PUE) |
| | | | 1 | Decelerates to stop | After stop E.PUE | Output after stop | Stop (E.PUE) |
| | | | 2 | Decelerates to stop | After stop E.PUE | Without output | Automatic restart functions |

The above parameters can be set when Pr. 160 "User group read selection" = 0. However, it can be set any time when the communication option is connected. (Refer to section 6.17.4.)

Retry count setting (Pr.121)

Set the permissible number of retries at data receive error occurrence. (Refer to page 6-239 for data receive error for retry.)

When data receive errors occur consecutively and exceed the permissible number of retries set, an inverter trips (E.PUE) and a motor stops (as set in Pr. 502).

When "9999" is set, an inverter fault is not provided even if data receive error occurs but an alarm signal (LF) is output.

For the terminal used for the LF signal output, assign the function by setting "98 (positive logic) or 198 (negative logic)" in any of Pr. 190 to Pr. 192 "Output terminal function selection".

Example ▾

PU connector communication at different settings of parameter 121

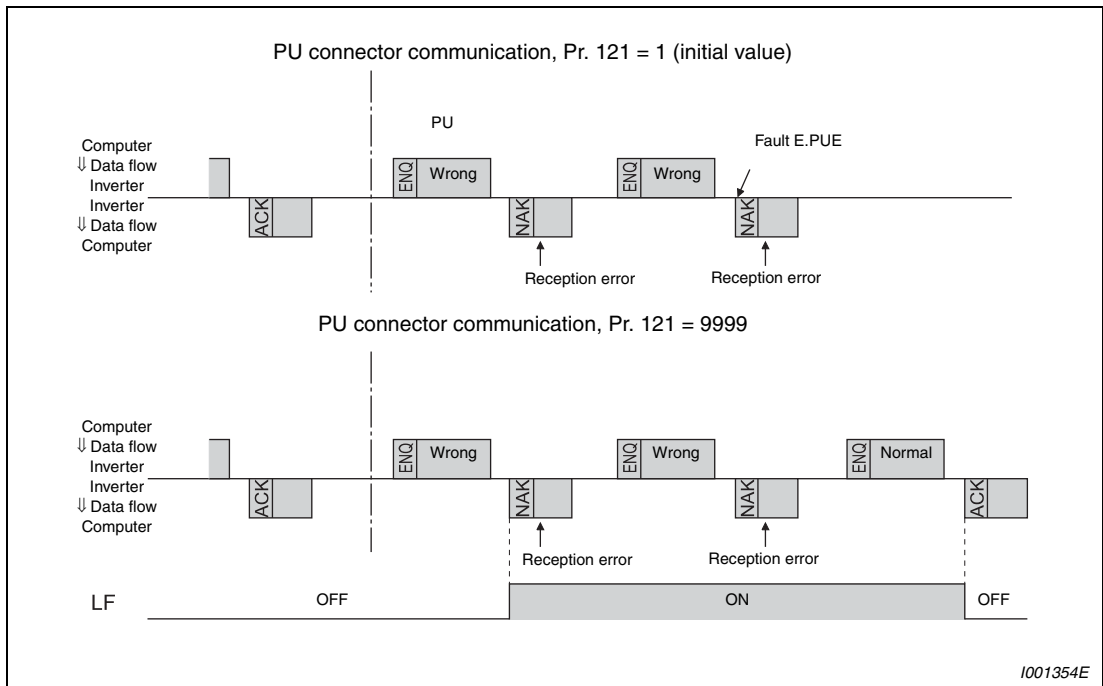

Fig. 6-116: Data transmission error



NOTE

Pr. 121 is valid only when Mitsubishi inverter (computer link operation) protocol is selected. Pr. 121 is not valid when Modbus-RTU communication protocol is selected.

Signal loss detection (Pr. 122)

If a signal loss (communication stop) is detected between the inverter and master as a result of a signal loss detection, a communication fault (E.PUE) occurs and the inverter trips (as set in Pr. 502).

When the setting is "9999", communication check (signal loss detection) is not made.

When the setting value is "0" (initial value), RS-485 communication can be made. However, a communication fault (E.PUE) occurs as soon as the inverter is switched to the operation mode (network operation mode in the initial setting) with the control.

A signal loss detection is made when the setting is any of "0.1s to 999.8s". To make a signal loss detection, it is necessary to send data (refer to Mitsubishi inverter protocol control code (page 6-237), Modbus-RTU communication protocol (page 6-253)) from the computer within the communication check time interval. (The inverter makes communication check (clearing of communication check counter) regardless of the station number setting of the data sent from the master).

Communication check is made from the first communication in the operation mode with control source valid (network operation mode in the initial setting).

Example ▾

PU connector communication, Pr. 122 = 0.1–999.8s

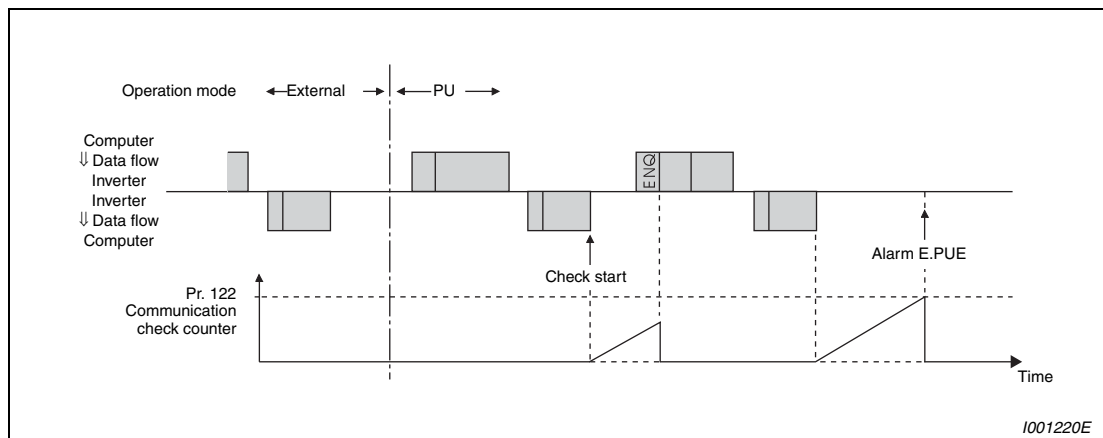

Fig. 6-117: Signal loss detection



NOTES

Always set the communication check time interval before starting operation to prevent hazardous conditions.

Data communication is not started automatically but is made only once when the computer provides a communication request. If communication is disabled during operation due to signal cable breakage etc., the inverter cannot be stopped. When the communication check time interval has elapsed, the inverter will come to an alarm stop (E.PUE). The inverter can be coasted to a stop by switching on its RES signal or by switching power off.

If communication is broken due to signal cable breakage, computer fault etc., the inverter does not detect such a fault. This should be fully noted.

Stop operation selection at occurrence of communication fault (Pr. 502)

Stop operation when retry count excess (Mitsubishi inverter protocol only) or signal loss detection error occurs can be selected.

| Pr. 502 | Operation | Indication | Fault output |
|-------------------|-------------------------|-----------------------|---------------------|
| 0 (initial value) | Coasts to stop. | E. PUE lit | Provided |
| 1 | Decelerates to stop | E. PUE lit after stop | Provided after stop |
| 2 | | | Not provided |
| 3 | Same as the setting "0" | | |

Tab. 6-65: Operation at fault occurrence

| Pr. 502 | Operation | Indication | Fault output |
|-------------------|-----------------------------|----------------|---------------|
| 0 (initial value) | Kept stopped | E.PUE | Kept provided |
| 1 | | | |
| 2 | Automatic restart functions | Normal display | Not provided |
| 3 | Same as the setting "0" | | |

Tab. 6-66: Operation at fault removal

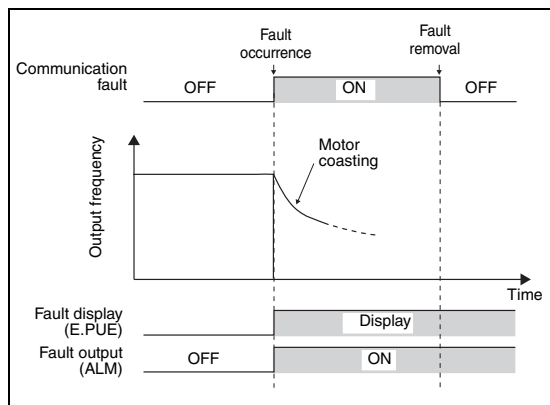

Fig. 6-118: Operation when Pr. 502 setting is "0 (initial value) or 3"

1001834E

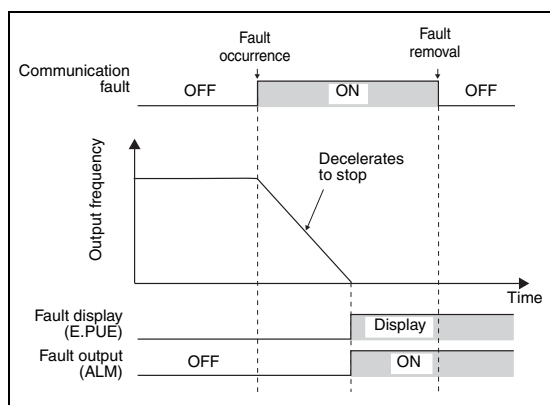

Fig. 6-119: Operation when Pr. 502 setting is "1"

1001835E

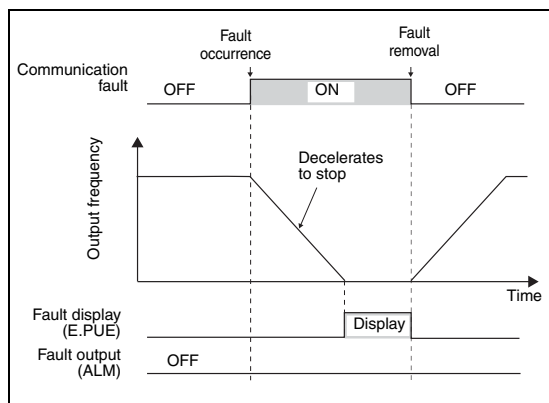

Fig. 6-120:
Operation when Pr. 502 setting is "2"

1001836E

NOTES

The fault output indicates fault output signal (ALM signal) or alarm bit output.

When the setting was made to provide a fault output, the fault description is stored into the faults history. (The fault description is written to the faults history when a fault output is provided.) When no fault output is provided, the fault definition overwrites the fault indication of the faults history temporarily, but is not stored. After the fault is removed, the fault indication returns to the ordinary monitor, and the faults history returns to the preceding fault indication.

When the Pr. 502 setting is "1 or 2", the deceleration time is the ordinary deceleration time setting (e.g. Pr. 8, Pr. 44, Pr. 45). In addition, acceleration time for restart is the normal acceleration time (e.g. Pr. 7, Pr. 44).

When "2" is set in Pr. 502, run command/speed command at restarting follows the command before an fault occurrence.

When "2" is set in Pr. 502 at occurrence of a communication error and the error is removed during deceleration, the inverter accelerates again at that point.

6.19.3 Communication E²PROM write selection (Pr. 342)

When parameter write is performed from the inverter PU connector, USB communication, and communication option, parameters storage device can be changed from E²PROM + RAM to RAM only. Set when a frequent parameter change is necessary.

When changing the parameter values frequently, set "1" in Pr. 342 to write them to the RAM only. The life of the E²PROM will be shorter if parameter write is performed frequently with the setting unchanged from "0 (initial value)" (E²PROM write).

| Pr. No. | Name | Initial Value | Setting Range | Description | Parameters referred to | Refer to Section |
|------------|---|---------------|---------------|---|------------------------|------------------|
| 342 | Communication E ² PROM write selection | 0 | 0 | Parameter values written by communication are written to the E ² PROM and RAM. | — | |
| | | | 1 | Parameter values written by communication are written to the RAM. | | |

The above parameter can be set when Pr. 160 "User group read selection" = 0. However, the parameter can be set whenever the communication option is connected. (Refer to section 6.17.4).

NOTE

When "1" (write to RAM only) is set in Pr. 342, powering off the inverter will erase the changed parameter values. Therefore, the parameter values available when power is switched on again are the values stored in E²PROM previously.

6.19.4 Mitsubishi inverter protocol (computer link communication)

You can perform parameter setting, monitor, etc. from the PU connector of the inverter using the Mitsubishi inverter protocol (computer link communication).

Communication specifications

| Item | | Description | Related Parameters |
|-------------------------------|------------------|---|--------------------|
| Communication protocol | | Mitsubishi protocol (computer link) | Pr. 549 |
| Conforming standard | | EIA-485 (RS-485) | — |
| Number of inverters connected | | 1 : N (maximum 32 units), setting is 0 to 31 stations | Pr. 117 |
| Communication speed | PU connector | Selected from among 4800/9600/19200 and 38400bps | Pr. 118 |
| Control protocol | | Asynchronous system | — |
| Communication method | | Half-duplex system | — |
| Communication specifications | Character system | ASCII (7 bits or 8 bits can be selected) | Pr. 119 |
| | Start bit | 1 bit | — |
| | Stop bit length | 1 bit or 2 bits can be selected | Pr. 119 |
| | Parity check | Check (even, odd) or no check can be selected | Pr. 120 |
| | Error check | Sum code check | — |
| Terminator | | CR/LF (presence or absence can be selected) | Pr. 124 |
| Waiting time setting | | Selectable between presence and absence | Pr. 123 |

Tab. 6-67: Communication specifications

Communication procedure

Data communication between the computer and inverter is made in the following procedure:

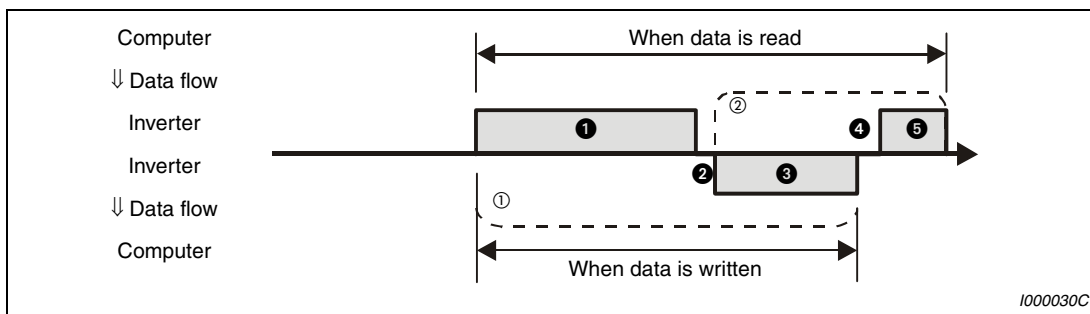

Fig. 6-121: Schematic diagram of data exchange

- ① If a data error is detected and a retry must be made, execute retry operation with the user program. The inverter comes to an alarm stop if the number of consecutive retries exceeds the parameter setting.
- ② On receipt of a data error occurrence, the inverter returns "reply data ③" to the computer again. The inverter comes to an alarm stop if the number of consecutive data errors reaches or exceeds the parameter setting.

Communication operation presence/absence and data format types

Data communication between the computer and inverter is made in ASCII code (hexadecimal code). Data is automatically converted to ASCII format when it is exchanged between an external computer and the frequency inverter. In the following table the different data formats are referred to with the letters A–F. The corresponding formats are explained in the next section.

| No. | Operation | Run Command | Running Frequency | Parameter Write | Inverter Reset | Monitor | Parameter Read | |
|-----|--|---|----------------------|----------------------|----------------|----------------------------|----------------------|------------|
| ① | Communication request is sent to the inverter in accordance with the user program in the computer. | A1 | A A2 ^③ | A A2 ^③ | A | B | B | |
| ② | The inverter will not send data unless requested. | Present | Present | Present | Absent | Present | Present | |
| ③ | Reply data from the inverter (Data ①) is checked for error) | No error ^① (Request accepted) | C | C | C ^② | E E1 E2 ^③ | E E2 ^③ | |
| | | With error (Request rejected) | D | D | D | D ^② | D | D |
| ④ | Computer processing delay time | 10ms or more | | | | | | |
| ⑤ | Answer from computer in response to reply data ③ (Data ③) is checked for error) | No error ^① (No inverter processing) | Absent | Absent | Absent | Absent | Absent (C) | Absent (C) |
| | | With error (Inverter reoutputs ③) | Absent | Absent | Absent | Absent | F | F |

Tab. 6-68: Communication and data format

- ① In the communication request data from the computer to the inverter, 10ms or more is also required after "no data error (ACK)". (Refer to page 6-239.)
- ② The inverter response to the inverter reset request can be selected. (Refer to page 6-243, Tab. 6-73.)
- ③ When any of "0.01 to 9998" is set in Pr. 37 and "01" in instruction code HFF sets data format to "A2" or "E2". In addition, data format is always A2 and E2 for read or write of Pr. 37.

● Data writing format

Communication request data from the computer to the inverter

| Format | Number of Characters | | | | | | | | | | | | | | |
|--------|----------------------|--------------------------------------|---|------------------|---|---------------------------|------|---|-----------|----|-----------|-----------|----|----|----|
| | 1 | 2 | 3 | 4 | 5 | 6 | 7 | 8 | 9 | 10 | 11 | 12 | 13 | 14 | 15 |
| A | ENQ ^① | Inverter station number ^② | | Instruction code | | Waiting time ^③ | Data | | | | Sum check | | ④ | | |
| A1 | ENQ ^① | Inverter station number ^② | | Instruction code | | Waiting time ^③ | Data | | Sum check | | ④ | | | | |
| A2 | ENQ ^① | Inverter station number ^② | | Instruction code | | Waiting time ^③ | Data | | | | | Sum check | | ④ | |

Reply data from the inverter to the computer (no data error detected)

| Format | Number of Characters | | | |
|--------|----------------------|--------------------------------------|---|---|
| | 1 | 2 | 3 | 4 |
| C | ACK ^① | Inverter station number ^② | | ④ |

Reply data from the inverter to the computer (data error detected)

| Format | Number of Characters | | | | |
|--------|----------------------|--------------------------------------|---|------------|---|
| | 1 | 2 | 3 | 4 | 5 |
| D | NAK ^① | Inverter station number ^② | | Error code | ④ |

- ① Indicate a control code (Refer to Tab. 6-69.)
- ② Specify the inverter station numbers between H00 and H1F (stations 0 to 31) in hexadecimal.
- ③ When Pr. 123, Pr. 337 "Waiting time setting" ≠ 9999, create the communication request data without "waiting time" in the data format. (The number of characters decreases by 1.)
- ④ CR, LF code
When data is transmitted from the computer to the inverter, codes CR (carriage return) and LF (line feed) are automatically set at the end of a data group on some computers. In this case, setting must also be made on the inverter according to the computer. Whether the CR and LF codes will be present or absent can be selected using Pr. 124 "CR, LF selection".

● Data reading format

Communication request data from the computer to the inverter

| Format | Number of Characters | | | | | | | | |
|--------|----------------------|--------------------------------------|---|------------------|---|-----------------------------------|-----------|---|---|
| | 1 | 2 | 3 | 4 | 5 | 6 | 7 | 8 | 9 |
| B | ENQ ^① | Inverter station number ^② | | Instruction code | | Wait- ing time ^③ | Sum check | | ④ |

Reply data from the inverter to the computer (no data error detected)

| Format | Number of Characters | | | | | | | | | | | | | |
|--------|----------------------|--------------------------------------|---|-----------|---|------------------|-----------|------------------|-----------|------------------|-----------|----|----|--|
| | 1 | 2 | 3 | 4 | 5 | 6 | 7 | 8 | 9 | 10 | 11 | 12 | 13 | |
| E | STX ^① | Inverter station number ^② | | Read data | | | | ETX ^① | Sum check | | ④ | | | |
| E1 | STX ^① | Inverter station number ^② | | Read data | | ETX ^① | Sum check | | ④ | | | | | |
| E2 | STX ^① | Inverter station number ^② | | Read data | | | | | | ETX ^① | Sum check | | ④ | |

Reply data from the inverter to the computer (data error detected)

| Format | Number of Characters | | | | |
|--------|----------------------|--------------------------------------|---|------------|---|
| | 1 | 2 | 3 | 4 | 5 |
| D | NAK ^① | Inverter station number ^② | | Error code | ④ |

Send data from the computer to the inverter during data read

| Format | Number of Characters | | | |
|-------------------------------|----------------------|--------------------------------------|---|---|
| | 1 | 2 | 3 | 4 |
| C (No data error detected) | ACK ^① | Inverter station number ^② | | ④ |
| F (Data error detected) | NAK ^① | Inverter station number ^② | | ④ |

- ① Indicate a control code (Refer to Tab. 6-69.)
- ② Specify the inverter station numbers between H00 and H1F (stations 0 to 31) in hexadecimal.
- ③ When Pr. 123, Pr. 337 "Waiting time setting" ≠ 9999, create the communication request data without "waiting time" in the data format. (The number of characters decreases by 1.)
- ④ CR, LF code
When data is transmitted from the computer to the inverter, codes CR (carriage return) and LF (line feed) are automatically set at the end of a data group on some computers. In this case, setting must also be made on the inverter according to the computer. Whether the CR and LF codes will be present or absent can be selected using Pr. 124 "CR, LF selection".

Data definitions

● Control codes

| Signal Name | ASCII Code | Description |
|-------------|------------|--|
| STX | H02 | Start Of Text (start of data) |
| ETX | H03 | End Of Text (end of data) |
| ENQ | H05 | Enquiry (communication request) |
| ACK | H06 | Acknowledge (no data error detected) |
| LF | H0A | Line Feed |
| CR | H0D | Carriage Return |
| NAK | H15 | Negative Acknowledge (data error detected) |

Tab. 6-69: Control codes

● Inverter station number

Specify the station number of the inverter which communicates with the computer. The inverter station numbers are specified between H00 and H1F (stations 0 to 31) in hexadecimal.

● Instruction code

Specify the processing request, e.g. operation or monitoring, given by the computer to the inverter. Hence, the inverter can be run and monitored in various ways by specifying the instruction code as appropriate. (Refer to the appendix.)

● Data

Indicates the data such as frequency and parameters transferred to and from the inverter. The definitions and ranges of set data are determined in accordance with the instruction codes. (Refer to the appendix.)

● Waiting time

Specify the waiting time between the receipt of data at the inverter from the computer and the transmission of reply data. Set the waiting time in accordance with the response time of the computer between 0 and 150ms in 10ms increments (e.g. 1 = 10ms, 2 = 20ms).

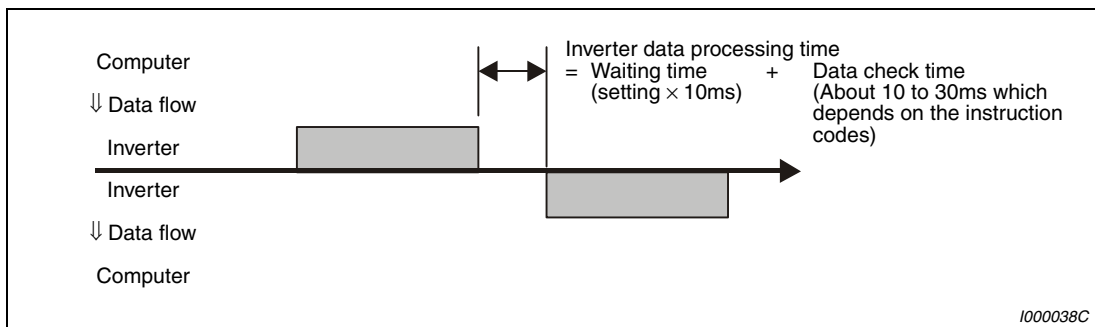

Fig. 6-122: Specifying the waiting time

NOTES

When Pr. 123 "Waiting time setting" ≠ 9999, create the communication request data without "waiting time" in the data format. (The number of characters decreases by 1.)

The data check time changes depending on the instruction code. (Refer to page 6-240).

- Sum check code
The sum check code is 2-digit ASCII (hexadecimal) representing the lower 1 byte (8 bits) of the sum (binary) derived from the checked ASCII data.

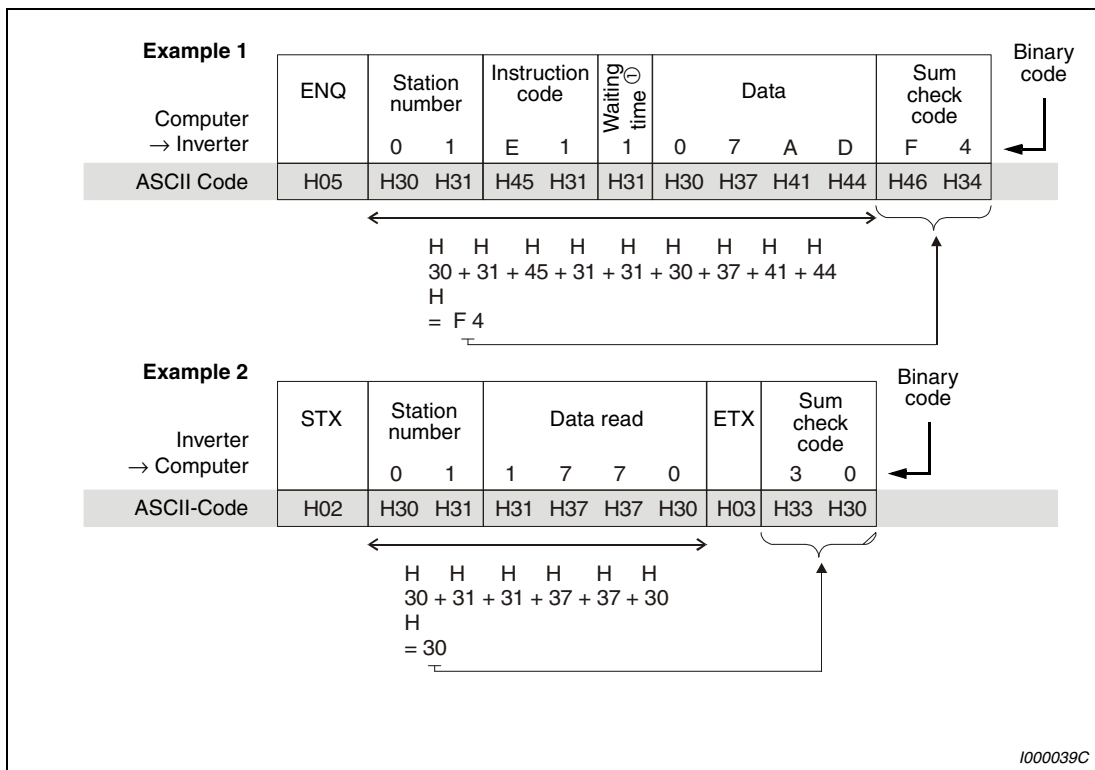

Fig. 6-123: Sum check code (examples)

- ① When Pr. 123 "Waiting time setting" ≠ 9999, create the communication request data without "waiting time" in the data format. (The number of characters decreases by 1.)

- Error code

If any error is found in the data received by the inverter, its definition is sent back to the computer together with the NAK code.

| Error Code | Error Item | Error Definition | Inverter Operation |
|------------|------------------------|---|--|
| H0 | Computer NAK error | The number of errors consecutively detected in communication request data from the computer is greater than allowed number of retries. | Brought to an alarm stop if error occurs continuously more than the allowable number of retries. (E.PUE) |
| H1 | Parity error | The parity check result does not match the specified parity. | |
| H2 | Sum check error | The sum check code in the computer does not match that of the data received by the inverter. | |
| H3 | Protocol error | The data received by the inverter has a grammatical mistake. Alternatively, data receive is not completed within the predetermined time. CR or LF is not as set in the parameter. | |
| H4 | Framing error | The stop bit length differs from the initial setting. | |
| H5 | Overrun error | New data has been sent by the computer before the inverter completes receiving the preceding data. | |
| H6 | — | — | — |
| H7 | Character error | The character received is invalid (other than 0 to 9, A to F, control code). | Does not accept received data but is not brought to alarm stop. |
| H8 | — | — | — |
| H9 | — | — | — |
| HA | Mode error | Parameter write was attempted in other than the computer link operation mode, when operation command source is not selected or during inverter operation. | Does not accept received data but is not brought to alarm stop. |
| HB | Instruction code error | The specified command does not exist. | |
| HC | Data range error | Invalid data has been specified for parameter write, frequency setting, etc. | |
| HD | — | — | — |
| HE | — | — | — |
| HF | — | — | — |

Tab. 6-70: Error codes

● Response time

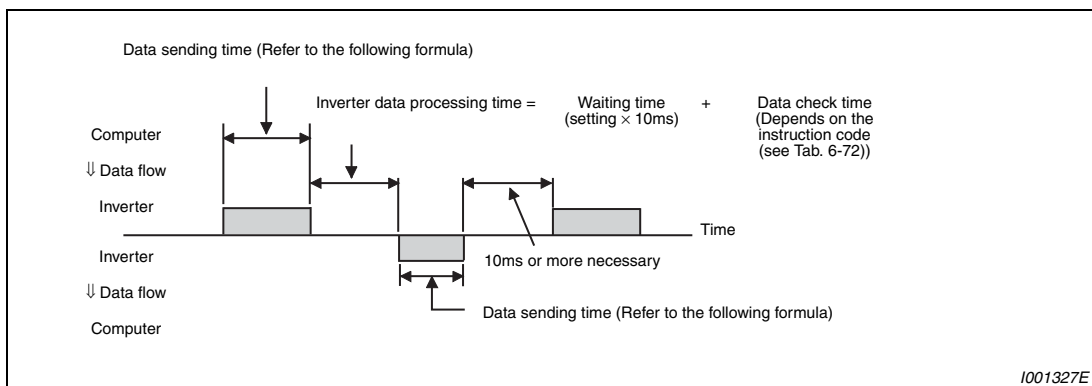

Fig. 6-124: Response time

Formula for data sending time:

$$\text{Data sending time [s]} = \frac{1}{\text{Communication speed (Baudrate)}} \times \text{Number of data characters (refer to page 6-234)} \times \text{Communications specifications (total number of bits)} \text{①}$$

① The communication specifications are listed in the table below:

| Name | | Number of Bits |
|-----------------|-----|----------------|
| Stop bit length | | 1 bit |
| | | 2 bits |
| Data length | | 7 bit |
| | | 8 bits |
| Parity check | Yes | 1 bit |
| | No | 0 bits |

Tab. 6-71: Communication specifications

NOTES

In addition to the above, 1 start bit is necessary.

Minimum number of total bits: 9 bits. Maximum number of total bits: 12 bits.

The data check time related to different functions is shown in the table below:

| Function | Data Check Time |
|---|-----------------|
| Various monitors, run command, frequency setting (RAM) | < 12ms |
| Parameter read/write, frequency setting (E ² PROM) | < 30ms |
| Parameter clear/all clear | < 5s |
| Reset command | — (no answer) |

Tab. 6-72: Data check time

Instructions for the program

When data from the computer has any error, the inverter does not accept that data. Hence, in the user program, always insert a retry program for data error.

All data communication, e.g. run command or monitoring, are started when the computer gives a communication request. The inverter does not return any data without the computer's request. Hence, design the program so that the computer gives a data read request for monitoring, etc. as required.

Program example

To change the operation mode to computer link operation

Programming example of Microsoft® Visual C++® (Ver.6.0)

```
#include <stdio.h>
#include <windows.h>
void main(void){
    HANDLE          hCom;          //Communication handle
    DCB              hDcb;        //Structure for communication setting
    COMMTIMEOUTS    hTim;        //Structure for time out setting

    char            szTx[0x10];    //Send buffer
    char            szRx[0x10];    //Receive buffer
    char            szCommand[0x10]; //Command
    int             nTx,nRx;       //For buffer size storing
    int             nSum;          //For sum code calculation
    BOOL            bRet;
    int             nRet;
    int             i;

    //**** Opens COM1 Port****
    hCom = CreateFile ("COM1", (GENERIC_READ | GENERIC_WRITE), 0, NULL, OPEN_EXISTING, FILE_ATTRIBUTE_NORMAL, NULL);
    if (hCom != NULL) {
        //**** Makes a communication setting of COM1 port****
        GetCommState(hCom,&hDcb); //Retrieves current communication information
        hDcb.DCBlength = sizeof(DCB); //Structure size setting
        hDcb.BaudRate = 19200; //Communication speed=19200bps
        hDcb.ByteSize = 8; //Data length=8bit
        hDcb.Parity = 2; //Even parity
        hDcb.StopBits = 2; //Stop bit=2bit
        bRet = SetCommState(hCom,&hDcb); //Sets the changed communication data
        if (bRet == TRUE) {
            //**** Makes a time out setting of COM1 port****
            GetCommTimeouts(hCom,&hTim); //Obtains the current time out value
            hTim.WriteTotalTimeoutConstant = 1000; //Write time out 1s
            hTim.ReadTotalTimeoutConstant = 1000; //Read time out 1s
            SetCommTimeouts(hCom,&hTim); //Changed time out value setting
            //**** Sets the command to switch the operation mode of the station 1 inverter to the network operation mode ****
            sprintf(szCommand,"01FB10000"); //Send data (NET operation write)
            nTx = strlen(szCommand); //Send data size
            //**** Generates sum code****
            nSum = 0; //Initialization of sum data
            for (i = 0;i < nTx;i++) {
                nSum += szCommand[i]; //Calculates sum code
                nSum &= 0xff; //Masks data
            }

            //**** Generates send data****
            memset(szTx,0,sizeof(szTx)); //Initialization of send buffer
            memset(szRx,0,sizeof(szRx)); //Initialization of receive buffer
            sprintf(szTx,"%5s%02X",szCommand,nSum); //ENQ code+send data+sum code
            nTx = 1 + nTx + 2; //Number of ENQ code+number of send data+number of sum code

            nRet = WriteFile(hCom,szTx,nTx,&nTx,NULL);
            //**** Sending ****
            if(nRet != 0) {
                nRet = ReadFile(hCom,szRx,sizeof(szRx),&nRx,NULL);
                //**** Receiving ****
                if(nRet != 0) {
                    //**** Displays the receive data ****
                    for(i = 0;i < nRx;i++) {
                        printf("%02X ",(BYTE)szRx[i]); //Consol output of receive data
                        //Displays ASCII coder in hexadecimal. Displays 30 when "0"
                    }
                    printf("\n\r");
                }
            }
        }
        CloseHandle(hCom); //Close communication port
    }
}
```

Fig. 6-125:Programming example

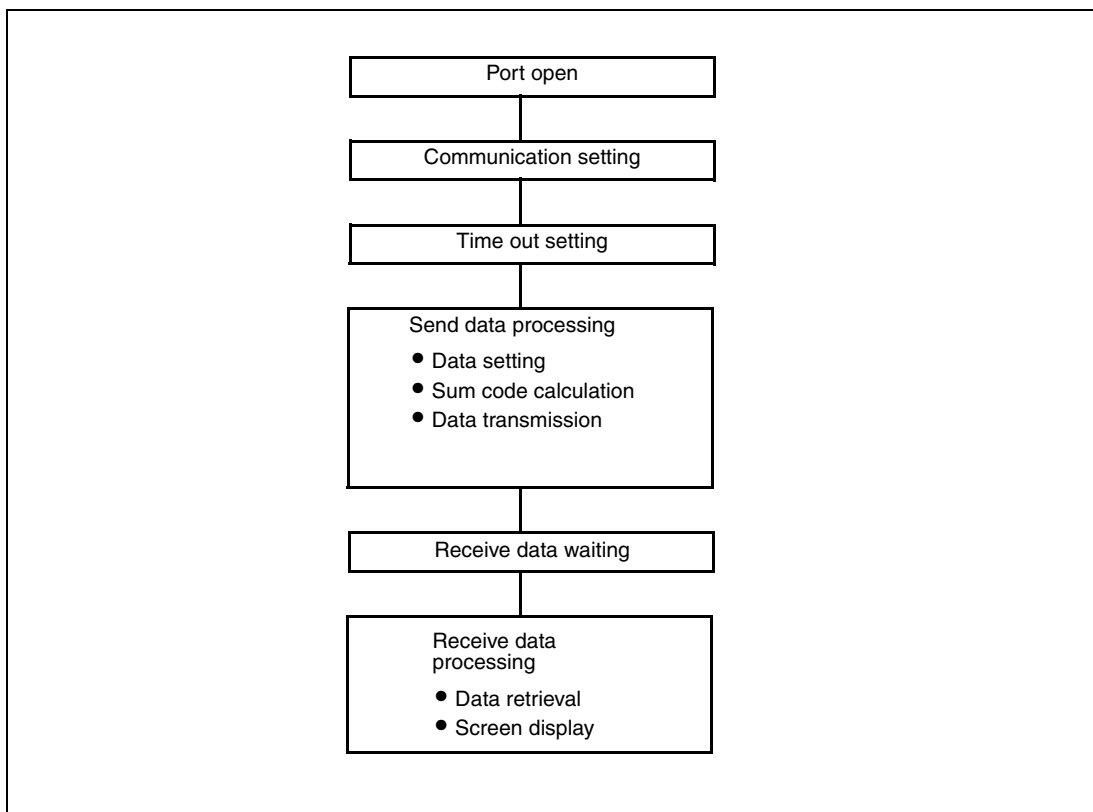

Fig. 6-126: General flowchart

NOTES

Always set the communication check time interval before starting operation to prevent hazardous conditions.

Data communication is not started automatically but is made only once when the computer provides a communication request. If communication is disabled during operation due to signal cable breakage etc., the inverter cannot be stopped. When the communication check time interval has elapsed, the inverter will come to an alarm stop (E.PUE). The inverter can be coasted to a stop by switching on its RES signal or by switching power off.

If communication is broken due to signal cable breakage, computer fault etc., the inverter does not detect such a fault. This should be fully noted.

Setting items and set data

After completion of parameter setting, set the instruction codes and data then start communication from the computer to allow various types of operation control and monitoring.

| No. | Item | Read/write | Instruction Code | Data Description | Number of Data Digits (Format) | | | | | | | | | | | | | | |
|------|---|------------|---|--|---------------------------------|----------------|-----|--|--|-----|---|--|-----|--|--|-----|---|--|---------------|
| 1 | Operation Mode | Read | H7B | H000: Network operation H0001: External operation H0002: PU operation | 4 (B, E/D) | | | | | | | | | | | | | | |
| | | Write | HFB | | 4 (A, C/D) | | | | | | | | | | | | | | |
| 2 | Monitor | Read | H6F | H0000 to HFFFF: Output frequency in 0.01Hz increments Speed increments 1/0.001 (when Pr. 37 = 0.01 to 9998) When "0.01 to 9998" is set in Pr. 37 and "01" in instruction code HFF, the increments change to 0.001 and the data format is E2. When "100" is set in Pr. 52, the monitor value is different depending on whether the inverter is at a stop or running. (Refer to section 6.11.2.) | 4 6 (B, E, E2/D) | | | | | | | | | | | | | | |
| | | Read | H70 | H0000 to HFFFF: Output current (hexadecimal) in 0.01A increments | 4 (B, E/D) | | | | | | | | | | | | | | |
| | | Read | H71 | H0000 to HFFFF: Output voltage (hexadecimal) in 0.1V increments | 4 (B, E/D) | | | | | | | | | | | | | | |
| | | Read | H72 | H0000 to HFFFF: Monitor data selected in instruction code HF3 | 4 (B, E/D) 6 (B, E2/D) | | | | | | | | | | | | | | |
| | | Read | Special monitor selection No. | H01 to H3E: Monitor selection data (Refer to Tab. 6-76 on page 6-247.) | 2 (B, E1/D) | | | | | | | | | | | | | | |
| | | | | Write | HF3 | 2 (A1, C/D) | | | | | | | | | | | | | |
| Read | Fault definition | H74 to H77 | H0000 to HFFFF: <table border="1" style="margin-left: 20px;"> <tr> <td style="text-align: center;">b15</td> <td style="text-align: center;">b8 b7</td> <td style="text-align: center;">b0</td> </tr> <tr> <td>H74</td> <td>Second fault in past Latest alarm</td> <td></td> </tr> <tr> <td>H75</td> <td>Fourth fault in past Third fault in past</td> <td></td> </tr> <tr> <td>H76</td> <td>Sixth fault in past Fifth fault in past</td> <td></td> </tr> <tr> <td>H77</td> <td>Eighth fault in past Seventh fault in past</td> <td></td> </tr> </table> (Refer to Tab. 6-77 on page 6-248.) | b15 | b8 b7 | b0 | H74 | Second fault in past Latest alarm | | H75 | Fourth fault in past Third fault in past | | H76 | Sixth fault in past Fifth fault in past | | H77 | Eighth fault in past Seventh fault in past | | 4 (B, E/D) |
| b15 | b8 b7 | b0 | | | | | | | | | | | | | | | | | |
| H74 | Second fault in past Latest alarm | | | | | | | | | | | | | | | | | | |
| H75 | Fourth fault in past Third fault in past | | | | | | | | | | | | | | | | | | |
| H76 | Sixth fault in past Fifth fault in past | | | | | | | | | | | | | | | | | | |
| H77 | Eighth fault in past Seventh fault in past | | | | | | | | | | | | | | | | | | |
| 3 | Run command (extended) | Write | HF9 | You can set the control input commands such as the forward rotation signal (STF) and reverse rotation signal (STR). (Refer to page 6-249 for details.) | 4 (A, C/D) | | | | | | | | | | | | | | |
| | Run command | Write | HFA | | 2 (A1, C/D) | | | | | | | | | | | | | | |
| 4 | Inverter status monitor (extended) | Read | H79 | You can monitor the states of the output signals such as forward rotation, reverse rotation and inverter running (RUN). (Refer to page 6-249 for details.) | 4 (B, E/D) | | | | | | | | | | | | | | |
| | Inverter status monitor | Read | H7A | | 2 (B, E1/D) | | | | | | | | | | | | | | |

Tab. 6-73: Setting of the instruction codes and data (1)

| No. | Item | Read/write | Instruction Code | Data Description | Number of Data Digits (Format) | | | | | | | | | | | | | |
|---------------------|--|-------------------------|------------------|--|---------------------------------|------|-------------------------|-----------------|-------|---|-------|----------------|---------------------|-------|---|-------|----------------|---------------|
| 5 | Set frequency (RAM) | Read | H6D | Read set frequency/speed from RAM or E ² PROM. H0000 to HFFFF: Set frequency in 0.01Hz increments Speed increments 1/0.001 (when Pr. 37 = 0.01 to 9998) When "0.01 to 9998" is set in Pr. 37 and "01" in instruction code HFF, the increments change to 0.001 and the data format is E2. | 4 (B, E/D) 6 (B, E2/D) | | | | | | | | | | | | | |
| | Set frequency (E ² PROM) | | H6E | | | | | | | | | | | | | | | |
| | Set frequency (RAM) | Write | HED | Write set frequency/speed to RAM or E ² PROM. H0000 to H9C40 (0 to 400.00Hz): Frequency increments 0.01Hz Speed increments 1/0.001 (when Pr. 37 = 0.01 to 9998) When "0.01 to 9998" is set in Pr. 37 and "01" in instruction code HFF, the increments change to 0.001 and the data format is A2. To change the set frequency consecutively, write data to the inverter RAM. (instruction code: HED) | 4 (A, C/D) 6 (A2, C/D) | | | | | | | | | | | | | |
| | Set frequency (RAM, E ² PROM) | | HEE | | | | | | | | | | | | | | | |
| 6 | Inverter reset | Write | HFD | H9696: Resets the inverter. As the inverter is reset at start of communication by the computer, the inverter cannot send reply data back to the computer. | 4 (A, C/D) | | | | | | | | | | | | | |
| | | | | H9966: Resets the inverter. When data is sent normally, ACK is returned to the computer and then the inverter is reset. | 4 (A, D) | | | | | | | | | | | | | |
| 7 | Alarm definition all clear | Write | HF4 | H9696: Alarm history batch clear | 4 (A, C/D) | | | | | | | | | | | | | |
| 8 | All parameter clear | Write | HFC | <p>All parameters return to the initial values. Whether to clear communication parameters or not can be selected according to data. (✓: Clear, —: Not clear) Refer to Tab. 6-1 for parameter clear, all clear, and communication parameters.</p> <table border="1"> <thead> <tr> <th>Clear Type</th> <th>Data</th> <th>Communication-parameter</th> </tr> </thead> <tbody> <tr> <td rowspan="2">Parameter clear</td> <td>H9696</td> <td>✓</td> </tr> <tr> <td>H5A5A</td> <td>—^①</td> </tr> <tr> <td rowspan="2">All parameter clear</td> <td>H9966</td> <td>✓</td> </tr> <tr> <td>H55AA</td> <td>—^①</td> </tr> </tbody> </table> <p>①Note that when using a three-phase power input specification model, Pr. 345 and Pr. 346 are set back to initial values. When all parameter clear is executed for H9696 or H9966, communication-related parameter settings also return to the initial values. When resuming operation, set these parameters again. Executing clear will clear the instruction code HEC, HF3, and HFF settings.</p> | Clear Type | Data | Communication-parameter | Parameter clear | H9696 | ✓ | H5A5A | — ^① | All parameter clear | H9966 | ✓ | H55AA | — ^① | 4 (A, C/D) |
| Clear Type | Data | Communication-parameter | | | | | | | | | | | | | | | | |
| Parameter clear | H9696 | ✓ | | | | | | | | | | | | | | | | |
| | H5A5A | — ^① | | | | | | | | | | | | | | | | |
| All parameter clear | H9966 | ✓ | | | | | | | | | | | | | | | | |
| | H55AA | — ^① | | | | | | | | | | | | | | | | |

Tab. 6-73: Setting of the instruction codes and data (2)

| No. | Item | Read/write | Instruction Code | Data Description | Number of Data Digits (Format) |
|-----|---|------------|------------------|---|---------------------------------|
| 9 | Parameters | Read | H00 to H63 | Refer to the instruction code of the parameter list (appendix) and write and/or read parameter values as required. When setting Pr. 100 and later, link parameter extended setting must be set. Data format of Pr. 37 read and write is E2 and A2. | 4 (B, E/D) 6 (B, E2/D) |
| 10 | | Write | H80 to HE3 | | 4 (A, C/D) 6 (A2, C/D) |
| 11 | Link parameter extended setting | Read | H7F | Parameter description is changed according to the H00 to H09 setting. For details of the settings, refer to the instruction code of the parameter list (appendix). | 2 (B, E1/D) |
| | | Write | HFF | | 2 (A1, C/D) |
| 12 | Second parameter changing (instruction code HFF = 1, 9) | Read | H6C | Setting calibration parameter ^① H00: Frequency ^② H01: Parameter-set analog value H02: Analog value input from terminal ^① Refer to the list of calibration parameters on page 6-246. ^② The gain frequency can also be written using Pr. 125 (instruction code: H99) or Pr. 126 (instruction code: H9A). | 2 (B, E1/D) |
| | | Write | HEC | | 2 (A1, C/D) |

Tab. 6-73: Setting of the instruction codes and data (3)

NOTES

Refer to page 6-234 for data formats A, A1, A2, B, C, D, E, E1 and E2.

Set 65520 (HFFF0) as a parameter value "8888" and 65535 (HFFFF) as "9999".

For the instruction codes HFF, HEC and HF3, their values are held once written but cleared to zero when an inverter reset or all clear is performed.

Example ▾

When reading the C3 (Pr. 902) and C6 (Pr. 904) settings from the inverter of station No. 0.

| | Computer Send Data | Inverter Send Data | Description |
|---|--------------------|--------------------|---|
| ① | ENQ 00 FF 0 01 82 | ACK 00 | Set "H01" to the extended link parameter. |
| ② | ENQ 00 EC 0 01 7E | ACK 00 | Set "H01" to second parameter changing. |
| ③ | ENQ 00 5E 0 0F | STX 00 0000 ETX 25 | C3 (Pr. 902) is read. 0% is read. |
| ④ | ENQ 00 60 0 FB | STX 00 0000 ETX 25 | C6 (Pr. 904) is read. 0% is read. |

Tab. 6-74: Example for data transmission

To read/write C3 (Pr. 902) and C6 (Pr. 904) after inverter reset or parameter clear, execute from step ① again.



● List of calibration parameters

| Pr. | Name | Instruction Code | | | Pr. | Name | Instruction Code | | |
|-----------|---|------------------|-------|----------|-----------|---|------------------|-------|----------|
| | | Read | Write | Extended | | | Read | Write | Extended |
| C2 (902) | Terminal 2 frequency setting bias frequency | 5E | DE | 1 | C5 (905) | Terminal 4 frequency setting bias frequency | 60 | E0 | 1 |
| C3 (902) | Terminal 2 frequency setting bias | 5E | DE | 1 | C6 (904) | Terminal 4 frequency setting bias | 60 | E0 | 1 |
| 125 (903) | Terminal 2 frequency setting gain frequency | 5F | DF | 1 | 126 (905) | Terminal 4 frequency setting gain frequency | 61 | E1 | 1 |
| C4 (903) | Terminal 2 frequency setting gain | 5F | DF | 1 | C7 (905) | Terminal 4 frequency setting gain | 61 | E1 | 1 |

Tab. 6-75: Calibration parameters

- Special monitor selection numbers.
Refer to section 6.11.2 for details of the monitor description.

| Data | Description | Unit | Data | Description | Unit |
|------|---|-----------------|------|----------------------------------|------|
| H01 | Output frequency/speed ① | 0.01Hz 0.001 | H14 | Cumulative energization time | 1h |
| H02 | Output current | 0.01A | H17 | Actual operation time | 1h |
| H03 | Output voltage | 0.1V | H18 | Motor load factor | 0.1% |
| H05 | Frequency setting/speed setting ① | 0.01Hz 0.001 | H19 | Cumulative power | 1kWh |
| H07 | Motor torque | 0.1% | H34 | PID set point | 0.1% |
| H08 | Converter output voltage | 0.1V | H35 | PID measured value | 0.1% |
| H09 | Regenerative brake duty | 0.1% | H36 | PID deviation | 0.1% |
| H0A | Electronic thermal relay function load factor | 0.1% | H3A | Option input terminal status 1 ④ | — |
| H0B | Output current peak value | 0.01A | H3B | Option input terminal status 2 ⑤ | — |
| H0C | Converter output voltage peak value | 0.1V | H3C | Option output terminal status ⑥ | — |
| H0E | Output power | 0.01kW | H3D | Motor thermal load factor | 0.1% |
| H0F | Input terminal status ② | — | H3E | Inverter thermal load factor | 0.1% |
| H10 | Output terminal status ③ | — | — | — | — |

Tab. 6-76: Special monitor selection numbers

① When "0.01 to 9998" is set in Pr. 37 and "01" in instruction code HFF, the data format is 6 digits (E2).

② Input terminal monitor details

b15

b0

| | | | | | | | | | | | | | | | |
|---|---|---|---|---|-----|---|-----|---|----|----|----|---|---|-----|-----|
| — | — | — | — | — | RES | — | MRS | — | RH | RM | RL | — | — | STR | STF |
|---|---|---|---|---|-----|---|-----|---|----|----|----|---|---|-----|-----|

③ Output terminal monitor details

b15

b0

| | | | | | | | | | | | | | | | |
|---|---|---|---|---|---|---|---|---|---|-----|----|---|---|---|-----|
| — | — | — | — | — | — | — | — | — | — | ABC | FU | — | — | — | RUN |
|---|---|---|---|---|---|---|---|---|---|-----|----|---|---|---|-----|

④ Details of option input terminal monitor 1 (input terminal status of FR-A7AX E kit)
(All terminals are off when an option is not fitted.)

b15

b0

| | | | | | | | | | | | | | | | |
|-----|-----|-----|-----|-----|-----|----|----|----|----|----|----|----|----|----|----|
| X15 | X14 | X13 | X12 | X11 | X10 | X9 | X8 | X7 | X6 | X5 | X4 | X3 | X2 | X1 | X0 |
|-----|-----|-----|-----|-----|-----|----|----|----|----|----|----|----|----|----|----|

⑤ Details of option input terminal monitor 2 (input terminal status of FR-A7AX E kit)
(All terminals are off when an option is not fitted.)

b15

b0

| | | | | | | | | | | | | | | | |
|---|---|---|---|---|---|---|---|---|---|---|---|---|---|---|----|
| — | — | — | — | — | — | — | — | — | — | — | — | — | — | — | DY |
|---|---|---|---|---|---|---|---|---|---|---|---|---|---|---|----|

⑥ Details of option output terminal monitor (output terminal status of FR-A7AX E kit/A7AR E kit)
(All terminals are off when an option is not fitted.)

b15

b0

| | | | | | | | | | | | | | | | |
|---|---|---|---|---|---|-----|-----|-----|----|----|----|----|----|----|----|
| — | — | — | — | — | — | RA3 | RA2 | RA1 | Y6 | Y5 | Y4 | Y3 | Y2 | Y1 | Y0 |
|---|---|---|---|---|---|-----|-----|-----|----|----|----|----|----|----|----|

● Fault data

Refer to section 7.1 for details of alarm description.

| Data | Description | Data | Description | Data | Description |
|------|------------------|------|-------------|------|-------------|
| H00 | No fault present | H70 | E.BE | HC8 | E.USB |
| H10 | E.OC1 | H80 | E.GF | HD8 | E.MB4 |
| H11 | E.OC2 | H81 | E.LF | HD9 | E.MB5 |
| H12 | E.OC3 | H90 | E.OHT | HDA | E.MB6 |
| H20 | E.OV1 | HA1 | E.OP1 | HDB | E.MB7 |
| H21 | E.OV2 | HB0 | E.PE | HF1 | E.1 |
| H22 | E.OV3 | HB1 | E.PUE | HF5 | E.5 |
| H30 | E.THT | HB2 | E.RET | HF6 | E.6 |
| H31 | E.THM | HB3 | E.PE2 | HF7 | E.7 |
| H40 | E.FIN | HC0 | E.CPU | HFD | E.13 |
| H52 | E.ILF | HC5 | E.IOH | | |
| H60 | E.OLT | HC7 | E.AIE | | |

Tab. 6-77: Fault data

Example ▾

Fault description display example (instruction code: H74)

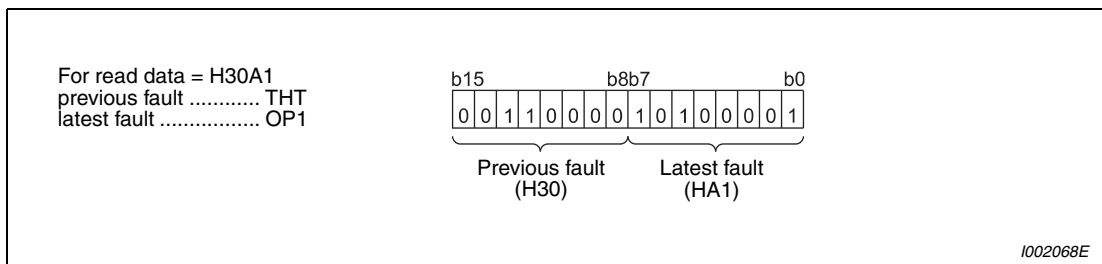

Fig. 6-127: Fault example



● Run command

| Item | Instruction Code | Bits | Description | Example |
|------------------------|------------------|------|---|---|
| Run command | HFA | 8 | b0: AU (current input selection) ③ b1: Forward rotation start b2: Reverse rotation start b3: RL (low speed) ① ③ b4: RM (middle speed) ① ③ b5: RH (high speed) ① ③ b6: RT (second function selection) ③ b7: MRS (output stop) ① ③ | Example 1: H02 (Forward rotation) b7 b0 0 0 0 0 0 0 1 0 Example 2: H00 (Stop) b7 b0 0 0 0 0 0 0 0 0 |
| Run command (extended) | HF9 | 16 | b0: AU (current input selection) ③ b1: Forward rotation start b2: Reverse rotation start b3: RL (low speed) ① ③ b4: RM (middle speed) ① ③ b5: RH (high speed) ① ③ b6: RT (second function selection) ③ b7: MRS (output stop) ① ③ b8: — b9: — b10: — b11: RES (reset) ② ③ b12: — b13: — b14: — b15: — | Example 1: H0002 (Forward rotation) b15 b0 0 0 0 0 0 0 0 0 0 0 0 0 0 0 1 0 Example 2: H0800 low speed operation (When Pr. 184 "RES terminal function selection" is set to "0") b15 b0 0 0 0 0 1 0 0 0 0 0 0 0 0 0 0 0 |

Tab. 6-78: Run commands

- ① The signal within parentheses is the initial setting. The description changes depending on the setting of Pr. 180 to Pr. 184 "Input terminal function selection". (Refer to section 6.10.1.)
- ② The signal within parentheses is the default setting. Reset cannot be controlled by the network, bit 11 is invalid in the initial status. When using bit 11, change the signal with Pr. 184 "RES terminal function selection" (section 6.10.1) (Reset can be executed with the instruction code HFD.)
- ③ When Pr. 551 = 2 (PU Mode control source is PU connector), only forward rotation and reverse rotation can be used.

● Inverter status monitor

| Item | Instruction Code | Bits | Description | Example |
|------------------------------------|------------------|------|--|--|
| Inverter status monitor | H7A | 8 | b0: RUN (inverter running) ① b1: Forward rotation b2: Reverse rotation b3: SU (up to frequency) b4: OL (overload) b5: — b6: FU (frequency detection) ① b7: ABC (alarm) ① | Example 1: H02 (During forward rotation) b7 b0 0 0 0 0 0 0 1 0 Example 2: H80 (Stop at alarm occurrence) b7 b0 1 0 0 0 0 0 0 0 |
| Inverter status monitor (extended) | H79 | 16 | b0: RUN (inverter running) ① b1: Forward rotation b2: Reverse rotation b3: SU (up to frequency) b4: OL (overload) b5: — b6: FU (frequency detection) ① b7: ABC (alarm) ① b8: — b9: — b10: — b11: — b12: — b13: — b14: — b15: Alarm occurrence | Example 1: H0002 (During forward rotation) b15 b0 0 0 0 0 0 0 0 0 0 0 0 0 0 0 1 0 Example 2: H8080 (Stop at alarm occurrence) b15 b0 1 0 0 0 0 0 0 0 0 0 1 0 0 0 0 0 |

Tab. 6-79: Monitoring the inverter status

① The signal within parentheses is the initial setting. The description changes depending on the setting of Pr. 190 to Pr. 192 "Output terminal function selection". (Refer to section 6.10.5.)

6.19.5 Modbus-RTU communication (Pr. 117, Pr. 118, Pr. 120, Pr. 122, Pr. 343, Pr. 549)

Using the Modbus RTU communication protocol, communication operation or parameter setting can be performed from the PU connector of the inverter.

| Pr. No. | Name | Initial Value | Setting Range | Description | Parameters referred to | Refer to Section | |
|---------|--|------------------|--------------------|--|------------------------|---------------------|-------------------------|
| 117 | PU communication station number | 0 | 0 | No reply to the master ^① | — | | |
| | | | 1–247 | Inverter station number specification Set the inverter station numbers when two or more inverters are connected to one personal computer. | | | |
| 118 | PU communication speed | 96 | 48/96/ 192/384 | Communication speed The setting value × 100 equals the communication speed. (Example: 9600bps if 96) | | | |
| 120 | PU communication parity check | 2 | 0 | Without parity check Stop bit length 2bit | | | |
| | | | 1 | With odd parity check Stop bit length 1bit | | | |
| | | | 2 | With even parity check Stop bit length 1bit | | | |
| 122 | PU communication check time interval | 0 | 0 | RS-485 communication can be made. Note that a communication fault (E.PUE) occurs as soon as the inverter is switched to the operation mode with command source. | | | |
| | | | 0,1 – 999.8s | Communication check (signal loss detection) time interval If a no-communication state persists for longer than the permissible time, the inverter will come to trip (depends on Pr. 502). | | | |
| | | | 9999 | No communication check (signal loss detection) | | | |
| 343 | Communication error count | 0 | — | Displays the number of communication errors during Modbus-RTU communication (reading only) | | | |
| 502 | Stop mode selection at communication error | 0 | 0/3 | At fault occurrence | Indication | Fault output | At fault removal |
| | | | | Coasts to stop | E.PUE | Output | Stop (E.PUE) |
| | | | | 1 | Decelerates to stop | After stop E.PUE | Output after stop |
| 2 | Decelerates to stop | After stop E.PUE | Without output | Automatic restart functions | | | |
| 549 | Protocol selection | 0 | 0 | Mitsubishi inverter (computer link) protocol | | | |
| | | | 1 | Modbus-RTU protocol | | | |

The above parameter can be set when Pr. 160 "User group read selection" = 0.

- ① When Modbus-RTU communication is performed from the master with address 0 (station number 0) set, broadcast communication is selected and the inverter does not send a response message. When response from the inverter is necessary, set a value other than "0" (initial value is 0) in Pr. 117 "PU communication station number". Some functions are invalid for broadcast communication. (Refer to page 6-254.)

NOTES

When "1" (Modbus-RTU protocol) is set in Pr. 549 and "384" (38400bps) in Pr. 118, parameter unit (FR-PU04/FR-PU07) is disabled. When using the parameter unit (FR-PU04/FR-PU07), change parameter using the operation panel.

When using the Modbus-RTU protocol, set Pr. 549 "Protocol selection" to "1".

When PU connector is selected as NET mode operation source (when Pr. 550 "NET mode operation command source selection" = 2 or 9999 (initial value) without communication option), Modbus RTU communication operation can be performed. (Refer to section 6.19.2).

Communication specifications

| Item | Description | Related Parameters | |
|-------------------------------|--|---|---------|
| Communication protocol | Modbus-RTU protocol | Pr. 549 | |
| Conforming standard | EIA-485 (RS-485) | — | |
| Number of inverters connected | 1 : N (maximum 32 units), setting is 0 to 247 stations | Pr. 117 | |
| Communication speed | Can be selected from 4800/9600/19200 and 38400bps | Pr. 118 | |
| Control protocol | Asynchronous system | — | |
| Communication method | Half-duplex system | — | |
| Communication specifications | Character system | Binary (fixed to 8 bits) | — |
| | Start bit | 1bit | — |
| | Stop bit length | Select from the following three types | Pr. 120 |
| | Parity check | <ul style="list-style-type: none"> ● No parity, stop bit length: 2 bits ● Odd parity, stop bit length: 1 bit ● Even parity, stop bit length: 1 bit | |
| | Error check | CRC code check | |
| | Terminator | — | — |
| Waiting time setting | — | — | |

Tab. 6-80: Communication specifications

Outline

The Modbus protocol is the communication protocol developed by Modicon for PLC. The Modbus protocol performs serial communication between the master and slave using the dedicated message frame. The dedicated message frame has the functions that can perform data read and write. Using the functions, you can read and write the parameter values from the inverter, write the input command of the inverter, and check the operating status. In this product, the inverter data are classified in the holding register area (register addresses 40001 to 49999). By accessing the assigned holding register address, the master can communicate with the inverter which is a slave.

NOTE

There are two different serial transmission modes: ASCII (American Standard Code for Information Interchange) mode and RTU (Remote Terminal Unit) mode. This product supports only the RTU mode in which two hexadecimal coded characters are transmitted in one byte (8 bit) data. Only the communication protocol is defined by the Modbus protocol, and the physical layer is not stipulated.

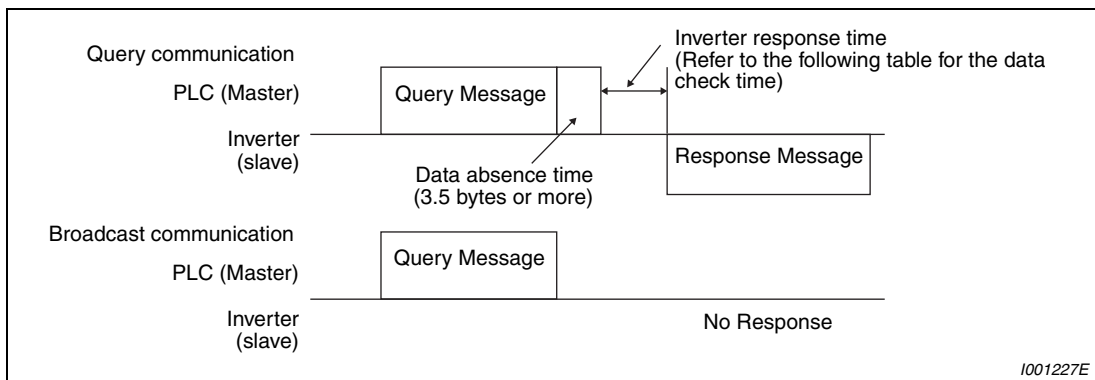

Fig. 6-128: Message format

The data check time related to different functions is shown in the table below:

| Item | Check Time |
|---|------------|
| Various monitors, operation command, frequency setting (RAM) | < 20ms |
| Parameter read/write, frequency setting (E ² PROM) | < 50ms |
| Parameter clear/all clear | < 5s |
| Reset command | — |

Tab. 6-81: Data check time

- **Query**
The master sends a message to the slave (= inverter) at the specified address.
- **Normal**
Response after receiving the query from the master, the slave executes the requested function and returns the corresponding normal response to the master.
- **Error Response**
If an invalid function code, address or data is received, the slave returns it to the master. When a response description is returned, the error code indicating that the request from the master cannot be executed is added. No response is returned for the hardware-detected error, frame error and CRC check error.
- **Broadcast**
By specifying address 0, the master can send a message to all slaves. All slaves that received the message from the master execute the requested function. In this communication, the slaves do not return a response to the master.

NOTE

The inverter executes the function independently of the inverter station number setting (Pr. 117) during broadcast communication.

Message frame (protocol)

Communication method

Basically, the master sends a query message (question) and the slave returns a response message (response). When communication is normal, Device Address and Function Code are copied as they are, and when communication is abnormal (function code or data code is illegal), bit 7 (= 80h) of Function Code is turned on and the error code is set to Data Bytes.

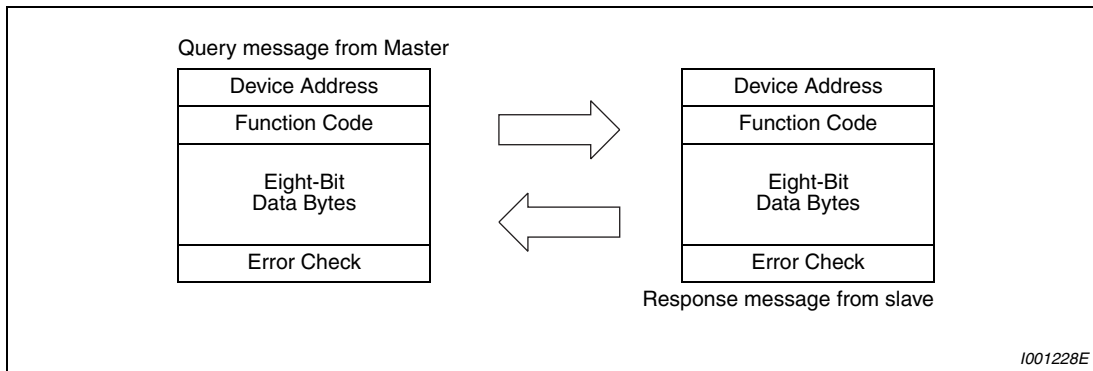

Fig. 6-129: Data transmission

The message frame consists of the four message fields as shown above. By adding the no-data time (T1: Start, End) of 3.5 characters to the beginning and end of the message data, the slave recognizes it as one message.

Protocol details

| Start | ① Address | ② Function | ③ Data | ④ CRC Check | | End |
|-------|-----------|------------|------------|-------------|-------------|-----|
| T1 | 8 bits | 8 bits | n × 8 bits | L 8 bits | H 8 bits | T1 |

| Message Field | | Description | | | | | | | | | | | | | | | | | | | | | | | | |
|---------------|----------------------------------|---|-------------------------|---------------|---------|-------------------------|-----|-----------------------|----------------------------------|------------|-----|------------------------|--------------------------------------|---------|-----|-------------|--|------------|-----|---------------------------|--|---------|-----|----------------------------------|--|------------|
| ① | Address field | The address code is 1 byte long (8 bits) and any of 0 to 247 can be set. Set "0" to send a broadcast message (all-address instruction) or any of 1 to 247 to send a message to each slave. When the slave responds, it returns the address set from the master. The value set to Pr. 117 "PU communication station number" is the slave address. | | | | | | | | | | | | | | | | | | | | | | | | |
| ② | Function field | <p>The function code is 1 byte long (8 bits) and can be set to any of 1 to 255. The master sets the function that it wants to request from the slave, and the slave performs the requested operation. The following table gives the supported function codes. An error response is returned if the set function code is other than those in the following table. When the slave returns a normal response, it returns the function code set by the master. When the slave returns an error response, it returns H80 + function code.</p> <table border="1"> <thead> <tr> <th>Code</th> <th>Function Name</th> <th>Outline</th> <th>Broadcast Communication</th> </tr> </thead> <tbody> <tr> <td>H03</td> <td>Read Holding Register</td> <td>Reads the holding register data.</td> <td>Disallowed</td> </tr> <tr> <td>H06</td> <td>Preset Single Register</td> <td>Writes data to the holding register.</td> <td>Allowed</td> </tr> <tr> <td>H08</td> <td>Diagnostics</td> <td>Function diagnosis. (communication check only)</td> <td>Disallowed</td> </tr> <tr> <td>H10</td> <td>Preset Multiple Registers</td> <td>Writes data to multiple consecutive holding registers.</td> <td>Allowed</td> </tr> <tr> <td>H46</td> <td>Read Holding Register Access Log</td> <td>Reads the number of registers that succeeded in communication last time.</td> <td>Disallowed</td> </tr> </tbody> </table> | Code | Function Name | Outline | Broadcast Communication | H03 | Read Holding Register | Reads the holding register data. | Disallowed | H06 | Preset Single Register | Writes data to the holding register. | Allowed | H08 | Diagnostics | Function diagnosis. (communication check only) | Disallowed | H10 | Preset Multiple Registers | Writes data to multiple consecutive holding registers. | Allowed | H46 | Read Holding Register Access Log | Reads the number of registers that succeeded in communication last time. | Disallowed |
| Code | Function Name | Outline | Broadcast Communication | | | | | | | | | | | | | | | | | | | | | | | |
| H03 | Read Holding Register | Reads the holding register data. | Disallowed | | | | | | | | | | | | | | | | | | | | | | | |
| H06 | Preset Single Register | Writes data to the holding register. | Allowed | | | | | | | | | | | | | | | | | | | | | | | |
| H08 | Diagnostics | Function diagnosis. (communication check only) | Disallowed | | | | | | | | | | | | | | | | | | | | | | | |
| H10 | Preset Multiple Registers | Writes data to multiple consecutive holding registers. | Allowed | | | | | | | | | | | | | | | | | | | | | | | |
| H46 | Read Holding Register Access Log | Reads the number of registers that succeeded in communication last time. | Disallowed | | | | | | | | | | | | | | | | | | | | | | | |
| ③ | Data field | The format changes depending on the function code (refer to page 6-255). Data includes the byte count, number of bytes, description of access to the holding register, etc. | | | | | | | | | | | | | | | | | | | | | | | | |
| ④ | CRC check field | The received message frame is checked for error. CRC check is performed, and 2 byte long data is added to the end of the message. When CRC is added to the message, the low-order byte is added first and is followed by the high-order byte. The CRC value is calculated by the sending side that adds CRC to the message. The receiving side recalculates CRC during message receiving, and compares the result of that calculation and the actual value received in the CRC check field. If these two values do not match, the result is defined as error. | | | | | | | | | | | | | | | | | | | | | | | | |

Tab. 6-82: Protocol details

Message format types

The message formats corresponding to the function codes in Tab. 6-82 will be explained.

- Read holding register data (H03 or 03)
Can read the description of system environment variables, real-time monitor, alarm history, and inverter parameters assigned to the holding register area. (Refer to the register list on page 6-263.)

Query Message

| ① Slave Address | ② Function | ③ Starting Address | | ④ No. of Points | | CRC Check | |
|-----------------|-----------------|--------------------|---------------|-----------------|---------------|---------------|---------------|
| (8 bits) | H03 (8 bits) | H (8 bits) | L (8 bits) | H (8 bits) | L (8 bits) | L (8 bits) | H (8 bits) |

Response message

| ① Slave Address | ② Function | ⑤ Byte Count | ⑥ Data | | | CRC Check | |
|-----------------|-----------------|--------------|---------------|---------------|--------------------|---------------|---------------|
| (8 bits) | H03 (8 bits) | (8 bits) | H (8 bits) | L (8 bits) | ... n × 16 bits | L (8 bits) | H (8 bits) |

| Message | | Description |
|---------|------------------|---|
| ① | Slave Address | Set the address to which the message will be sent. Broadcast communication cannot be made (0 is invalid) |
| ② | Function | Set H03. |
| ③ | Starting Address | Set the address at which holding register data read will be started. Starting address = starting register address (decimal) + 40001 For example, setting of the starting address 0001 reads the data of the holding register 40002. |
| ④ | No. of Points | Set the number of holding registers from which data will be read. The number of registers from which data can be read is a maximum of 125. |

Tab. 6-83: Description of the query message

| Message | | Description |
|---------|------------|---|
| ⑤ | Byte Count | The setting range is H02 to H14 (2 to 20). Twice greater than the No. of Points specified at ④ is set. |
| ⑥ | Data | The number of data specified at ④ is set. Data are read in order of Hi byte and Lo byte, and set in order of starting address data, starting address + 1 data, starting address + 2 data, ... |

Tab. 6-84: Description of normal response

Example ▾

To read the register values of 41004 (Pr. 4) to 41006 (Pr. 6) from the slave address 17 (H11).

Query message

| Slave Address | Function | Starting Address | | No. of Points | | CRC Check | |
|-----------------|-----------------|------------------|-----------------|-----------------|-----------------|-----------------|-----------------|
| H11 (8 bits) | H03 (8 bits) | H03 (8 bits) | HEB (8 bits) | H00 (8 bits) | H03 (8 bits) | H77 (8 bits) | H2B (8 bits) |

Normal response (Response message)

| Slave Address | Function | Byte Count | Data | | | | | | CRC Check | |
|-----------------|-----------------|-----------------|-----------------|-----------------|-----------------|-----------------|-----------------|-----------------|-----------------|-----------------|
| H11 (8 Bits) | H03 (8 Bits) | H06 (8 Bits) | H17 (8 Bits) | H70 (8 Bits) | H0B (8 Bits) | HB8 (8 Bits) | H03 (8 Bits) | HE8 (8 Bits) | H2C (8 Bits) | HE6 (8 Bits) |

Read value:

Register 41004 (Pr. 4): H1770 (60.00Hz)

Register 41005 (Pr. 5): H0BB8 (30.00Hz)

Register 41006 (Pr. 6): H03E8 (10.00Hz)

△

- Write multiple holding register data (H06 or 06)
You can write the description of system environment variables and inverter parameters assigned to the holding register area. (Refer to the register list on page 6-263).

Query message

| ① Slave Address | ② Function | ③ Register Address | | ④ Preset Data | | CRC Check | |
|-----------------|-----------------|--------------------|---------------|---------------|---------------|---------------|---------------|
| (8 bits) | H06 (8 bits) | H (8 bits) | L (8 bits) | H (8 bits) | L (8 bits) | L (8 bits) | H (8 bits) |

Normal response (Response message)

| ① Slave Address | ② Function | ③ Register Address | | ④ Preset Data | | CRC Check | |
|-----------------|-----------------|--------------------|---------------|---------------|---------------|---------------|---------------|
| (8 bits) | H06 (8 bits) | H (8 bits) | L (8 bits) | H (8 bits) | L (8 bits) | L (8 bits) | H (8 bits) |

| Message | | Description |
|---------|------------------|---|
| ① | Slave Address | Set the address to which the message will be sent. Setting of address 0 enables broadcast communication. |
| ② | Function | Set H06. |
| ③ | Register Address | Set the address of the holding register to which data will be written. Register address = holding register address (decimal) + 40001 For example, setting of register address 0001 writes data to the holding register address 40002. |
| ④ | Preset Data | Set the data that will be written to the holding register. The written data is fixed to 2 bytes. |

Tab. 6-85: Description of the query message

The normal response data ① to ④ (including CRC check) of the normal response are the same as those of the query message. No response is made for broadcast communication.

Example ▾

To write 60Hz (H1770) to 40014 (running frequency RAM) at slave address 5 (H05).

Query message

| Slave Address | Function | Register Address | | Preset Data | | CRC Check | |
|-----------------|-----------------|------------------|-----------------|-----------------|-----------------|-----------------|-----------------|
| H05 (8 bits) | H06 (8 bits) | H00 (8 bits) | H0D (8 bits) | H17 (8 bits) | H70 (8 bits) | H17 (8 bits) | H99 (8 bits) |

Normal Response (Response message):
Same data as the query message.



NOTE

For broadcast communication, no response is returned in reply to a query. Therefore, the next query must be made when the inverter processing time has elapsed after the previous query.

- Function diagnosis (H08 or 08)

A communication check can be made since the query message sent is returned unchanged as a response message (function of subfunction code H00). Subfunction code H00 (Return Query Data).

Query message

| ① Slave Address | ② Function | ③ Subfunction | | ④ Data | | CRC Check | |
|-----------------|-----------------|-----------------|-----------------|---------------|---------------|---------------|---------------|
| (8 bits) | H08 (8 bits) | H00 (8 bits) | H00 (8 bits) | H (8 bits) | L (8 bits) | L (8 bits) | H (8 bits) |

Normal response (Response message)

| ① Slave Address | ② Function | ③ Subfunction | | ④ Data | | CRC Check | |
|-----------------|-----------------|-----------------|-----------------|---------------|---------------|---------------|---------------|
| (8 bits) | H08 (8 bits) | H00 (8 bits) | H00 (8 bits) | H (8 bits) | L (8 bits) | L (8 bits) | H (8 bits) |

| Message | | Description |
|---------|---------------|--|
| ① | Slave Address | Set the address to which the message will be sent. Broadcast communication cannot be made (0 is invalid) |
| ② | Function | Set H08. |
| ③ | Subfunction | Set H0000. |
| ④ | Data | Any data can be set if it is 2 bytes long. The setting range is H0000 to HFFFF. |

Tab. 6-86: Description of the query message

The normal response data ① to ④ (including CRC check) of the normal response are the same as those of the query message.

- Write multiple holding register data (H10 or 16)
You can write data to multiple holding registers.

Query message

| ① Slave Address | ② Function | ③ Starting Address | | ④ No. of Registers | | ⑤ Byte Count | ⑥ Data | | | | CRC Check | |
|-----------------|-----------------|--------------------|---------------|--------------------|---------------|---------------|---------------|---------------|-----|----------------------------|---------------|---------------|
| (8 Bits) | H10 (8 Bits) | H (8 Bits) | L (8 Bits) | H (8 Bits) | L (8 Bits) | L (8 Bits) | H (8 Bits) | L (8 Bits) | ... | $n \times 2 \times 8$ Bits | L (8 Bits) | H (8 Bits) |

Normal response (Response message)

| ① Slave Address | ② Function | ③ Starting Address | | ④ No. of Registers | | CRC Check | |
|-----------------|-----------------|--------------------|---------------|--------------------|---------------|---------------|---------------|
| (8 bits) | H10 (8 bits) | H (8 bits) | L (8 bits) | H (8 bits) | L (8 bits) | L (8 bits) | H (8 bits) |

| Message | | Description |
|---------|------------------|---|
| ① | Slave Address | Set the address to which the message will be sent. Setting of address 0 enables broadcast communication. |
| ② | Function | Set H10. |
| ③ | Starting Address | Set the address where holding register data write will be started. Starting address = starting register address (decimal) + 40001 For example, setting of the starting address 0001 reads the data of the holding register 40002. |
| ④ | No. of Points | Set the number of holding registers where data will be written. The number of registers where data can be written is a maximum of 125. |
| ⑤ | Byte Count | The setting range is H02 to HFA (0 to 250). Set twice greater than the value specified at ④. |
| ⑥ | Data | Set the data specified by the number specified at ④. The written data are set in order of Hi byte and Lo byte, and arranged in order of the starting address data, starting address + 1 data, starting address + 2 data ... |

Tab. 6-87: Description of the query message

The normal response data ① to ④ (including CRC check) of the normal response are the same as those of the query message.

Example ▽

To write 0.5s (H05) to 41007 (Pr. 7) at the slave address 25 (H19) and 1s (H0A) to 41008 (Pr. 8).

Query message

| Slave Address | Function | Starting Address | | No. of Registers | | Byte Count | Data | | | | CRC Check | |
|-----------------|-----------------|------------------|-----------------|------------------|-----------------|-----------------|-----------------|-----------------|-----------------|-----------------|-----------------|-----------------|
| H19 (8 bits) | H10 (8 bits) | H03 (8 bits) | HEE (8 bits) | H00 (8 bits) | H02 (8 bits) | H04 (8 bits) | H00 (8 bits) | H05 (8 bits) | H00 (8 bits) | H0A (8 bits) | H86 (8 bits) | H3D (8 bits) |

Normal response (Response message)

| Slave Address | Function | Starting Address | | No. of Registers | | Byte Count | CRC Check | |
|-----------------|-----------------|------------------|-----------------|------------------|-----------------|-----------------|-----------------|-----------------|
| H19 (8 bits) | H10 (8 bits) | H03 (8 bits) | HEE (8 bits) | H00 (8 bits) | H02 (8 bits) | H04 (8 bits) | H22 (8 bits) | H61 (8 bits) |



- Read holding register access log (H46 or 70)
A response can be made to a query made by the function code H03 or H10.
The starting address of the holding registers that succeeded in access during previous communication and the number of successful registers are returned.
In response to the query for other than the above function code, 0 is returned for the address and number of registers.

Query message

| ① Slave Address | ② Function | CRC Check | |
|-----------------|-----------------|---------------|---------------|
| (8 bits) | H46 (8 bits) | L (8 bits) | H (8 bits) |

Normal response (Response message)

| ① Slave Address | ② Function | ③ Starting Address | | ④ No. of Points | | CRC Check | |
|-----------------|-----------------|--------------------|---------------|-----------------|---------------|---------------|---------------|
| (8 bits) | H46 (8 bits) | H (8 bits) | L (8 bits) | H (8 bits) | L (8 bits) | L (8 bits) | H (8 bits) |

| Message | | Description |
|---------|---------------|--|
| ① | Slave Address | Set the address to which the message will be sent. Broadcast communication cannot be made (0 is invalid) |
| ② | Function | Set H46. |

Tab. 6-88: Description of the query message

| Message | | Description |
|---------|------------------|--|
| ③ | Starting Address | The starting address of the holding registers that succeeded in access is returned. Starting address = starting register address (decimal) + 40001 For example, when the starting address 0001 is returned, the address of the holding register that succeeded in access is 40002. |
| ④ | No. of Points | The number of holding registers that succeeded in access is returned. |

Tab. 6-89: Description of normal response

Example ▾

To read the successful register starting address and successful count from the slave address 25 (H19).

Query message

| Slave Address | Function | CRC Check | |
|-----------------|-----------------|-----------------|-----------------|
| H19 (8 bits) | H46 (8 bits) | H8B (8 bits) | HD2 (8 bits) |

Normal response (Response message)

| Slave Address | Function | Starting Address | | No. of Points | | CRC Check | |
|-----------------|-----------------|------------------|-----------------|-----------------|-----------------|-----------------|-----------------|
| H19 (8 bits) | H10 (8 bits) | H03 (8 bits) | HEE (8 bits) | H00 (8 bits) | H02 (8 bits) | H22 (8 bits) | H61 (8 bits) |

Success of two registers at starting address 41007 (Pr. 7) is returned.

△

- Error response

An error response is returned if the query message received from the master has an illegal function, address or data. No response is returned for a parity, CRC, overrun, framing or busy error.

NOTE

No response message is sent in the case of broadcast communication also.

Error response (Response message)

| ① Slave Address | ② Function | ③ Exception Code | CRC Check | |
|-----------------|----------------------------|------------------|---------------|---------------|
| (8 bits) | H80 + Function (8 bits) | (8 bits) | L (8 bits) | H (8 bits) |

| Message | Description |
|------------------|--|
| ① Slave address | Set the address received from the master. |
| ② Function | The master-requested function code + H80 is set. |
| ③ Exception code | The code in the following table is set. |

Tab. 6-90: Description of response data

| Code | Error Item | Description |
|------|---|---|
| 01 | ILLEGAL FUNCTION (Function code illegal) | The set function code in the query message from the master cannot be handled by the slave. |
| 02 | ILLEGAL DATA ADDRESS ① (Address illegal) | The set register address in the query message from the master cannot be handled by the inverter. (No parameter, parameter read disabled, parameter write disabled) |
| 03 | ILLEGAL DATA VALUE (Data illegal) | The set data in the query message from the master cannot be handled by the inverter. (Out of parameter write range, mode specified, other error) |

Tab. 6-91: Error code list

① An error will not occur in the following cases:

- Function code H03 (Read Holding Register Data)
When the No. of Points is 1 or more and there is one or more holding registers from which data can be read.
- Function code H10 (Write Multiple Holding Register Data)
When the No. of Points is 1 or more and there is 1 or more holding registers to which data can be written.

Namely, when the function code H03 or H10 is used to access multiple holding registers, an error will not occur if a non-existing holding register or read disabled or write disabled holding register is accessed.

NOTES

An error will occur if all accessed holding registers do not exist.

Data read from a non-existing holding register is 0, and data written there is invalid.

To detect the mistakes of message data from the master, they are checked for the following errors. If an error is detected, an alarm stop will not occur.

| Error Item | Error Definition | Inverter Side Operation |
|---------------------|--|--|
| Parity error | The data received by the inverter differs from the specified parity (Pr. 334 setting). | Pr. 343 is increased by 1 at error occurrence. The terminal LF is output at error occurrence. |
| Framing error | The data received by the inverter differs from the specified stop bit length (Pr. 333). | |
| Overrun error | The following data was sent from the master before the inverter completes data receiving. | |
| Message frame error | The message frame data length is checked, and the received data length of less than 4 bytes is regarded as an error. | |
| CRC check error | A mismatch found by CRC check between the message frame data and calculation result is regarded as an error. | |

Tab. 6-92: Error check item

Modbus registers

● System environment variable

| Register | Definition | Read/write | Remarks |
|----------|--|------------|---|
| 40002 | Inverter reset | Write | Any value can be written |
| 40003 | Parameter clear | Write | Set H965A as a written value. |
| 40004 | All parameter clear | Write | Set H99AA as a written value. |
| 40006 | Parameter clear ^① | Write | Set H5A96 as a written value. |
| 40007 | All parameter clear ^① | Write | Set HAA99 as a written value. |
| 40009 | Inverter status/control input instruction ^② | Read/write | Refer to Tab. 6-94 |
| 40010 | Operation mode/inverter setting ^③ | Read/write | Refer to Tab. 6-95 |
| 40014 | Running frequency (RAM value) | Read/write | According to the Pr. 37 setting, the frequency and selectable speed are in 1r/min increments. |
| 40015 | Running frequency (E ² PROM value) | Write | |

Tab. 6-93: System environment variable

- ① The communication parameter values are not cleared.
- ② For write, set the data as a control input instruction. For read, data is read as an inverter operating status.
- ③ For write, set data as the operation mode setting. For read, data is read as the operation mode status.

| Bit | Definition | |
|-----|--|---------------------------------------|
| | Control input instruction | Inverter status |
| 0 | Stop command | RUN (inverter running) ^② |
| 1 | Forward rotation command | Forward rotation |
| 2 | Reverse rotation command | Reverse rotation |
| 3 | RH (high speed operation command) ^① | SU (up to frequency) |
| 4 | RM (middle speed operation command) ^① | OL (overload) |
| 5 | RL (low speed operation command) ^① | 0 |
| 6 | 0 | FU (frequency detection) ^② |
| 7 | RT (second function selection) | ABC (Alarm) ^② |
| 8 | AU (current input selection) | 0 |
| 9 | 0 | 0 |
| 10 | MRS (output stop) ^① | 0 |
| 11 | 0 | 0 |
| 12 | RES (reset) ^① | 0 |
| 13 | 0 | 0 |
| 14 | 0 | 0 |
| 15 | 0 | Alarm |

Tab. 6-94: Inverter status/control input instruction

- ^① The signal within parentheses is the default setting. The description changes depending on the setting of Pr. 180 to Pr. 184 "Input terminal function selection". (Refer to section 6.10.1.) Each assigned signal is valid or invalid depending on NET. (Refer to section 6.18.3.)
- ^② The signal within parentheses is the default setting. Definitions change according to the Pr. 190 to Pr. 192 "Output terminal function selection". (Refer to section 6.10.5.)

| Operation Mode | Read Value | Written Value |
|----------------|------------|---------------|
| EXT | H0000 | H0010 |
| PU | H0001 | — |
| EXT JOG | H0002 | — |
| PU JOG | H0003 | — |
| NET | H0004 | H0014 |
| PU + EXT | H0005 | — |

Tab. 6-95: Operation mode/inverter setting

The restrictions depending on the operation mode changes according to the computer link specifications.

● Real-time monitor

Refer to section 6.11.2 for details of the monitor description.

| Register | Description | Unit | Register | Description | Unit |
|----------|---|----------|----------|----------------------------------|------|
| 40201 | Output frequency/ Speed ① | 0.01Hz/1 | 40220 | Cumulative energizing time | 1h |
| 40202 | Output current | 0.01A | 40223 | Actual operation time | 1h |
| 40203 | Output voltage | 0.1V | 40224 | Motor load factor | 0.1% |
| 40205 | Frequency setting/ speed setting ① | 0.01Hz/1 | 40225 | Cumulative power | 1kWh |
| 40207 | Motor torque | 0.1% | 40252 | PID set point | 0.1% |
| 40208 | Converter output voltage | 0.1V | 40253 | PID measurement value | 0.1% |
| 40209 | Regenerative brake duty | 0.1% | 40254 | PID deviation value | 0.1% |
| 40210 | Electronic thermal relay function load factor | 0.1% | 40258 | Option input terminal status 1 ④ | — |
| 40211 | Output current peak value | 0.01A | 40259 | Option input terminal status 2 ⑤ | — |
| 40212 | Converter output voltage peak value | 0.1V | 40260 | Option output terminal status ⑥ | — |
| 40214 | Output power | 0.01kW | 40261 | Motor thermal load factor | 0.1% |
| 40215 | Input terminal status ② | — | 40262 | Inverter thermal load factor | 0.1% |
| 40216 | Output terminal status ③ | — | — | — | — |

Tab. 6-96: Real-time monitor

① When Pr. 37 = "0.01 to 9998", displayed in integral number.

② Input terminal monitor details

| | | | | | | | | | | | | | | | |
|-----|---|---|---|---|-----|---|-----|---|----|----|----|---|---|-----|-----|
| b15 | | | | | | | | | | | | | | b0 | |
| — | — | — | — | — | RES | — | MRS | — | RH | RM | RL | — | — | STR | STF |

③ Output terminal monitor details

| | | | | | | | | | | | | | | | |
|-----|---|---|---|---|---|---|---|---|---|---|-----|----|---|----|-----|
| b15 | | | | | | | | | | | | | | b0 | |
| — | — | — | — | — | — | — | — | — | — | — | ABC | FU | — | — | RUN |

④ Details of option input terminal monitor 1 (input terminal status of FR-A7AX E kit)
(All terminals are off when an option is not fitted.)

| | | | | | | | | | | | | | | | |
|-----|-----|-----|-----|-----|-----|----|----|----|----|----|----|----|----|----|----|
| b15 | | | | | | | | | | | | | | b0 | |
| X15 | X14 | X13 | X12 | X11 | X10 | X9 | X8 | X7 | X6 | X5 | X4 | X3 | X2 | X1 | X0 |

⑤ Details of option input terminal monitor 2 (input terminal status of FR-A7AX E kit)
(All terminals are off when an option is not fitted.)

| | | | | | | | | | | | | | | | |
|-----|---|---|---|---|---|---|---|---|---|---|---|---|---|----|----|
| b15 | | | | | | | | | | | | | | b0 | |
| — | — | — | — | — | — | — | — | — | — | — | — | — | — | — | DY |

⑥ Details of option output terminal monitor (output terminal status of FR-A7AY E kit/A7AR E kit)(All terminals are off when an option is not fitted.)

| | | | | | | | | | | | | | | | |
|-----|---|---|---|---|---|-----|-----|-----|----|----|----|----|----|----|----|
| b15 | | | | | | | | | | | | | | b0 | |
| — | — | — | — | — | — | RA3 | RA2 | RA1 | Y6 | Y5 | Y4 | Y3 | Y2 | Y1 | Y0 |

● Parameter

| Parameters | Register | Parameter Name | Read/write | Remarks |
|------------|-------------|---|------------|--|
| 0-999 | 41000-41999 | Refer to the parameter list (Tab. 6-1) for the parameter names. | Read/write | The parameter number + 41000 is the register number. |
| C2 (902) | 41902 | Terminal 2 frequency setting bias (frequency) | Read/write | |
| C3 (902) | 42092 | Terminal 2 frequency setting bias (analog value) | Read/write | The analog value (%) set to C3 (902) is read. |
| | 43902 | Terminal 2 frequency setting bias (terminal analog value) | Read | The analog value (%) of the voltage (current) applied to the terminal 2 is read. |
| 125 (903) | 41903 | Terminal 2 frequency setting gain (frequency) | Read/write | |
| C4 (903) | 42093 | Terminal 2 frequency setting gain (analog value) | Read/write | The analog value (%) set to C4 (903) is read. |
| | 43903 | Terminal 2 frequency setting gain (terminal analog value) | Read | The analog value (%) of the voltage (current) applied to the terminal 2 is read. |
| C5 (904) | 41904 | Terminal 4 frequency setting bias (frequency) | Read/write | |
| C6 (904) | 42094 | Terminal 4 frequency setting bias (analog value) | Read/write | The analog value (%) set to C6 (904) is read. |
| | 43904 | Terminal 4 frequency setting bias (terminal analog value) | Read | The analog value (%) of the current (voltage) applied to the terminal 4 is read. |
| 126 (905) | 41905 | Terminal 4 frequency setting gain (frequency) | Read/write | |
| C7 (905) | 42095 | Terminal 4 frequency setting gain (analog value) | Read/write | The analog value (%) set to C7 (905) is read. |
| | 43905 | Terminal 4 frequency setting gain (terminal analog value) | Read | The analog value (%) of the current (voltage) applied to the terminal 4 is read. |

Tab. 6-97: Parameter

● Fault history

| Register | Definition | Read/write | Remarks |
|----------|-----------------|------------|---|
| 40501 | Fault history 1 | Read/write | Being 2 bytes in length, the data is stored as "H00□□". The error code can be referred to in the low-order 1 byte. Performing write using the register 40501 batch-clears the alarm history. Set any value as data. |
| 40502 | Fault history 2 | Read | |
| 40503 | Fault history 3 | Read | |
| 40504 | Fault history 4 | Read | |
| 40505 | Fault history 5 | Read | |
| 40506 | Fault history 6 | Read | |
| 40507 | Fault history 7 | Read | |
| 40508 | Fault history 8 | Read | |

Tab. 6-98: Fault history

| Data | Description | Data | Description | Data | Description |
|------|------------------|------|-------------|------|-------------|
| H00 | No fault present | H70 | E.BE | HC8 | E.USB |
| H10 | E.OC1 | H80 | E.GF | HD8 | E.MB4 |
| H11 | E.OC2 | H81 | E.LF | HD9 | E.MB5 |
| H12 | E.OC3 | H90 | E.OHT | HDA | E.MB6 |
| H20 | E.OV1 | HA1 | E.OP1 | HDB | E.MB7 |
| H21 | E.OV2 | HB0 | E.PE | HF1 | E.1 |
| H22 | E.OV3 | HB1 | E.PUE | HF5 | E.5 |
| H30 | E.THT | HB2 | E.RET | HF6 | E.6 |
| H31 | E.THM | HB3 | E.PE2 | HF7 | E.7 |
| H40 | E.FIN | HC0 | E.CPU | HFD | E.13 |
| H52 | E.ILF | HC5 | E.IOH | | |
| H60 | E.OLT | HC7 | E.AIE | | |

Tab. 6-99: Fault code list

NOTE

Refer to section 7.1 for details of fault definition.

Communication error count (Pr. 343)

You can check the cumulative number of communication errors.

| Parameters | Setting Range | Minimum Setting Range | Initial Value |
|------------|---------------|-----------------------|---------------|
| 343 | (Read only) | 1 | 0 |

Tab. 6-100: Number of communication errors

NOTE

The number of communication errors is temporarily stored into the RAM. As it is not stored into the E²PROM, performing a power supply reset or inverter reset clears the value to 0.

Output terminal LF "alarm output (communication error warnings)"

During a communication error, the alarm signal (LF signal) is output by open collector output. Assign the used terminal using any of Pr. 190 to Pr. 192 "Output terminal function selection".

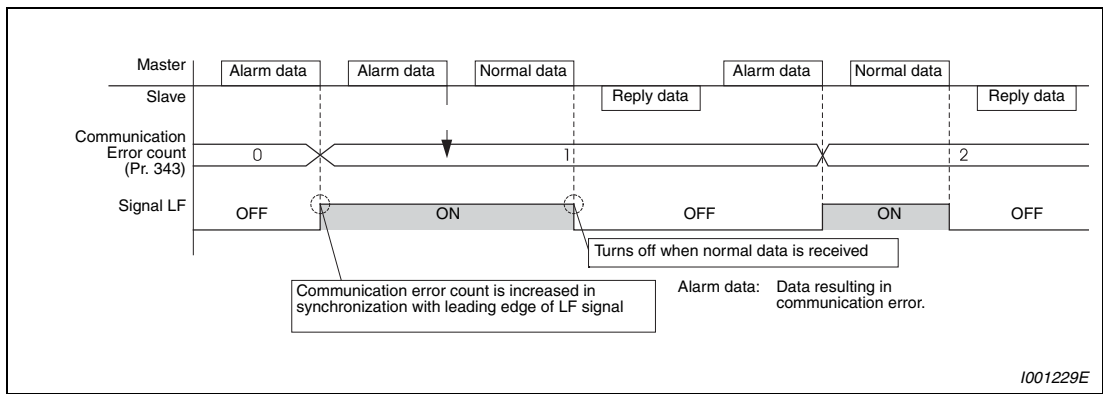

Fig. 6-130: Output of the LF signal

NOTE

The LF signal can be assigned to the output terminal using any of Pr. 190 to Pr.192. Changing the terminal assignment may affect the other functions. Make setting after confirming the function of each terminal.

6.19.6 USB communication (Pr. 547, Pr. 548)

Inverter setup can be easily performed using the FR Configurator by connecting the inverter and personal computer with a USB cable. A personal computer and inverter can be easily connected with one USB cable.

| Pr. No. | Name | Initial Value | Setting Range | Description | Parameters referred to | Refer to Section |
|------------|---|---------------|---------------|---|--|------------------|
| 547 | USB communication station number ① | 0 | 0-31 | Inverter station number specification | 551 PU mode operation command source selection | 6.18.3 |
| 548 | USB communication check time interval ① | 9999 | 0 | USB communication is possible Trips in the PU operation mode (E.USB) | | |
| | | | 0.1-999.8s | Sets the interval of communication check time. If a no-communication state persists for longer than the permissible time, the inverter will come to trip (E.USB). | | |
| | | | 9999 | No communication check | | |

① Changed setting value is made valid when powering on or resetting the inverter.

| Specification | Description |
|--------------------|---|
| Interface | Conforms to USB1.1 |
| Transmission speed | 12Mbps |
| Wiring Length | 5m |
| Connector | USB mini B connector (receptacle mini B type) |
| Power supply | Self-power supply |

Tab. 6-101: USB communication specifications

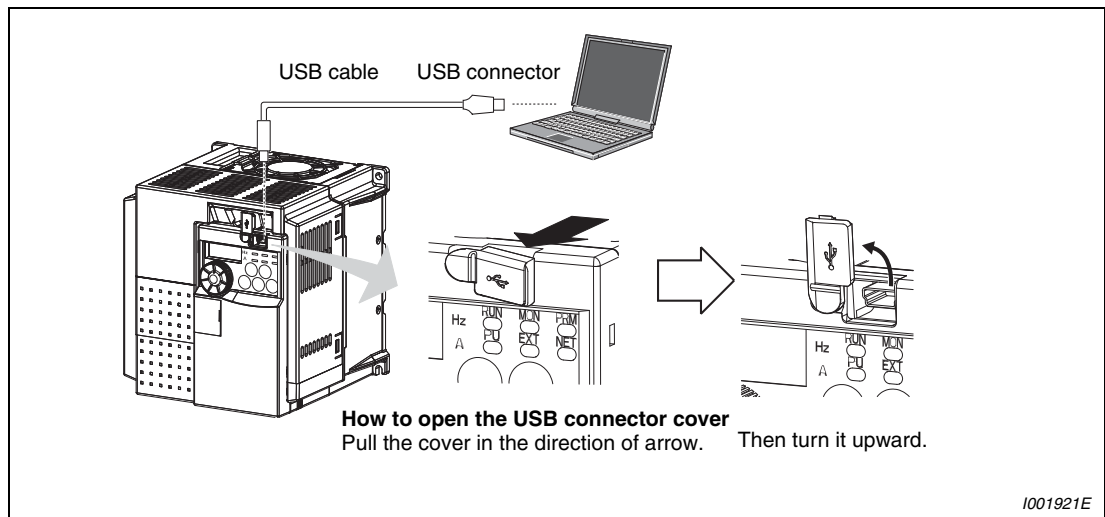

Fig. 6-131: Connection to the USB connector

You can perform parameter setting and monitoring with the FR Configurator. Refer to the instruction manual of the FR Configurator for details.

6.20 Special operation

| Purpose | Parameters that must be set | | Refer to Section |
|--|--------------------------------------|---------------------------------|------------------|
| Perform process control such as pump and air volume. | PID control | Pr. 127–Pr. 134 | 6.20.1 |
| Dancer control | PID control (dancer control setting) | Pr. 44, Pr. 45, Pr. 128–Pr. 134 | 6.20.2 |
| Frequency control appropriate for load torque | Droop control | Pr. 286, Pr. 287 | 6.20.3 |
| Avoid over voltage alarm due to regeneration by automatic adjustment of output frequency | Regeneration avoidance function | Pr. 882–Pr. 886 | 6.20.4 |

6.20.1 PID control (Pr. 127 to Pr. 134)

The inverter can be used to exercise process control, e.g. flow rate, air volume or pressure.

The terminal 2 input signal or parameter setting is used as a set point and the terminal 4 input signal used as a feedback value to constitute a feedback system for PID control.

| Pr. No. | Name | Initial Value | Setting Range | Description | Parameters referred to | Refer to Section | | |
|------------|--|---------------|---------------|---|---|--|--|--------|
| 127 | PID control automatic switchover frequency | 9999 | 0–400Hz | Set the frequency at which the control is automatically changed to PID control. | 59 Remote function selection | 6.6.3 | | |
| | | | 9999 | Without PID automatic switchover function | | | 73 Analog input selection | 6.16.1 |
| 128 | PID action selection | 0 | 0 | PID action is not performed | 79 Operation mode selection | 6.18.1 | | |
| | | | 20 | PID reverse action | Measured value (terminal 4) Set value (terminal 2 or Pr. 133) | 178–184 Input terminal function selection | 6.10.1 | |
| | | | 21 | PID forward action | | | | |
| | | | 40 | PID reverse action | Addition method: fixed | For dancer control set point (Pr. 133), measured value (terminal 4) main speed (frequency command of the operation mode) | 190–192 Output terminal function selection | 6.10.5 |
| | | | 41 | PID forward action | | | | |
| | | | 42 | PID reverse action | Addition method: ratio | Deviation value signal input (LonWorks, CC-Link communication) | 261 Power failure stop selection | 6.12.2 |
| | | | 43 | PID forward action | | | | |
| | | | 50 | PID reverse action | Deviation value signal input (LonWorks, CC-Link communication) | C2 (Pr. 902) – C7 (Pr. 905) Frequency setting voltage (current) bias/gain | 6.16.3 | |
| | | | 51 | PID forward action | | | | |
| | | | 60 | PID reverse action | Measured value, set point input (LonWorks, CC-Link communication) | | | |
| | | | 61 | PID forward action | | | | |
| 129 | PID proportional band ① | 100 % | 0.1 – 1000% | If the proportional band is narrow (parameter setting is small), the manipulated variable varies greatly with a slight change of the measured value. Hence, as the proportional band narrows, the response sensitivity (gain) improves but the stability deteriorates, e.g. hunting occurs. Gain $K_p = 1/\text{proportional band}$ | | | | |
| | | | 9999 | No proportional control | | | | |
| 130 | PID integral time ① | 1 s | 0,1 – 3600s | For deviation step input, time (Ti) required for only the integral (I) action to provide the same manipulated variable as that for the proportional (P) action. As the integral time decreases, the set point is reached earlier but hunting occurs more easily. | | | | |
| | | | 9999 | No integral control. | | | | |
| 131 | PID upper limit | 9999 | 0–100% | Maximum value If the feedback value exceeds the setting, the FUP signal is output. The maximum input (20mA/5V/10V) of the measured value (terminal 4) is equivalent to 100%. | | | | |
| | | | 9999 | No function | | | | |
| 132 | PID lower limit | 9999 | 0–100% | Minimum frequency If the process value falls below the setting range, the FDN signal is output. The maximum input (20mA/5V/10V) of the measured value (terminal 4) is equivalent to 100%. | | | | |
| | | | 9999 | No function | | | | |
| 133 | PID action set point ① | 9999 | 0–100% | Used to set the set point for PID control. | | | | |
| | | | 9999 | Terminal 2 input is the set point. | | | | |
| 134 | PID differential time ① | 9999 | 0,01 – 10.00s | For deviation ramp input, time (Td) required for providing only the manipulated variable for the proportional (P) action. As the differential time increases, greater response is made to a deviation change. | | | | |
| | | | 9999 | No differential control. | | | | |

The above parameters can be set when Pr. 160 "User group read selection" = 0.

① Pr. 129, Pr. 130, Pr. 133 and Pr. 134 can be set during operation. They can also be set independently of the operation mode.

PID control basic configuration

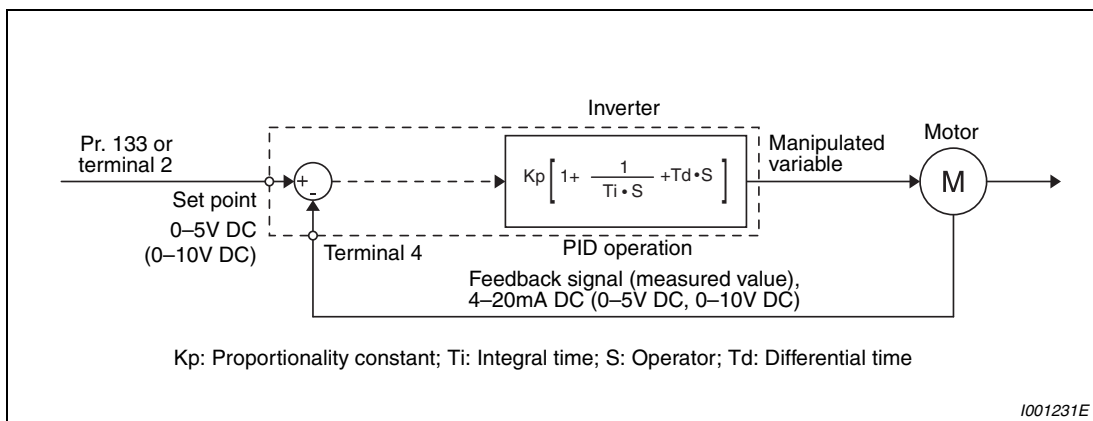

Fig. 6-132: System configuration when Pr. 128 = 20 or 21 (set/feedback value at the inverter)

PI action

A combination of P action (P) and I action (I) for providing a manipulated variable in response to deviation and changes with time.

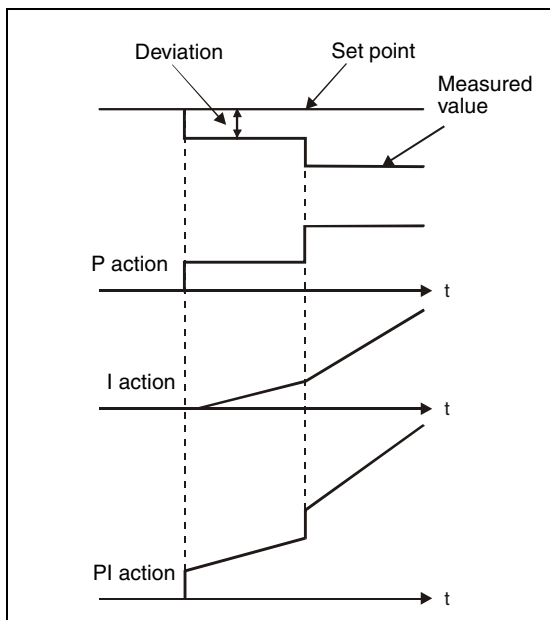

Fig. 6-133: Operation example for stepped changes of measured value

I000045C

PD action

A combination of P action (P) and differential control action (D) for providing a manipulated variable in response to deviation speed to improve the transient characteristic.

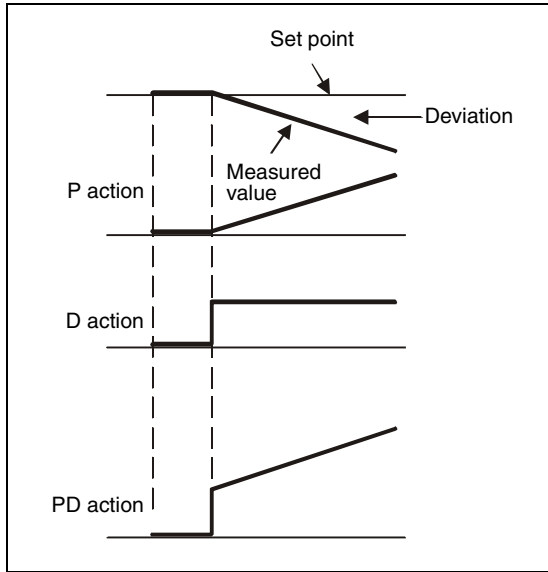

Fig. 6-134:

Operation example for proportional changes of measured value

1000046C

PID action

The PI action and PD action are combined to utilize the advantages of both actions for control.

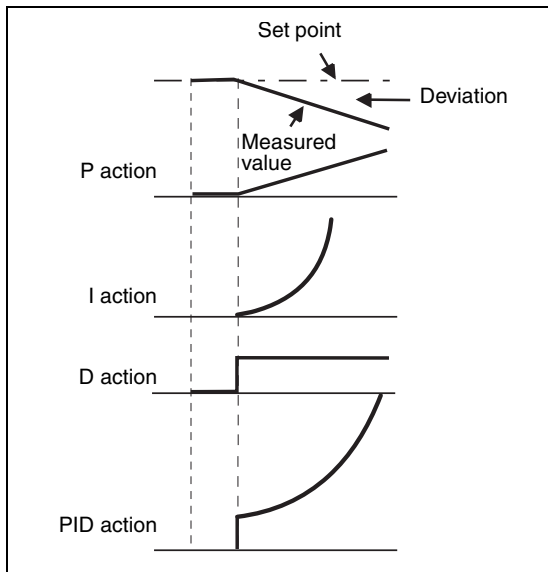

Fig. 6-135:

Operation example for proportional changes of measured value

1001233E

Reverse action

Increases the manipulated variable f_i (output frequency) if deviation $X = (\text{set point} - \text{measured value})$ is positive, and decreases the manipulated variable if deviation is negative.

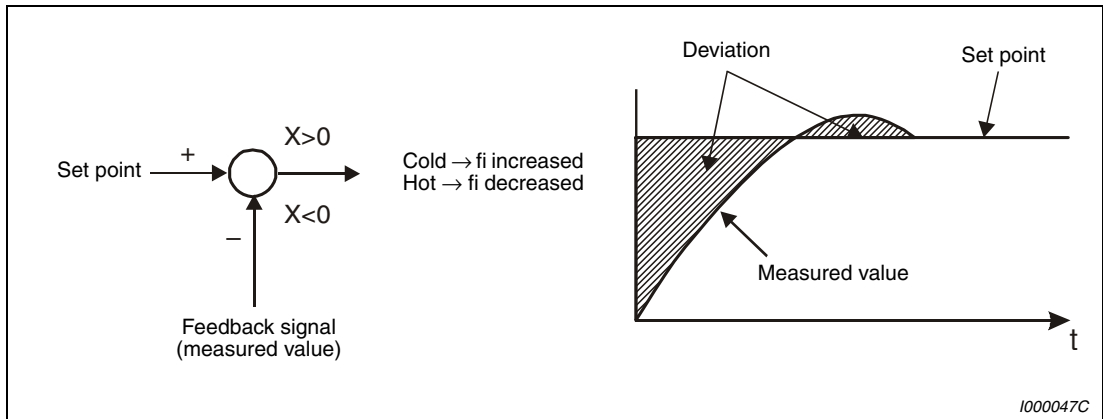

Fig. 6-136: Heater

Forward action

Increases the manipulated variable (output frequency) if deviation $X = (\text{set point} - \text{measured value})$ is negative, and decreases the manipulated variable if deviation is positive.

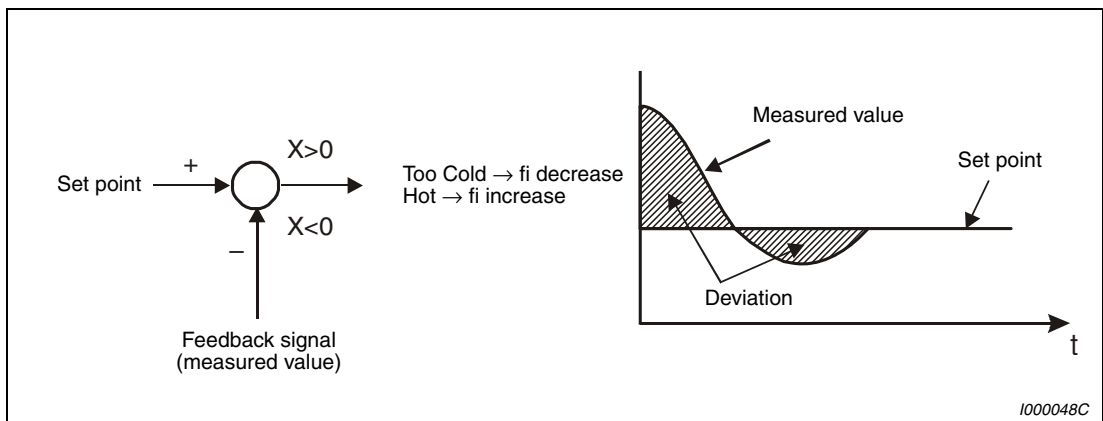

Fig. 6-137: Cooling

Relationships between deviation and manipulated variable (output frequency).

| | Deviation | |
|----------------|-----------|----------|
| | Positive | Negative |
| Reverse action | ↗ | ↘ |
| Forward action | ↘ | ↗ |

Tab. 6-102: Relationships between deviation and manipulated variable

Connection diagram

The following graphic shows a typical application:

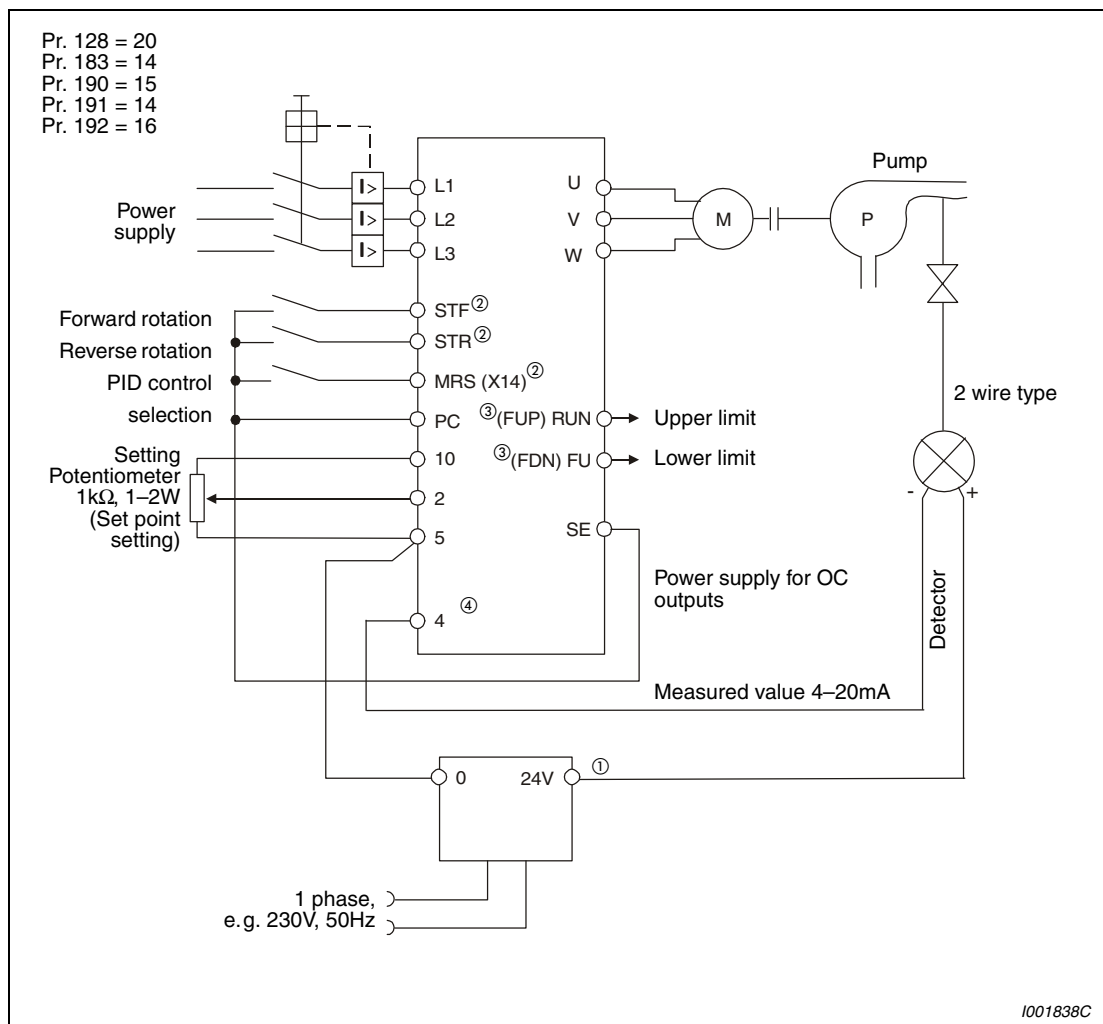

Fig. 6-138: Connection diagram in source logic

- ① The power supply must be selected in accordance with the power specifications of the detector used.
- ② The used input signal terminal changes depending on the Pr. 178 to Pr. 184 "Input terminal selection" setting.
- ③ The used output signal terminal changes depending on the Pr. 190 to Pr. 192 "Output terminal selection" setting.
- ④ The AU signal need not be input.

I/O signals and parameter setting

- ① Set "20, 21, 50, 51, 60 or 61" in Pr. 128 to perform PID operation.
- ② Set "14" in any of Pr. 178 to Pr. 184 "Input terminal function selection" to assign PID control selection signal (X14) to turn the X14 signal on.
When the X14 signal is not assigned, only the Pr. 128 setting makes PID control valid.
- ③ Enter the set point using the inverter terminal 2 or Pr. 133 and enter the measured value to terminal 4.

NOTES

When Pr. 128 = "0" or X14 signal is off, normal inverter operation is performed without PID action.

Turning ON/OFF of bit of the terminal, to which X14 signal is assigned through network as RS-485 communication, enables PID control.

| Signal | Terminal used | Function | Description | Parameter Setting | |
|---------------------------------|-----------------|--------------------------|--|--|--|
| Input | X14 | Depending on Pr. 178–184 | PID control selection | Turn on X14 to perform PID control. ① | Set "14" to any of Pr. 178 to Pr. 184. |
| | 2 | 2 | Set point input | Enter the set point for PID control. | Pr. 128 = 20, 21; Pr. 133 = 9999 |
| | | | | 0–5V..... 0–100% | Pr. 73 = 1 ②, 11 |
| | | | | 0–10V..... 0–100% | Pr. 73 = 0, 10 |
| | PU | — | Set point input | Set the set value (Pr. 133) from the operation panel. | Pr. 128 = 20, 21; Pr. 133 = 0–100% ⑤ |
| | 4 | 4 | Measured value input | Input the signal from the detector (measured value signal). | Pr. 128 = 20, 21 |
| | | | | 4–20mA..... 0–100% | Pr. 267 = 0 ② |
| | | | | 0–5V..... 0–100% | Pr. 267 = 1 |
| | | | | 0–10V..... 0–100% | Pr. 267 = 2 |
| | Communication ③ | — | Deviation value input | Input the deviation value from LONWORKS , CC-Link communication. | Pr. 128 = 50, 51 |
| Set value, measured value input | | | Input the set value and measured value from LONWORKS , CC-Link communication | Pr. 128 = 60, 61 | |

Tab. 6-103: I/O signals and parameter settings (1)

| | Signal | Terminal used | Function | Description | Parameter Setting |
|--------|--------|--------------------------|---|--|--|
| Output | FUP | Depending on Pr. 190–192 | Upper limit output | Output to indicate that the measured value signal exceeded the upper limit value (Pr. 131). | Pr. 128 = 20, 21, 60, 61 Pr. 131 ≠ 9999 Set "15" or "115" to any of Pr. 190–Pr. 192. ④ |
| | FDN | | Lower limit output | Output when the measured value signal falls below the lower limit (Pr.132). | Pr. 128 = 20, 21, 60, 61 Pr. 132 ≠ 9999 Set "14" or "114" to any of Pr. 190–Pr. 192. ④ |
| | RL | | Forward (reverse) rotation direction output | "Hi" is output to indicate that the output indication of the parameter unit is forward rotation (FWD) or "Low" to indicate that it is reverse rotation (REV) or stop (STOP). | Set "16" or "116" to any of Pr. 190–Pr. 192. ④ |
| | PID | | During PID control activated | Turns on during PID control. | Set "47" or "147" to any of Pr. 190–Pr. 192. ④ |
| | SE | SE | Output terminal common | Common terminal for open collector output terminal. | |

Tab. 6-103: I/O signals and parameter settings (2)

- ① When the X14 signal is not assigned, only the Pr. 128 setting makes PID control valid.
- ② The half-tone screened areas indicate the parameter initial values.
- ③ Refer to the CC-Link communication option (FR-A7NC E kit) instruction manual for the setting method from CC-Link communication.
Refer to the LONWORKS communication option (FR-A7NL E kit) instruction manual for the setting method from LONWORKS communication.
- ④ When "100" or larger value is set to any of Pr. 190 to Pr. 192 "Output terminal function selection", the terminal output has negative logic. (Refer to section 6.10.5 for details.)
- ⑤ If Pr. 133 is used for the set point signal (setting ≠ 9999) any additional set point signal applied to terminals 2-5 will be ignored.

NOTES

Changing the terminal function using any of Pr. 178 to Pr. 184 and Pr. 190 to Pr. 192 may affect the other functions. Make setting after confirming the function of each terminal.

When the Pr. 267 setting was changed, check the voltage/current input switch setting. Different setting may cause a fault, failure or malfunction. (Refer to page 6-175 for setting.)

PID control automatic switchover control (Pr. 127)

For a fast system start-up at an operation start, the system can be started up in normal operation mode only at a start.

When the frequency is set to Pr. 127 "PID control automatic switchover frequency" within the range 0 to 400Hz, the system starts up in normal operation mode from a start until Pr. 127 is reached, and then it shifts to PID control operation mode. Once the system has entered PID control operation, it continues PID control if the output frequency falls to or below Pr. 127.

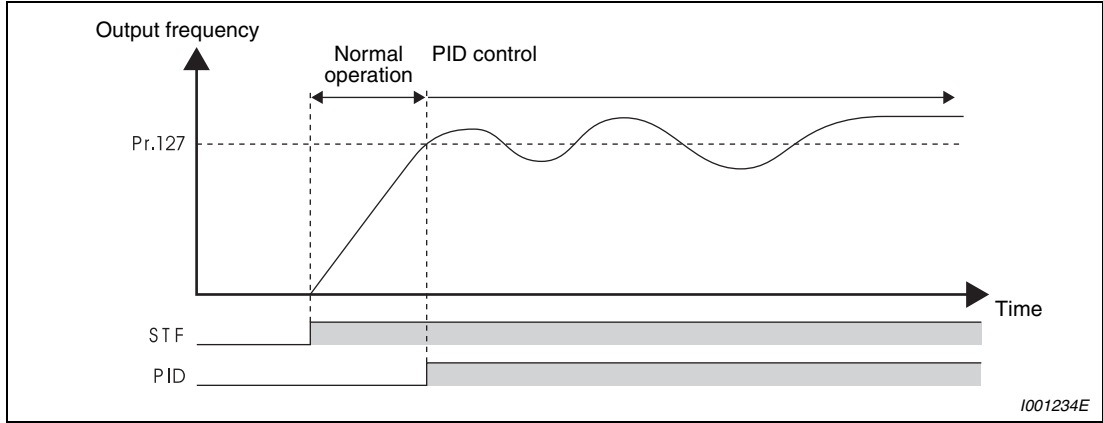

Fig. 6-139: Automatic switchover to PID control

PID monitor function

The PID control set point, measured value and deviation value can be displayed on the operation panel and output from terminal AM.

The deviation monitor displays a negative value on the assumption that 1000 is 0%. (The deviation monitor cannot be output from the terminal AM.)

For each monitor, set the following value in Pr. 52 "DU/PU main display data selection" and Pr. 158 "AM terminal function selection".

| Setting | Monitor Description | Minimum Increment | Terminal AM Full Scale | Remarks |
|---------|-----------------------|-------------------|------------------------|--|
| 52 | PID set point | 0.1% | 100% | — |
| 53 | PID measurement value | 0.1% | 100% | |
| 54 | PID deviation value | 0.1% | — | Value cannot be output from the terminal AM. The PID deviation value of 0% is displayed as 1000. |

Tab. 6-104: PID monitor function

Adjustment procedure

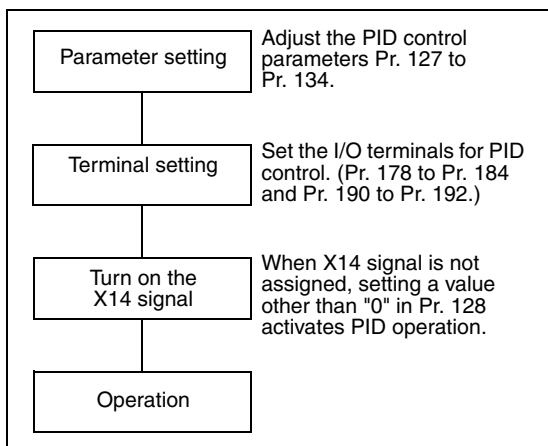

Fig. 6-140: Adjustment procedure

Calibration example

Example ▾

A detector of 4mA at 0°C and 20mA at 50°C is used to adjust the room temperature to 25°C under PID control. The set point is given to across inverter terminals 2-5 (0 to 5V).

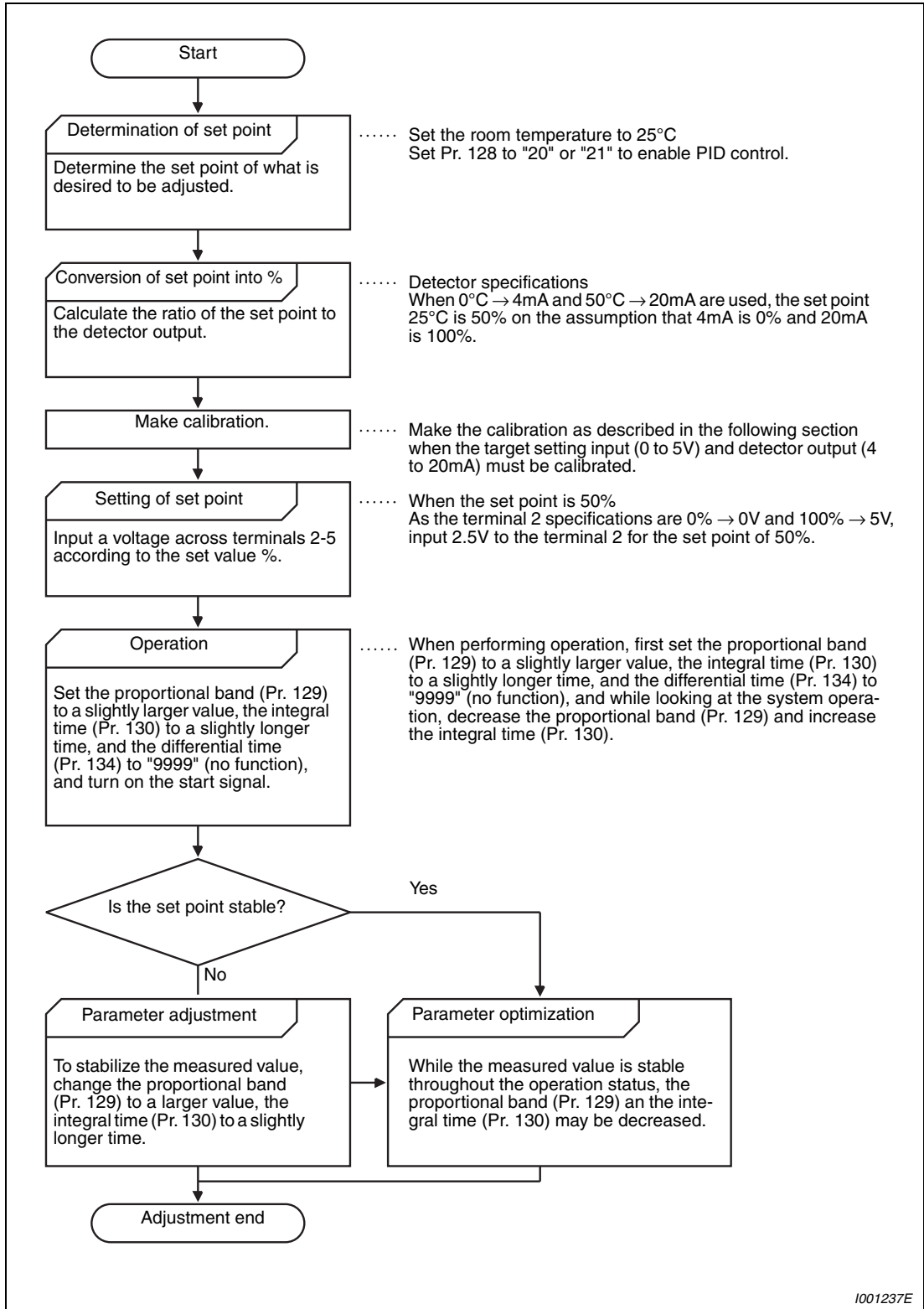

Fig. 6-141: Calibration example

Set point input calibration

- ① Apply the input voltage of 0% set point setting (e.g. 0V) across terminals 2-5.
- ② Enter in C2 (Pr. 902) the frequency which should be output by the inverter at the deviation of 0% (e.g. 0Hz).
- ③ In C3 (Pr. 902), set the voltage value at 0%.
- ④ Apply the voltage of 100% set point (e.g. 5V) to across terminals 2-5.
- ⑤ Enter in Pr. 125 the frequency which should be output by the inverter at the deviation of 100% (e.g. 50Hz).
- ⑥ In C4 (Pr. 903), set the voltage value at 100%.

Process value input calibration

- ① Apply the input current of 0% detector setting (e.g. 4mA) across terminals 4-5.
- ② Make calibration of the process value bias (%) using C6 (Pr. 904).
- ③ Apply the input current of 100% detector setting (e.g. 20mA) across terminals 4-5.
- ④ Make calibration of the process value gain (%) using C7 (Pr. 905).

NOTE

The frequency set in C5 (Pr. 904) and Pr. 126 should be the same as set in C2 (Pr. 902) and Pr. 125.

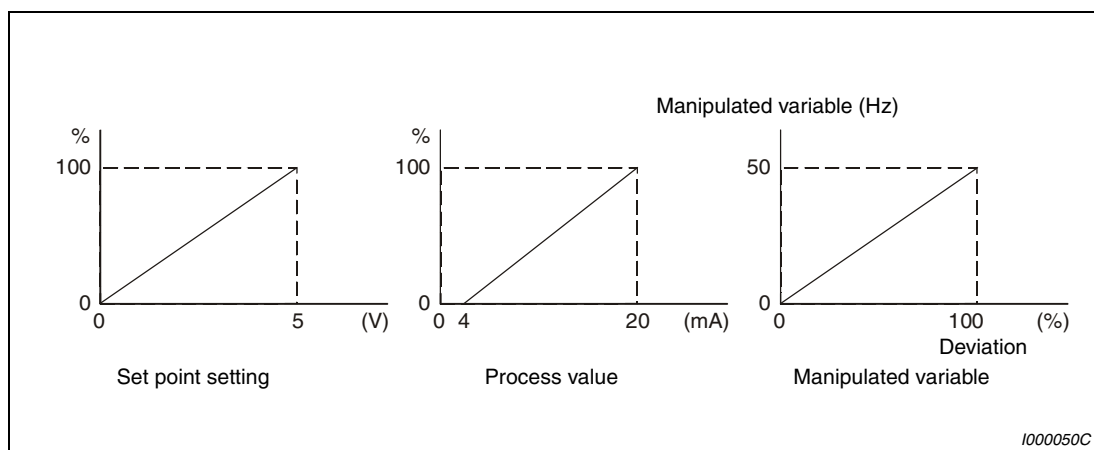

Fig. 6-142: Input calibration

NOTES

If the multi-speed (RH, RM, RL signal) or jog operation (jog signal) is entered with the X14 signal on, PID control is stopped and multi-speed or jog operation is started.

If the setting is as follows, PID control becomes invalid. Pr. 79 "Operation mode selection" = 6 (switchover mode). When the inverter is at a stop with Pr. 261 "Power failure stop selection" selected.

Changing the terminal function using any of Pr. 178 to Pr. 184, Pr. 190 to Pr. 192 may affect the other functions. Make setting after confirming the function of each terminal.

When PID control is selected, the minimum frequency is the frequency set in Pr. 902 and the maximum frequency is the frequency set in Pr. 903. (Pr. 1 "Maximum frequency" and Pr. 2 "Minimum frequency" settings are also valid.)

The remote operation function is invalid during PID operation.

When the control is switched to PID control during normal operation, the frequency command value calculated by PID operation using 0Hz as standard is used without the frequency during the operation.

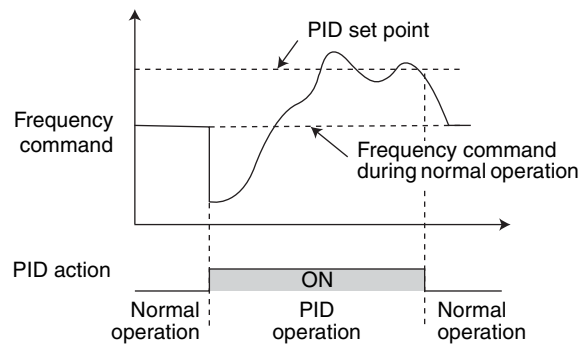

Operation when control is switched to PID control during normal operation

6.20.2 Dancer control (Pr. 44, Pr. 45, Pr. 128 to Pr. 134)

Performs PID control by feedbacking the position detection of the dancer roller, controlling the dancer roller is in the specified position.

| Pr. No. | Name | Initial Value | Setting Range | Description | Parameters referred to | Refer to Section | | |
|---------|---------------------------------------|---|-------------------------|--|---|--------------------------------|---|---|
| 44 | Second acceleration/deceleration time | FR-E720S-110 or less FR-E740-095 or less | 5s | 0–3600/ 360s | This parameter is the acceleration time of the main speed during dancer control. It will not function as second acceleration/deceleration time. | | | |
| | | FR-E740-120 and 170 | 10s | | | | | |
| | | FR-E740-230 and 300 | 15s | | | | | |
| 45 | Second deceleration time | 9999 | 0–3600/ 360s 9999 | This parameter is the deceleration time of the main speed during dancer control. It will not function as second deceleration time. | | | | |
| 128 | PID action selection | 0 | 0 | PID action is not performed | | C2 (Pr. 902) – C7 (Pr. 905) | 6.6.3 6.16.1 6.18.1 6.10.1 6.10.5 6.16.3 | |
| | | | 20 | PID reverse action | Measured value (terminal 4) Set value (terminal 2 or Pr. 133) | | | |
| | | | 21 | PID forward action | | | | |
| | | | 40 | PID reverse action | Addition method: fixed | | | For dancer control set point (Pr. 133), measured value (terminal 4) main speed (speed command of the operation mode) |
| | | | 41 | PID forward action | | | | |
| | | | 42 | PID reverse action | Addition method: ratio | | | |
| | | | 43 | PID forward action | | | | |
| | | | 50 | PID reverse action | Deviation value signal input (LONWORKS, CC-Link communication) | | | |
| | | | 51 | PID forward action | | | | |
| | | | 60 | PID reverse action | Set point and measured value input (LONWORKS, CC-Link communication) | | | |
| 61 | PID forward action | | | | | | | |
| 129 | PID proportional band ① | 100% | 0.1 – 1000% | If the proportional band is narrow (parameter setting is small), the manipulated variable varies greatly with a slight change of the measured value. Hence, as the proportional band narrows, the response sensitivity (gain) improves but the stability deteriorates, e.g. hunting occurs. Gain $K_p = 1/\text{proportional band}$ | | | | |
| | | | 9999 | No proportional control | | | | |
| 130 | PID integral time ① | 1s | 0.1 – 3600s | For deviation step input, time (T_i) required for only the integral (I) action to provide the same manipulated variable as that for the proportional (P) action. As the integral time decreases, the set point is reached earlier but hunting occurs more easily. | | | | |
| | | | 9999 | No integral control. | | | | |
| 131 | PID upper limit | 9999 | 0–100% | Maximum value If the feedback value exceeds the setting, the FUP signal is output. The maximum input (20mA/5V/10V) of the measured value (terminal 4) is equivalent to 100%. | | | | |
| | | | 9999 | No function | | | | |
| 132 | PID lower limit | 9999 | 0–100% | Minimum value If the process value falls below the setting range, the FDN signal is output. The maximum input (20mA/5V/10V) of the measured value (terminal 4) is equivalent to 100%. | | | | |
| | | | 9999 | No function | | | | |
| 133 | PID action set point ① | 9999 | 0–100% | Used to set the set point for PID control. | | | | |
| | | | 9999 | Always 50% | | | | |
| 134 | PID differential time ① | 9999 | 0.01 – 10.00s | For deviation ramp input, time (T_d) required for providing only the manipulated variable for the proportional (P) action. As the differential time increases, greater response is made to a deviation change. | | | | |
| | | | 9999 | No differential control. | | | | |

The above parameters can be set when Pr.160 "User group read selection" = 0.

① Pr.129, Pr.130, Pr.133 and Pr.134 can be set during operation. They can also be set independently of the operation mode.

Dancer control block diagram

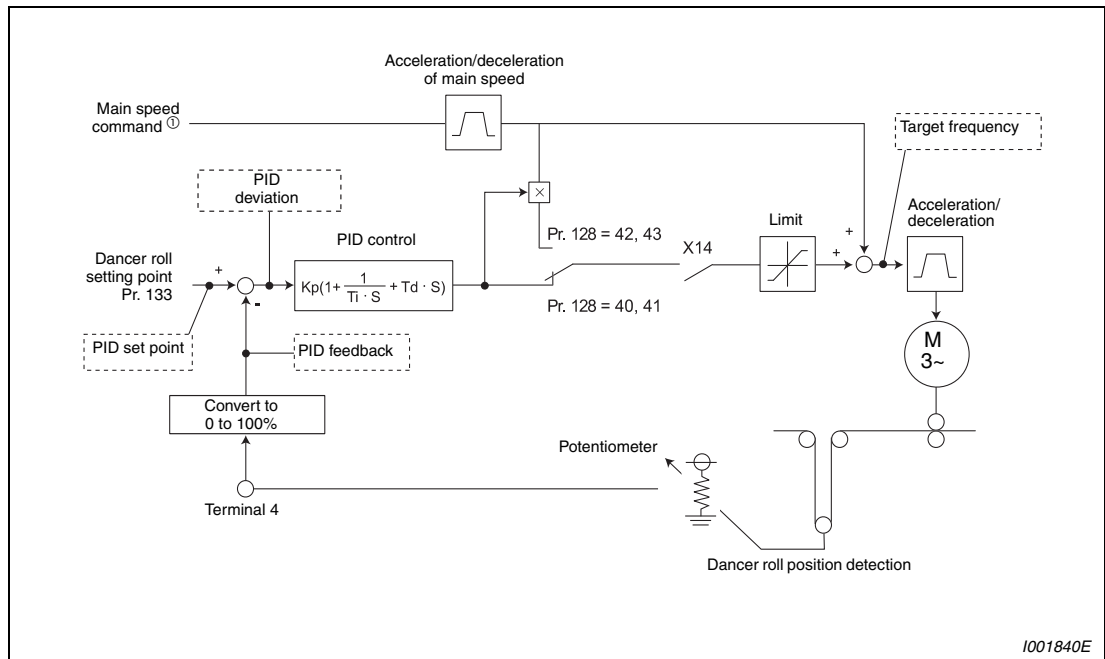

Fig. 6-143: Dancer control block diagram

① The main speed can be selected from all operation mode such as external (analog voltage input, multi-speed), PU (digital frequency setting), communication (RS-485, CC-Link).

Set point and measured value of PID control

| | Input | Input Signal | Pr. 267 | Current/Voltage Input Switch |
|----------------|--|---------------------------|---------|------------------------------|
| Set point | Pr. 133 | 0-100% | — | — |
| Measured value | When measured value is input as current (4 to 20mA). | 4mA ... 0%, 20mA ... 100% | 0 | |
| | | 0V ... 0%, 5V ... 100% | 1 | |
| | | 0V ... 0%, 10V ... 100% | 2 | |

Tab. 6-105: Set point and measured value of PID control

NOTES

Changing the terminal function using any of Pr.178 to Pr.184 may affect the other functions. Make setting after confirming the function of each terminal.

When the Pr. 267 setting was changed, check the voltage/current input switch setting. Different setting may cause a fault, failure or malfunction. (Refer to page 6-175 for setting.)

Dancer control overview

Performs dancer control by setting 40 to 43 in Pr. 128 "PID action selection". The main speed command is the speed command of each operation mode (external, PU, Network). Performs PID control by the position detection signal of the dancer roller, then the result is added to the main speed command. For acceleration/deceleration of the main speed, set the acceleration time in Pr. 44 "Second acceleration/deceleration time" and the deceleration time in Pr. 45 "Second deceleration time".

Set 0s normally to Pr.7 "Acceleration time" and Pr.8 "Deceleration time". When the Pr. 7 and Pr. 8 setting is large, response of dancer control during acceleration/deceleration is slow.

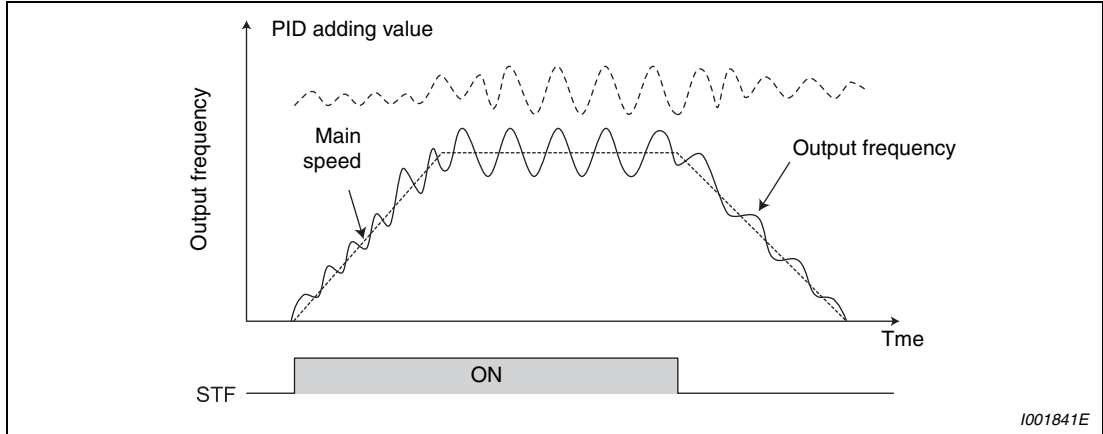

Fig. 6-144: Signal overlay during dancer control

Connection diagram

The following figure shows a typical application example:

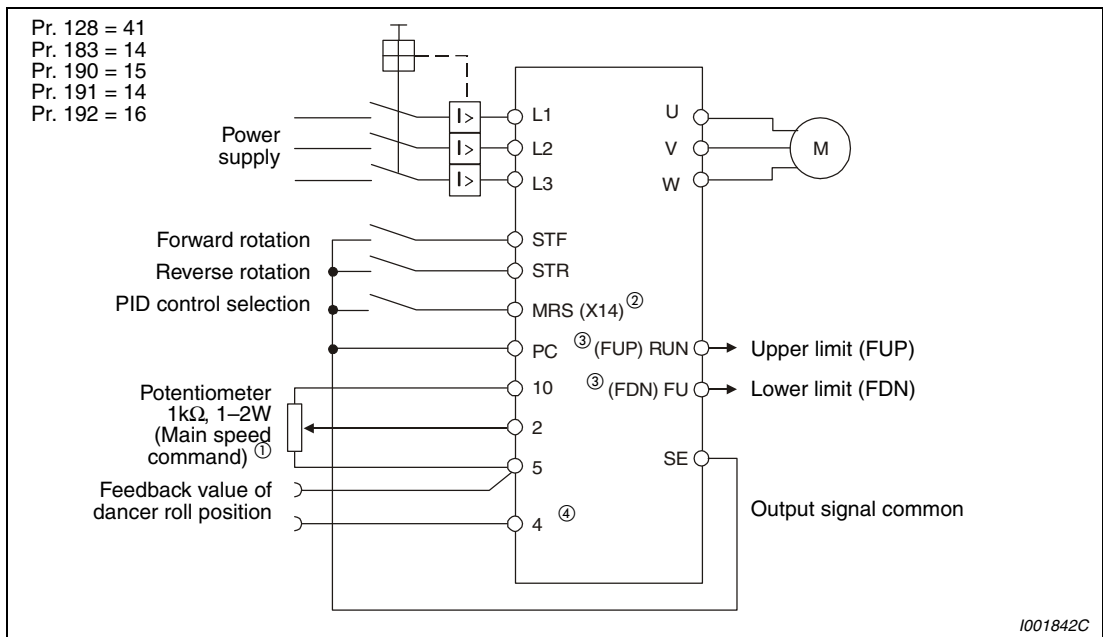

Fig. 6-145: Example in source logic

- ① The main speed command differs according to each operation mode (external, PU, communication).
- ② The used output signal terminal changes depending on the Pr. 190 to Pr. 192 "Output terminal selection" setting.
- ③ The used input signal terminal changes depending on the Pr. 178 to Pr. 184 "Input terminal selection" setting.
- ④ The AU signal need not be input.

I/O signals and parameter setting

- ① Set "40 to 43" in Pr. 128 to perform dancer control.
- ② Set "14" in any of Pr. 178 to Pr. 184 "Input terminal function selection" to assign PID control selection signal (X14) to turn the X14 signal on.
When the X14 signal is not assigned, only the Pr. 128 setting makes dancer control valid.
- ③ Input the set point using Pr. 133, then input the measured value signal (dancer roller position detection signal) across terminal 4 and 5 of the inverter.

NOTES

When Pr. 128 = "0" or X14 signal is off, normal inverter operation is performed without dancer control.

Turning ON/OFF of bit of the terminal, to which X14 signal is assigned through network as RS-485 communication, enables dancer control.

| | Signal | Terminal used | Function | Description | Parameter Setting |
|--------|--------------------|--------------------------|---|---|--|
| Input | X14 | Depending on Pr. 178–184 | PID control selection | Turn on X14 signal to perform dancer control. ① | Set "14" in any of Pr. 178 to Pr. 184. |
| | 4 | 4 | Measured value input | Input the signal from the dancer roller detector (measured value signal). | Pr. 128 = 40, 41, 42, 43 |
| | | | | 4–20mA 0–100% | Pr. 267 = 0 ② |
| | | | | 0–5V 0–100% | Pr. 267 = 1 |
| | 0–10V 0–100% | Pr. 267 = 2 | | | |
| Output | FUP | Depending on Pr. 190–192 | Upper limit output | Output to indicate that the measured value signal exceeded the maximum value (Pr. 131). | Pr. 128 = 40, 41, 42, 43 Pr. 131 ≠ 9999 Set "15" or "115" in any of Pr. 190 to Pr.192. ③ |
| | FDN | | Lower limit output | Output when the measured value signal falls below the minimum value (Pr. 132). | Pr. 128 = 40, 41, 42, 43 Pr. 132 ≠ 9999 Set "14" or "114" in any of Pr. 190 to Pr.192. ③ |
| | RL | | Forward (reverse) rotation direction output | Output is "ON" when the output indication of the parameter unit is forward rotation (FWD) and "OFF" when reverse rotation (REV) or stop (STOP). | Set "16" or "116" in any of Pr. 190 to Pr. 192. ③ |
| | PID | | During PID control activated | Turns on during PID control. | Set "47" or "147" in any of Pr. 190 to Pr. 192. ③ |
| | SE | SE | Output terminal common | Common terminal for open collector output terminal. | |

Tab. 6-106: I/O signals and parameter setting

- ① When the X14 signal is not assigned, only the Pr. 128 setting makes dancer control valid.
- ② The half-tone screened areas indicate the parameter initial values.
- ③ When 100 or larger value is set in any of Pr. 190 to Pr. 192 "Output terminal function selection", the terminal output has negative logic. (For details, refer to section 6.10.5.)

NOTES

Changing the terminal function using any of Pr. 178 to Pr. 184 and Pr. 190 to Pr. 192 may affect the other functions. Make setting after confirming the function of each terminal.

When the Pr. 267 setting was changed, check the voltage/current input switch setting. Different setting may cause a fault, failure or malfunction. (Refer to page 6-175 for setting.)

Parameter details

When ratio (Pr. 128 = 42, 43) is selected for addition method, PID control \times (ratio of main speed) is added to the main speed. The ratio is determined by the Pr. 125 "Terminal 2 frequency setting gain frequency" and C2 (Pr. 902) "Terminal 2 frequency setting bias frequency". The frequency setting signal is set to 0 to 50Hz in the range between 0 to 100% in the initial setting. The ratio is ($\times 100\%$) when the main speed is 50Hz and ($\times 50\%$) when 25Hz.

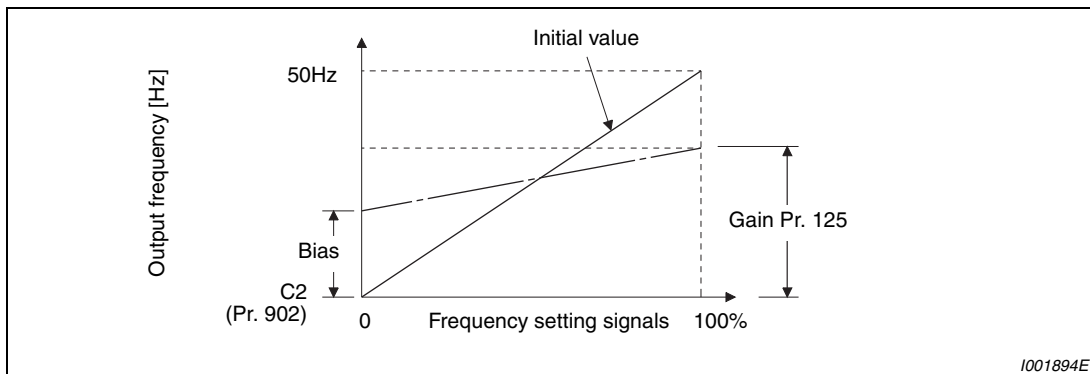

Fig. 6-146: Signal calibration at terminal 2

NOTES

Even when C4 (Pr. 903) is set to other than 100%, the frequency setting signal is considered as 100%.

Even when C3 (Pr. 903) is set to other than 0%, the frequency setting signal is considered as 0%.

When C2 (Pr. 902) is set to other than 0Hz, the frequency setting signal is 0% when C2 (Pr. 902) is less than the set frequency.

Turning X14 signal on/off during operation by assigning X14 signal results in the following operation.

When X14 signal is on: Uses output frequency unchanged as the main speed command and continues operation by dancer control.

When X14 signal is off: Ends dancer control and continues operation at the set frequency made valid.

| Pr. 128 | PID Action | Addition Method | Set Point | Measured Value | Main Speed Command |
|---------|----------------|-----------------|-----------|----------------|---------------------------------------|
| 40 | Reverse action | Fixed | Pr. 133 | Terminal 4 | Speed command for each operation mode |
| 41 | Forward action | | | | |
| 42 | Reverse action | Ratio | | | |
| 43 | Forward action | | | | |

Tab. 6-107: PID control in dependence of parameter 128

Action of Pr. 129 "PID proportional band", Pr. 130 "PID integral time", Pr. 131 "PID upper limit", Pr. 132 "PID lower limit", Pr. 134 "PID differential time is the same as PID control. For the relationship of controlled variable (%) of PID control and frequency, 0% is equivalent to the set frequency of Pr. 902 and 100% to Pr. 903.

For the Pr. 133 "PID action set point" setting, set frequency of Pr. 902 is equivalent to 0% and Pr. 903 to 100%. When 9999 is set in Pr. 133, 50% is the set point.

NOTE

Pr. 127 "PID control automatic switchover frequency" is invalid.

Output signal

Output terminal assignment during dancer control (PID control) operation
 PID signal turns on during dancer control (PID control) or at a stop by PID control (in the status PID operation being performed inside) (The signal is off during normal operation.)

For the terminal used for PID signal output, assign the function by setting "47 (positive logic) or 147 (negative logic)" in any of Pr. 190 to Pr. 192 "Output terminal function selection".

NOTE

Changing the terminal function using any of Pr. 178 to Pr. 184, Pr. 190 to Pr. 192 may affect the other functions. Make setting after confirming the function of each terminal.

PID monitor function

The PID control set point and measured value can be output to the operation panel monitor display and terminal AM.

For each monitor, set the following value in Pr. 52 "DU/PU main display data selection" and Pr. 158 "AM terminal function selection".

| Setting | Monitor Description | Minimum Increments | Terminal AM Full Scale | Remarks |
|---------|---------------------|--------------------|------------------------|--|
| 52 | PID set point | 0.1% | 100% | — |
| 53 | PID measured value | 0.1% | 100% | |
| 54 | PID deviation value | 0.1% | — | Value cannot be output from the terminal AM. The PID deviation value of 0% is displayed as 1000. |

Tab. 6-108: PID monitor function

Priorities of main speed command

The priorities of the main speed speed command source when the speed command source is external are as follows.

JOG signal > multi-speed setting signal (RL/RM/RH/REX) > 16 bit digital input (option) > terminal 2

The priorities of the main speed speed command source when "3" is set in Pr. 79.

Multi-speed setting signal (RL/RM/RH/REX) > set frequency (digital setting by PU, operation panel)

Terminal 4 can not be selected as the main speed speed command even when AU terminal is turned on.

Even when a remote operation function is selected by setting a value other than "0" in Pr. 59, compensation of the remote setting frequency to the main speed is ignored (changes to 0).

Dancer roller position detection signal adjustment

When terminal 4 input is voltage input, 0V is minimum position and 5V (10V) is maximum position. When current is input, 4mA is minimum position and 20mA is maximum position (initial value). When 0 to 7V is output from the potentiometer, it is necessary to calibrate C7 (Pr. 905) at 7V.

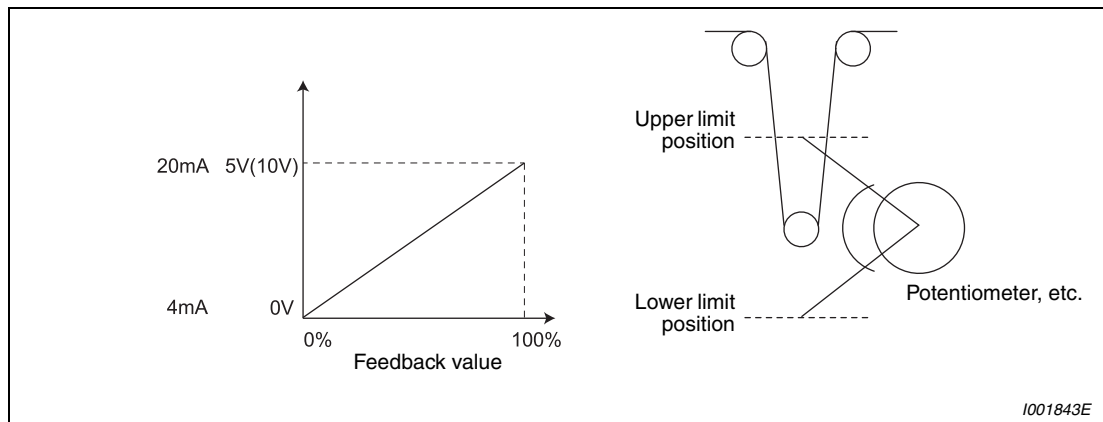

Fig. 6-147: Dancer roller position detection signal adjustment

Example ▽

Control at a dancer center position using a 0 to 7V potentiometer

- ① After changing the current/voltage input switch to "V", set "2" in Pr. 267 to change terminal 4 input to voltage input.
- ② Input 0V to across terminal 4 and 5 to calibrate C6 (Pr. 904). (% display displayed at analog calibration is irrelevant to % of the feed back value.)
- ③ By inputting 7V to across terminal 4 to 5, calibrate C7 (Pr. 905). (% display displayed at analog calibration is irrelevant to % of the feed back value.)
- ④ Set 50% in Pr.133.

NOTE

When the Pr. 267 setting was changed, check the voltage/current input switch setting. Different setting may cause a fault, failure or malfunction. (Refer to page 6-175 for setting.)

△

NOTES

In normal PID control, PID control is stopped when multi-speed operation signal (RH, RM, RL, REX signal) or JOG signal is input. In dancer control, however, PID control continues handling the signals as the main speed.

During dancer control, Second acceleration/deceleration time of Pr. 44 and Pr. 45 are the parameters for acceleration/deceleration time setting to the main speed command source. They do not function as the second function.

When switchover mode is set with "6" in Pr. 79 , dancer control (PID control) is invalid.

Speed command of terminal 4 input from terminal AU is invalid when dancer control is selected.

Acceleration/deceleration of the main speed command is the same operation as when frequency command is increased/decreased by analog input.

- Therefore, SU signal remains on even if the starting signal is turned on/off (always in the constant speed state).
- The DC brake operation starting frequency when turning off the starting signal is not Pr. 10 but a smaller value of either Pr. 13 or 0.5Hz.
- The set frequency monitor is always variable as "main speed command+PID control".

The main speed setting frequency accelerates for the acceleration/deceleration time set in Pr. 44 and Pr. 45 and the output frequency accelerates/decelerates for the acceleration/deceleration time set in Pr. 7 and Pr. 8. Therefore, when the set time of Pr. 7 and Pr. 8 is longer than Pr. 44 and Pr. 45, the output frequency accelerates/decelerates for the acceleration/deceleration time set in Pr. 7 and Pr. 8.

For the integral term limit, a smaller value of either the PID manipulated variable (%) value converted from the linear, interpolated Pr. 1 "Maximum frequency" with Pr. 902 and Pr. 903, or 100% is used for limit. Although the output frequency is limited by the minimum frequency, operation limit of the integral term is not performed.

6.20.3 Droop control (Pr. 286 to Pr. 287) AD MFVC

This function is designed to balance the load in proportion to the load torque to provide the speed drooping characteristic under advanced magnetic flux vector control. This function is effective for balancing the load when using multiple inverters.

| Pr. No. | Name | Initial Value | Setting Range | Description | Parameters referred to | Refer to Section |
|------------|----------------------------|---------------|---------------|--|---------------------------------|------------------|
| 286 | Droop gain | 0% | 0 | Droop control is invalid (Normal operation) | 1 Maximum frequency PID control | 6.4.1 6.20.1 |
| | | | 0.1–100% | Droop control is valid Drooping amount at the rated torque as a percentage with respect to the rated motor frequency. | | |
| 287 | Droop filter time constant | 0.3s | 0–1s | Time constant of the filter applied on the torque current. | | |

The output frequency is changed according to the magnitude of torque current under advanced magnetic flux vector control. The drooping amount at the rated torque is set by the droop gain as a percentage using the rated frequency as a reference.

The maximum droop compensation frequency is 120Hz.

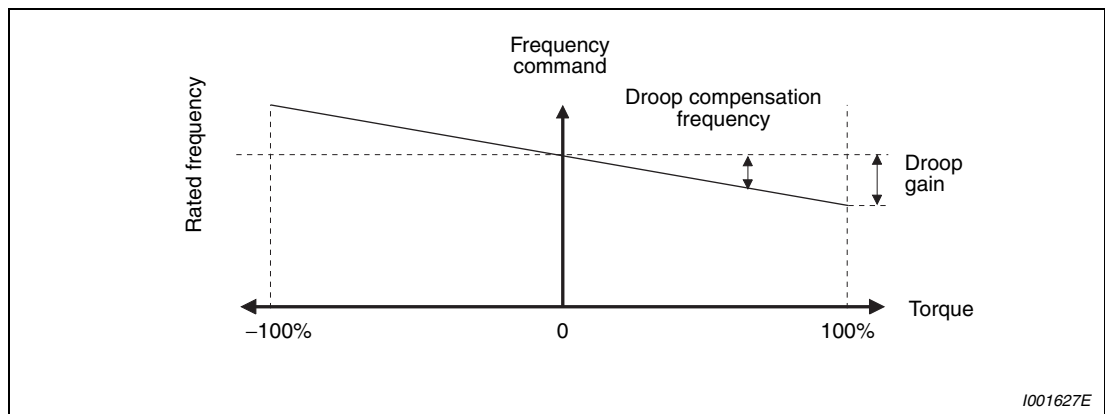

Fig. 6-148: Droop control

$$\text{Droop compensation frequency} = \frac{\text{Torque current after filtering}}{\text{Rated value of base frequency}} \times \frac{\text{Rated motor frequency} \times \text{Droop gain}}{100}$$

NOTES

Set the droop gain to about the rated slip of the motor.

$$\text{Rated slip} = \frac{\text{Synchronous speed at base frequency} - \text{Rated speed}}{\text{Synchronous speed at base frequency}} \times 100 [\%]$$

Droop control is invalid during PID control operation.

The maximum value of frequency after droop compensation is either 120Hz or Pr. 1 "Maximum frequency", whichever is smaller.

6.20.4 Regeneration avoidance function (Pr. 665, Pr. 882, Pr. 883, Pr. 885, Pr. 886)

This function detects a regeneration status and increases the frequency to avoid the regeneration status.

Possible to avoid regeneration by automatically increasing the frequency and continue operation if the fan happens to rotate faster than the set speed due to the effect of another fan in the same duct.

| Pr. No. | Name | Initial Value | | Setting Range | Description | Parameters referred to | Refer to Section |
|---------|---|---------------|------|---------------|---|---|-------------------------|
| 882 | Regeneration avoidance operation selection | 0 | | 0 | Regeneration avoidance function invalid | 1 Maximum frequency 8 Deceleration time 22 Stall prevention operation level | 6.4.1 6.7.1 6.3.5 |
| | | | | 1 | Regeneration avoidance function is always valid | | |
| | | | | 2 | Regeneration avoidance function is valid only during a constant speed operation | | |
| 883 | Regeneration avoidance operation level | 200V class | 400V | 300–800V | Set the bus voltage level at which regeneration avoidance operates. When the bus voltage level is set to low, over voltage error will be less apt to occur. However, the actual deceleration time increases. The set value must be higher than the power supply voltage $\times \sqrt{2}$. | | |
| | | 400V class | 780V | | | | |
| 885 | Regeneration avoidance compensation frequency limit value | 6 Hz | | 0–10Hz | Set the limit value of frequency which rises at activation of regeneration avoidance function. | | |
| | | | | 9999 | Frequency limit invalid | | |
| 886 | Regeneration avoidance voltage gain | 100% | | 0–200% | Responsiveness at activation of regeneration avoidance. A larger setting will improve responsiveness to the bus voltage change. However, the output frequency could become unstable. When vibration is not suppressed by decreasing the Pr. 886 setting, set a smaller value in Pr. 665. | | |
| 665 | Regeneration avoidance frequency gain | 100% | | 0–200% | | | |

The above parameters can be set when Pr. 160 "User group read selection" = 0.

What is regeneration avoidance function? (Pr. 882, Pr. 883)

When the regeneration status is serious, the DC bus voltage rises and an over voltage alarm (E.OV□) may occur. When this bus voltage rise is detected and the bus voltage level reaches or exceeds Pr. 883, increasing the frequency avoids the regeneration status.

The regeneration avoidance function is always on when "1" is set in Pr. 882 and activated only during a constant speed when "2" is set in Pr. 882.

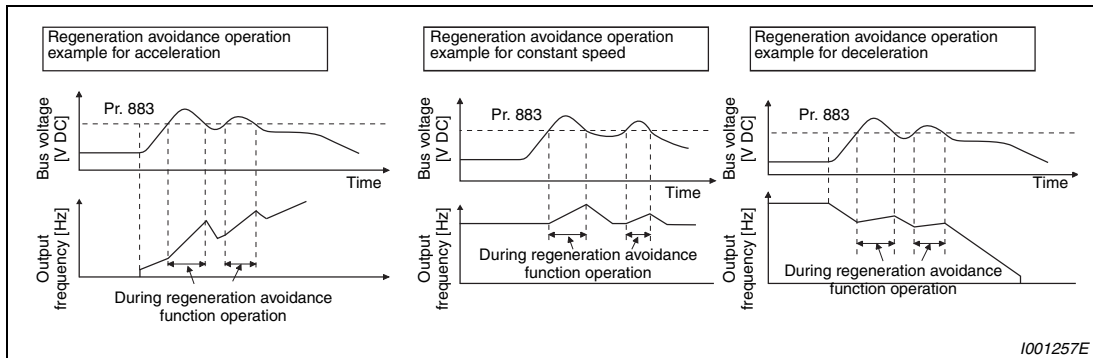

Fig. 6-149: Regeneration avoidance function

NOTES

The inclination of the frequency increased or decreased by the regeneration avoidance function changes depending on the regeneration status.

The DC bus voltage of the inverter is normally about $\sqrt{2}$ times greater than the input voltage (when the input voltage is 220 V, the bus voltage is about 311 V DC and when the input voltage is 440V AC, the bus voltage is about 622V DC). However, it varies with the input power supply waveform.

The Pr. 883 setting should be kept higher than the DC bus voltage level. Otherwise, the regeneration avoidance function is always on.

While over voltage stall (oL) stops the output frequency during deceleration, the regeneration avoidance function is always on and increases the frequency according to the regeneration amount.

Limit regeneration avoidance operation frequency (Pr. 885)

You can limit the output frequency compensated for (increased) by the regeneration avoidance function.

The frequency is limited to the output frequency (frequency prior to regeneration avoidance operation) + Pr. 885 "Regeneration avoidance compensation frequency limit value" during acceleration or constant speed. If the regeneration avoidance frequency exceeds the limit value during deceleration, the limit value is held until the output frequency falls to 1/2 of Pr. 885.

When the regeneration avoidance frequency has reached Pr. 1 "Maximum frequency", it is limited to the maximum frequency.

When Pr. 885 is set to "9999", the frequency setting is invalid.

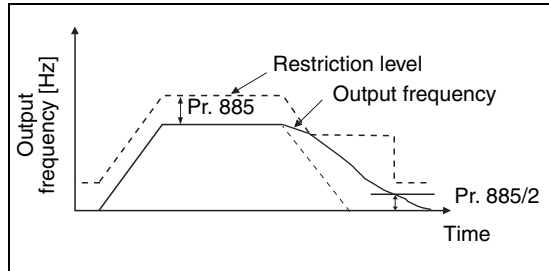

Fig. 6-150:
Limit the output frequency

1001260E

Regeneration avoidance function adjustment (Pr. 665, Pr. 886)

If the frequency becomes instable during regeneration avoidance operation, decrease the setting of Pr. 886 "Regeneration avoidance voltage gain". Reversely, if sudden regeneration causes an overvoltage alarm, increase the setting.

When vibration is not suppressed by decreasing the Pr. 886 setting, set a smaller value in Pr. 665 "Regeneration avoidance frequency gain".

NOTES

When regeneration avoidance operation is performed, "oL" (over voltage stall) is displayed and the OL signal is output.

When regeneration avoidance operation is performed, stall prevention is also activated at the same time.

The regeneration avoidance function cannot shorten the actual deceleration time taken to stop the motor. The actual deceleration time depends on the regeneration energy consumption capability. When shortening the deceleration time, consider using the regeneration unit (FR-BU2, FR-CV, FR-HC) and brake resistor (MRS, FR-ABR etc.) to consume regeneration energy at constant speed.

When using the regeneration unit (FR-BU2, FR-CV, FR-HC) and brake resistor (FR-ABR etc.), set Pr. 882 to "0 (initial value)" (regeneration avoidance function invalid). When using the regeneration unit, etc. to consume regeneration energy at deceleration, set Pr. 882 to "2" (regeneration avoidance function valid only at a constant speed).

When regeneration avoidance operation is performed, the OL signal output item of Pr. 156 also becomes the target of oL (over voltage stall). Pr. 157 "OL signal output timer" also becomes the target of (over voltage stall).

6.21 Useful functions

| Increase cooling fan life | Parameters that must be set | | Refer to Section |
|---|--------------------------------------|-----------------|------------------|
| To determine the maintenance time of parts. | Cooling fan operation selection | Pr. 244 | 6.21.1 |
| | Inverter part life display | Pr. 255–Pr. 259 | 6.21.2 |
| | Maintenance output function | Pr. 503–Pr. 504 | 6.21.3 |
| Freely available parameter | Current average value monitor signal | Pr. 555–Pr. 557 | 6.21.4 |
| Increase cooling fan life | Free parameter | Pr. 888–Pr. 889 | 6.21.5 |

6.21.1 Cooling fan operation selection (Pr. 244)

You can control the operation of the cooling fan (FR-E740-040 or more, FR-E720S-050 or more) built in the inverter.

| Pr. No. | Name | Initial Value | Setting Range | Description | Parameters referred to | Refer to Section |
|------------|---------------------------------|---------------|---------------|---|--|------------------|
| 244 | Cooling fan operation selection | 1 | 0 | Operates at power on Cooling fan on/off control invalid (The cooling fan is always on at power on) | 190–192 Output terminal function selection | 6.10.5 |
| | | | 1 | Cooling fan on/off control valid The fan is always on while the inverter is running. During a stop, the inverter status is monitored and the fan switches on-off according to the temperature of the heatsink. | | |

The above parameter can be set when Pr. 160 "User group read selection" = 0.

In either of the following cases, fan operation is regarded as faulty, "FN" is shown on the operation panel, and the fan fault "FAN" and alarm "LF" signals are output.

Pr. 244 = 0

When the fan comes to a stop with power on.

Pr. 244 = 1

When the fan stops during the fan ON command while the inverter is running.

For the terminal used for FAN signal output, set "25" (source logic) or "125" (sink logic) to any of Pr. 190 to Pr.192 "Output terminal function selection", and for the LF signal, set "98" (source logic) or "198" (sink logic).

NOTE

When terminal assignment is changed using Pr. 190 to Pr. 192 "Output terminal function selection", the other functions may be affected. Please make setting after confirming the function of each terminal.

6.21.2 Display of the life of the inverter parts (Pr. 255 to Pr. 259)

Degrees of deterioration of main circuit capacitor, control circuit capacitor, cooling fan and inrush current limit circuit and can be diagnosed by monitor.

When any part has approached the end of its life, an alarm can be output by self diagnosis to prevent a fault. (Use the life check of this function as a guideline since the life except the main circuit capacitor is calculated theoretically.) For the life check of the main circuit capacitor, the alarm signal (Y90) will not be output if a measuring method shown on page 6-298 is not performed.

| Pr. No. | Name | Initial Value | Setting Range | Description | Parameters referred to | Refer to Section |
|------------|---|---------------|------------------|--|--|------------------|
| 255 | Life alarm status display | 0 | (0-15) | Display whether the control circuit capacitor, main circuit capacitor, cooling fan, and each parts of the inrush current limit circuit has reached the life alarm output level or not. Reading only | 190-192 Output terminal function selection | 6.10.5 |
| 256 | Inrush current limit circuit life display | 100% | (0-100%) | Display the deterioration degree of the inrush current limit circuit. Reading only | | |
| 257 | Control circuit capacitor life display | 100% | (0-100%) | Display the deterioration degree of the control circuit capacitor. Reading only | | |
| 258 | Main circuit capacitor life display | 100% | (0-100%) | Display the deterioration degree of the main circuit capacitor. Reading only The value measured by Pr. 259 is displayed. | | |
| 259 | Main circuit capacitor life measuring | 0 | 0/1 (2/3/8/9) | Setting "1" and switching the power supply off starts the measurement of the main circuit capacitor life (refer to the following pages). When the Pr. 259 value is "3" after powering on again, the measuring is completed. Read the deterioration degree in Pr. 258. | | |

The above parameters can be set when Pr. 160 "User group read selection" = 0.

Life alarm display and signal output (Y90 signal, Pr. 255)

Whether any of the control circuit capacitor, main circuit capacitor, cooling fan and inrush current limit circuit has reached the life alarm output level or not can be checked by Pr. 255 "Life alarm status display" and life alarm signal (Y90).

- ① Read the setting of parameter 255.

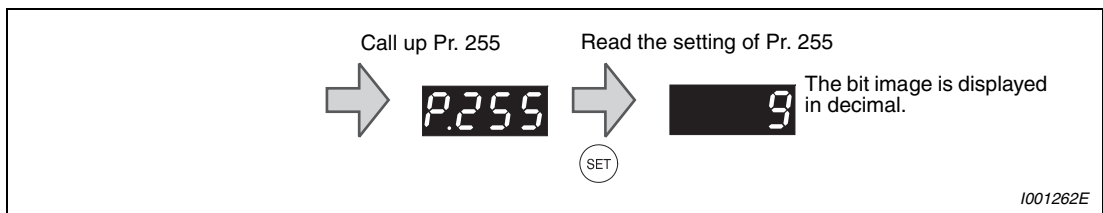

Fig. 6-151: Read parameter 255

- ② When the life alarm output level is reached, the bits are set as follows.

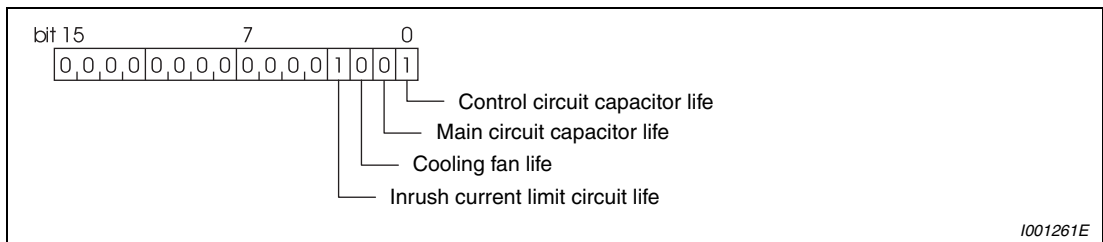

Fig. 6-152: Bits of parameter 255

| Pr. 255 (decimal) | Bits (binary) | Inrush Current Limit Circuit Life | Cooling Fan Life | Main Circuit Capacitor Life | Control Circuit Capacitor Life |
|----------------------|------------------|--------------------------------------|------------------|--------------------------------|-----------------------------------|
| 15 | 1111 | ✓ | ✓ | ✓ | ✓ |
| 14 | 1110 | ✓ | ✓ | ✓ | — |
| 13 | 1101 | ✓ | ✓ | — | ✓ |
| 12 | 1100 | ✓ | ✓ | — | — |
| 11 | 1011 | ✓ | — | ✓ | ✓ |
| 10 | 1010 | ✓ | — | ✓ | — |
| 9 | 1001 | ✓ | — | — | ✓ |
| 8 | 1000 | ✓ | — | — | — |
| 7 | 0111 | — | ✓ | ✓ | ✓ |
| 6 | 0110 | — | ✓ | ✓ | — |
| 5 | 0101 | — | ✓ | — | ✓ |
| 4 | 0100 | — | ✓ | — | — |
| 3 | 0011 | — | — | ✓ | ✓ |
| 2 | 0010 | — | — | ✓ | — |
| 1 | 0001 | — | — | — | ✓ |
| 0 | 0000 | — | — | — | — |

Tab. 6-109: Displaying the end of service life by bits

✓: End of the service life is reached

—: End of the service life is not reached

The life alarm signal (Y90) turns on when any of the control circuit capacitor, main circuit capacitor, cooling fan and inrush current limit circuit reaches the life alarm output level.

For the terminal used for the Y90 signal, set "90" (source logic) or "190" (sink logic) to any of Pr. 190 to Pr.192 "Output terminal function selection".

NOTE

When terminal assignment is changed using Pr. 190 to Pr. 192 "Output terminal function selection", the other functions may be affected. Please make setting after confirming the function of each terminal.

Life display of the inrush current limit circuit (Pr. 256)

The life of the inrush current limit circuit (relay, contactor and inrush resistor) is displayed in Pr. 259.

The number of contact (relay, contactor, thyristor) ON times is counted, and it is counted down from 100% (0 times) every 1%/10,000 times. As soon as 10% (900,000 times) is reached, Pr. 255 bit 3 is turned on and also an alarm is output to the Y90 signal.

Control circuit capacitor life display (Pr. 257)

The deterioration degree of the control circuit capacitor is displayed in Pr. 257 as a life.

In the operating status, the control circuit capacitor life is calculated from the energizing time and temperature of the inverter's heatsink, and is counted down from 100%. As soon as the control circuit capacitor life falls below 10%, Pr. 255 bit 0 is turned on and also an alarm is output to the Y90 signal.

Main circuit capacitor life display (Pr. 258, Pr. 259)

The deterioration degree of the main circuit capacitor is displayed in Pr. 258 as a life.

On the assumption that the main circuit capacitor capacitance at factory shipment is 100%, the capacitor life is displayed in Pr. 258 every time measurement is made. When the measured value falls to or below 85%, Pr. 255 bit 1 is turned on and also an alarm is output to the Y90 signal.

Measure the capacitor capacity according to the following procedure and check the deterioration level of the capacitor capacity.

- ① Check that the motor is connected and at a stop.
- ② Set "1" (measuring start) in Pr. 259.
- ③ Switch power off. The inverter applies DC voltage to the motor to measure the capacitor capacity while the inverter is off.
- ④ After confirming that the LED of the operation panel is off, power on again.
- ⑤ Check that "3" (measuring completion) is set in Pr. 259, read Pr 258, and check the deterioration degree of the main circuit capacitor.

| Pr. 259 | Description | Remarks |
|---------|--|---|
| 0 | No measurement | Initial value |
| 1 | Measurement start | Measurement starts when the power supply is switched off. |
| 2 | During measurement | Only displayed and cannot be set |
| 3 | Measurement complete | |
| 8 | Forced end (see ③, ⑦, ⑧, ⑨ below) | |
| 9 | Measurement error (see ④, ⑤, ⑥ below) | |

Tab. 6-110: Parameter 259

When the main circuit capacitor life is measured under the following conditions, "forced end" (Pr. 259 = 8) or "measuring error" (Pr. 259 = 9) occurs or it remains in "measuring start" (Pr. 259 = 1). Therefore, do not measure in such case. In addition, even when "measurement completion" (Pr. 259 = 3) is confirmed under the following conditions, normal measurement can not be done.

- ① FR-HC or FR-CV is connected.
- ② DC power supply is connected to the terminal + and –.
- ③ The power supply switched on during measurement.
- ④ The motor is not connected to the inverter.
- ⑤ The motor is running. (The motor is coasting.)
- ⑥ The motor capacity is two ranks (or more) smaller as compared to the inverter capacity.
- ⑦ The inverter is at an alarm stop or an alarm occurred while power is off.
- ⑧ The inverter output is shut off with the MRS signal.
- ⑨ The start command is given while measuring.
- ⑩ The parameter unit (FR-PU04/FR-PU07) is connected.
- ⑪ Use terminal PC as power supply.
- ⑫ I/O terminal of the control terminal block and plug-in option is on (continuity).
- ⑬ Plug-in option is fitted. (FR-E720S-050 or less, FR-E740-026 or less)

Turning the power on during measuring before LED of the operation panel turns off, it may remain in "measuring" (Pr. 259 = 2) status. In such case, carry out operation from step ②.

NOTE

For the accurate life measuring of the main circuit capacitor, perform after more than 3 hrs passed since the turn off of the power as it is affected by the capacitor temperature.

**WARNING:**

When measuring the main circuit capacitor capacity (Pr. 259 "Main circuit capacitor life measuring" = 1), the DC voltage is applied to the motor for 1s at powering off. Never touch the motor terminal, etc. right after powering off to prevent an electric shock.

Cooling fan life display

The cooling fan speed of 40% or less is detected and "FN" is displayed on the operation panel and parameter unit (FR-PU04/FR-PU07). As an alarm display, Pr. 255 bit 2 is turned on and also an alarm is output to the Y90 signal.

NOTE

When the inverter is mounted with two or more cooling fans, "FN" is displayed with one or more fans with speed of 50% or less.

6.21.3 Maintenance timer alarm (Pr. 503, Pr. 504)

When the cumulative energizing time of the inverter reaches the parameter set time, the maintenance timer output signal (Y95) is output. "MT" is displayed on the operation panel. This can be used as a guideline for the maintenance time of peripheral devices.

| Pr. No. | Name | Initial Value | Setting Range | Description | Parameters referred to | Refer to Section |
|------------|---|---------------|---------------|--|--|------------------|
| 503 | Maintenance timer | 0 | 0 (1-9998) | Display the cumulative energizing time of the inverter in 100h increments. Reading only Writing the setting of "0" clears the cumulative energizing time. | 190-192 Output terminal function selection | 6.10.5 |
| | | | | | | |
| 504 | Maintenance timer alarm output set time | 9999 | 0-9998 | Set the time taken until when the maintenance timer alarm output signal (Y95) is output. | | |
| | | | 9999 | No function | | |

The above parameters can be set when Pr. 160 "User group read selection" = 0.

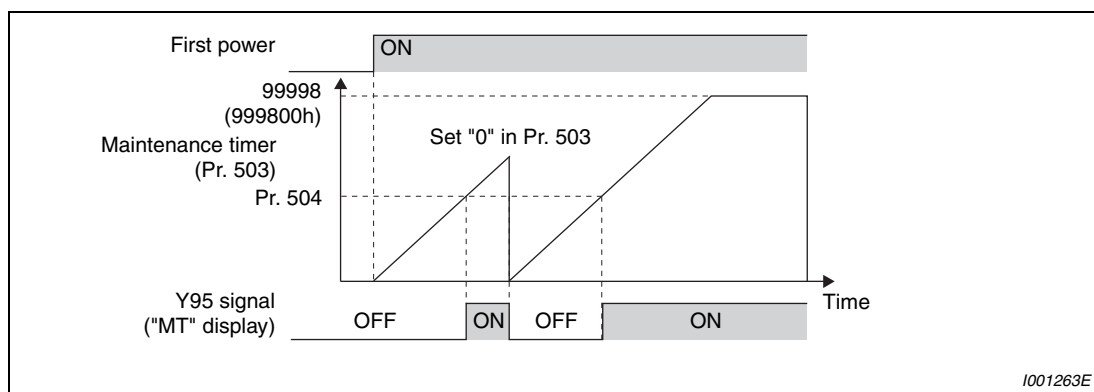

Fig. 6-153: Maintenance timer

The cumulative energizing time of the inverter is stored into the E²PROM every hour and indicated in Pr. 503 "Maintenance timer" in 100h increments. Pr. 503 is clamped at 9998 (999800h).

When the Pr. 503 value reaches the time set to Pr. 504 "Maintenance timer alarm output set time" (100h increments), the maintenance timer alarm output signal (Y95) is output.

For the terminal used for the Y95 signal output, assign the function by setting "95" (source logic) or "195" (sink logic) to any of Pr. 190 to Pr. 192 "Output terminal function selection".

NOTES

- | The cumulative energizing time is counted every hour. The energizing time of less than 1h is not counted.
- | When terminal assignment is changed using Pr. 190 to Pr. 192 "Output terminal function selection", the other functions may be affected. Please make setting after confirming the function of each terminal.

6.21.4 Current average value monitor signal (Pr. 555 to Pr. 557)

The average value of the output current during constant speed operation and the maintenance timer value are output as a pulse to the current average value monitor signal (Y93). The pulse width output to the I/O module of the PLC or the like can be used as a guideline due to abrasion of machines and elongation of belt and for aged deterioration of devices to know the maintenance time.

The current average value monitor signal (Y93) is output as pulse for 20s as 1 cycle and repeatedly output during constant speed operation.

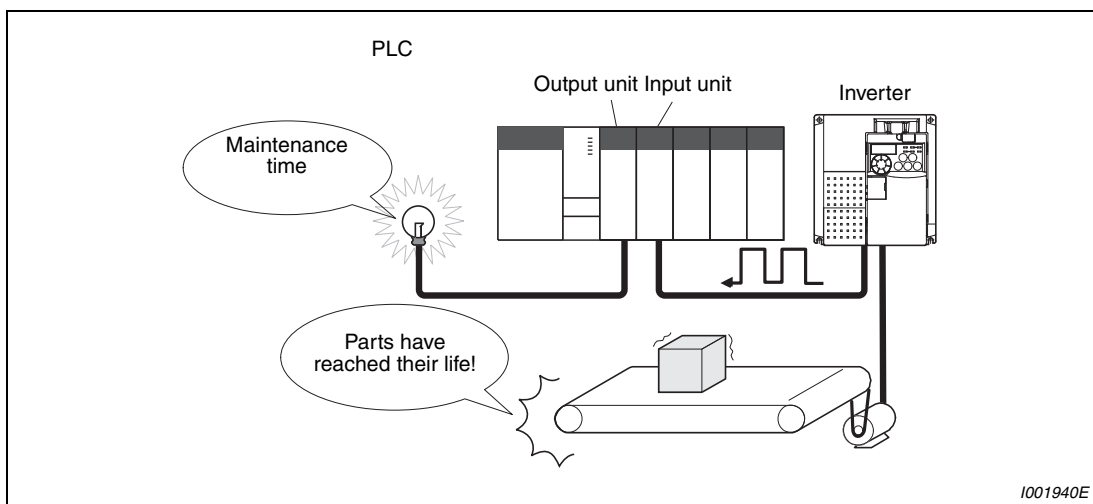

Fig. 6-154: Monitoring the maintenance timer and current average value

| Pr. No. | Name | Initial Value | Setting Range | Description | Parameters referred to | Refer to Section |
|------------|---|------------------------|---------------|--|---|----------------------------|
| 555 | Current average time | 1s | 0.1–1.0s | Set the time taken to average the current during start bit output (1s). | 57 Restart coasting time 190–192 Output terminal function selection 503 Maintenance timer | 6.12.1 6.10.5 6.21.3 |
| 556 | Data output mask time | 0s | 0.0–20.0s | Set the time for not obtaining (mask) transient state data. | | |
| 557 | Current average value monitor signal output reference current | Rated inverter current | 0–500A | Set the reference (100%) for outputting the signal of the current average value. | | |

The above parameters can be set when Pr. 160 "User group read selection" = 0.

The above parameters allow its setting to be changed during operation in any operation mode even if "0" (initial value) is set in Pr. 77 "Parameter write selection".

The pulse output of the current average value monitor signal (Y93) is shown below.

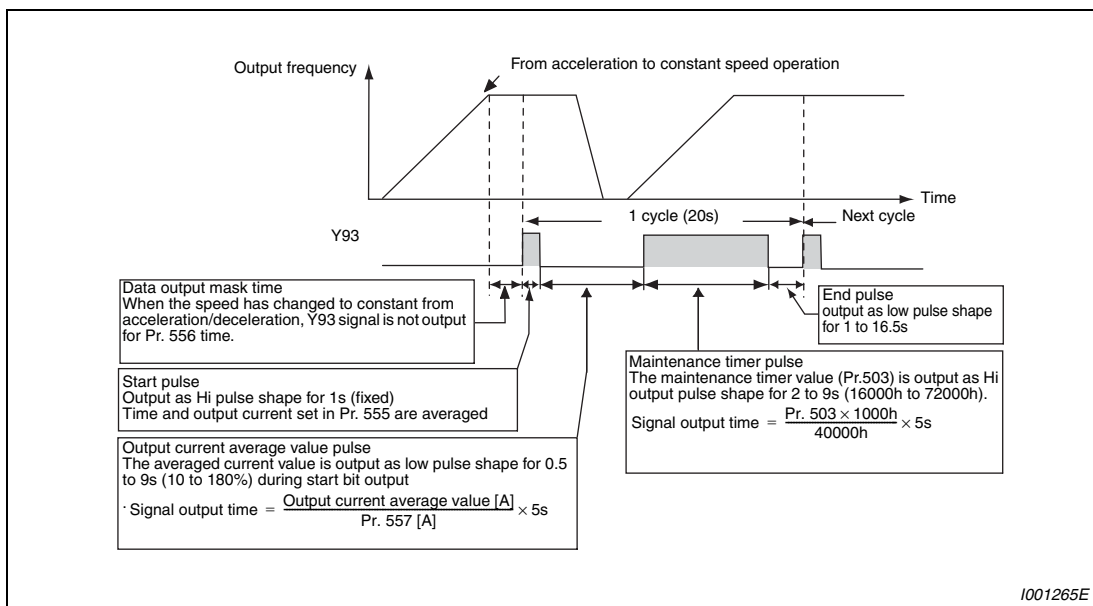

Fig. 6-155: Output of the pulse signal Y93

For the terminal used for the Y93 signal output, assign the function by setting "93" (positive logic) or "193" (negative logic) to Pr. 190 "RUN terminal function selection". The function can not be assigned to Pr. 192 "ABC terminal function selection".

Setting of Pr. 556 "Data output mask time"

The output current is unstable (transient state) right after the operation is changed from the acceleration/deceleration state to the constant speed operation. Set the time for not obtaining (mask) transient state data in Pr. 556.

Setting of the Pr. 555 "Current average time"

The average output current is calculated during Hi output of start bit (1s). Set the time taken to average the current during start bit output in Pr. 555.

Setting of Pr. 557 "Current average value monitor signal output reference current"

Set the reference (100%) for outputting the signal of the current average value. Obtain the time of the low pulse after a fixed start pulse of 1s from the following calculation.

$$\frac{\text{Output current average value}}{\text{Pr. 557}} \times 5\text{s (output current average value 100\%/5s)}$$

Note that the output time range is 0.5 to 9s, and it is 0.5s when the output current average value is less than 10% of the setting value of Pr. 557 and 9s when it exceeds 180%.

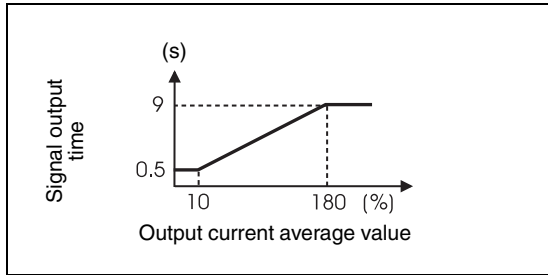

Fig. 6-156:
Signal output time for the current average value

1001266E

Example ▽

When Pr. 557 = 10A and the average value of output current is 15A, the current average value monitor signal is output as low pulse shape for 7.5s.

$$\text{Signal output time} = \frac{15\text{A}}{10\text{A}} \times 5\text{s} = 7.5\text{s}$$

△

Output of Pr. 503 "Maintenance timer"

After the output current average value is output as low pulse shape, the maintenance timer value is output as high pulse shape. The output time of the maintenance timer value is obtained from the following calculation.

$$\frac{\text{Pr. 503} \times 100}{40000\text{h}} \times 5\text{s (Maintenance timer value 100\%/5s)}$$

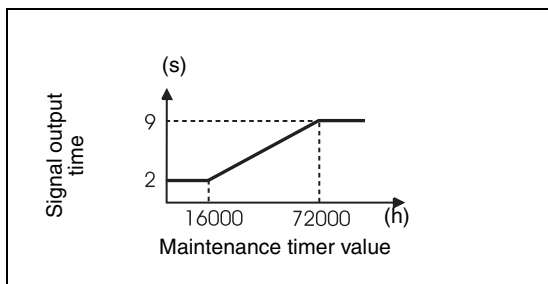

Fig. 6-157:
Signal output time for the maintenance output value

1001267E

Note that the output time range is 2 to 9s, and it is 2s when Pr. 503 is less than 16000h and 9s when it exceeds 72000h.

NOTES

Mask of data output and sampling of output current are not performed during acceleration/deceleration.

When the speed is changed to acceleration/deceleration from constant speed during start bit output, the data is judged as invalid, the start bit is output as high pulse shape for 3.5s, and the end signal is output as low pulse shape for 16.5s. The signal is output for at least 1 cycle even when acceleration/deceleration state continues after the start bit output is completed.

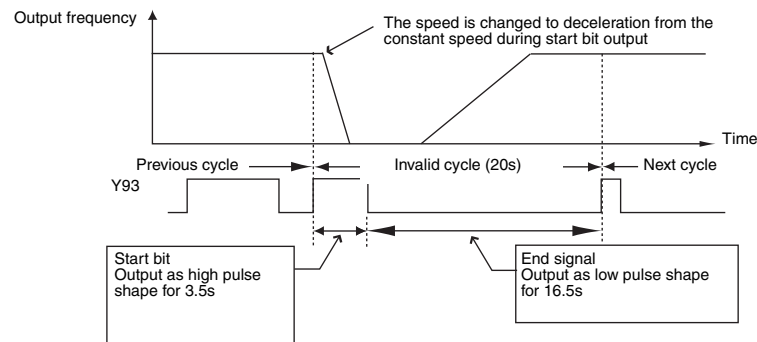

When the output current value (inverter output current monitor) is 0A on completion of the 1 cycle signal output, the signal is not output until the speed becomes constant next time.

The current average value monitor signal (Y93) is output as low pulse shape for 20s (without data output) under the following condition:

- When the motor is in the acceleration/deceleration state on completion of the 1 cycle signal output.
- When 1-cycle signal output was ended during restart operation with the setting of automatic restart after instantaneous power failure (Pr. 57 ≠ 9999).
- When automatic restart operation was being performed with automatic restart after instantaneous power failure selected (Pr. 57 ≠ 9999) on completion of the data output mask.

When terminal assignment is changed using Pr. 190 to Pr. 192 "Output terminal function selection", the other functions may be affected. Please make setting after confirming the function of each terminal.

6.21.5 Free parameters (Pr. 888, Pr. 889)

Parameters you can use for your own purposes.
You can input any number within the setting range "0" to "9999".

For example, the number can be used:

- As a unit number when multiple units are used.
- As a pattern number for each operation application when multiple units are used.
- As the year and month of introduction or inspection.

| Pr. No. | Name | Initial Value | Setting Range | Description | Parameters referred to | Refer to Section |
|------------|------------------|---------------|---------------|---|------------------------|------------------|
| 888 | Free parameter 1 | 9999 | 0–9999 | Any values can be set. Data is held even if the inverter power is turned off. | — | |
| 889 | Free parameter 2 | 9999 | 0–9999 | | | |

The above parameters can be set when Pr. 160 "User group read selection" = 0.

The above parameters allow its setting to be changed during operation in any operation mode even if "0" (initial value) is set in Pr. 77 "Parameter write selection".

NOTE

Pr. 888 and Pr. 889 do not influence the inverter operation.

6.22 Setting for the parameter unit, operation panel

| Purpose | Parameters that must be set | | Refer to Section |
|---|---------------------------------------|---------|------------------|
| Selection of rotation direction by the RUN key of the operation panel | RUN key rotation direction selection | Pr. 40 | 6.22.1 |
| Switch the display language of the parameter unit | PU display language selection | Pr. 145 | 6.22.2 |
| Use the setting dial of the operation panel like a volume for frequency setting. Key lock of operation panel | Operation panel operation selection | Pr. 161 | 6.22.3 |
| Change the magnitude of change of frequency setting by the setting dial of the operation panel | Magnitude of frequency change setting | Pr. 295 | 6.22.4 |
| Control of the parameter unit buzzer | PU buzzer control | Pr. 990 | 6.22.5 |
| Adjust LCD contrast of the parameter unit | PU contrast adjustment | Pr. 991 | 6.22.6 |

6.22.1 RUN key rotation direction selection (Pr. 40)

Used to choose the direction of rotation by operating the RUN key of the operation panel.

| Pr. No. | Name | Initial Value | Setting Range | Description | Parameters referred to | Refer to Section |
|---------|--------------------------------------|---------------|---------------|------------------|------------------------|------------------|
| 40 | RUN key rotation direction selection | 0 | 0 | Forward rotation | — | |
| | | | 1 | Reverse rotation | | |

The above parameter can be set when Pr. 160 "User group read selection" = 0.

6.22.2 PU display language selection (Pr. 145)

By using parameter 145 you can select the display language for the parameter unit FR-PU04/FR-PU07.

| Pr. No. | Name | Initial Value | Setting Value | Description | Parameters referred to | Refer to Section |
|---------|-------------------------------|---------------|---------------|-------------|------------------------|------------------|
| 145 | PU display language selection | 1 | 0 | Japanese | — | |
| | | | 1 | English | | |
| | | | 2 | German | | |
| | | | 3 | French | | |
| | | | 4 | Spanish | | |
| | | | 5 | Italian | | |
| | | | 6 | Swedish | | |
| 7 | Finnish | | | | | |

The above parameter can be set when Pr. 160 "User group read selection" = 0.

6.22.3 Operation panel frequency setting/key lock operation selection (Pr. 161)

The setting dial of the operation panel can be used like a potentiometer to perform operation. The key operation of the operation panel can be disabled.

| Pr. No. | Name | Initial Value | Setting Range | Description | Parameters referred to | Refer to Section |
|------------|--|---------------|---------------|-------------------------------------|--|------------------|
| 161 | Frequency setting/key lock operation selection | 0 | 0 | Setting dial frequency setting mode | Key lock mode invalid | — |
| | | | 1 | Setting dial potentiometer mode | | |
| | | | 10 | Setting dial frequency setting mode | Key lock mode valid These setting must be confirmed by pressing the MODE key for about 2 s. | |
| | | | 11 | Setting dial potentiometer mode | | |

The above parameter can be set when Pr. 160 "User group read selection" = 0.

NOTES

You can find a detailed description of the operation panel with examples in section 4.3 "Operation Panel".

When the setting dial and key operation is made invalid, "HOLD" appears on the operation panel while pressing a key.

The STOP/RESET key is valid even in the operation lock status.

6.22.4 Magnitude of frequency change setting (Pr. 295)

When setting the set frequency with the setting dial, frequency changes in 0.01Hz increments in the initial status. Setting this parameter increases the magnitude of frequency which changes according to the rotated amount of the setting dial, improving operability.

| Pr. No. | Name | Initial Value | Setting Range | Description | Parameters referred to | Refer to Section |
|---------|---------------------------------------|---------------|---------------|---|------------------------|------------------|
| 295 | Magnitude of frequency change setting | 0 | 0 | Function invalid | — | |
| | | | 0.01 | The minimum varying width when the set frequency is changed by the setting dial can be set. | | |
| | | | 0.10 | | | |
| | | | 1.00 | | | |
| | | | 10.00 | | | |

The above parameter can be set when Pr. 160 "User group read selection" = 0.

Example ▽

When "1.00Hz" is set in Pr. 295, one click (one dial gauge) of the setting dial changes the frequency in increments of 1.00Hz -> 2.00Hz -> 3.00Hz.

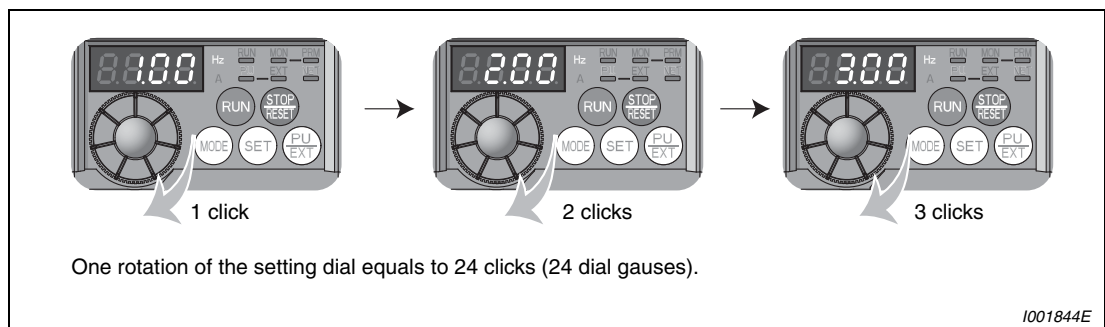

Fig. 6-158: Magnitude when parameter 295 is set to "1.00"



NOTES

- When machine speed display is selected with Pr. 37, the minimum increments of the magnitude of change is determined by Pr.295 as well. Note that the setting value may differ as speed setting changes the set machine speed and converts it to the speed display again.
- When the set frequency (speed) is 100 or more, frequency is displayed in 0.1 increments. Therefore, the minimum varying width is 0.1 even when Pr. 295 < 0.1.
- When the machine speed setting is 1000 or more, frequency is displayed in 1 increments. Therefore, the minimum varying width is 1 even when Pr. 295 < 1.
- For Pr. 295, unit is not displayed.
- This parameter is valid only in the set frequency mode. When other frequency-related parameters are set, it is not activated.
- When 10 is set, frequency setting changes in 10Hz increments. Note the excess speed (in potentiometer mode).

6.22.5 Buzzer control (Pr. 990)

You can make the buzzer "beep" when you press the key of the parameter unit (FR-PU04/FR-PU07).

| Pr. No. | Name | Initial Value | Setting Range | Description | Parameters referred to | Refer to Section |
|------------|-------------------|---------------|---------------|----------------|------------------------|------------------|
| 990 | PU buzzer control | 1 | 0 | Without buzzer | — | |
| | | | 1 | With buzzer | | |

The above parameter can be set when Pr. 160 "User group read selection" = 0.

The above parameter allows its setting to be changed during operation in any operation mode even if "0" (initial value) is set in Pr. 77 "Parameter write selection".

6.22.6 PU contrast adjustment (Pr. 991)

Contrast adjustment of the LCD of the parameter unit (FR-PU04/FR-PU07) can be performed. Decreasing the setting value makes contrast light. You should press the WRITE key to store the PU contrast setting.

| Pr. No. | Name | Initial Value | Setting Range | Description | Parameters referred to | Refer to Section |
|------------|------------------------|---------------|---------------|---------------------------|------------------------|------------------|
| 991 | PU contrast adjustment | 58 | 0–63 | 0: Light ↓ 63: Dark | — | |

The above parameter is displayed as simple mode parameter only when the parameter unit FR-PU04/FR-PU07 is connected.

The above parameters allow its setting to be changed during operation in any operation mode even if "0" (initial value) is set in Pr. 77 "Parameter write selection".

7 Troubleshooting

When an alarm occurs in the inverter, the protective function is activated bringing the inverter to an alarm stop and the PU display automatically changes to any of the following error (alarm) indications. If your fault does not correspond to any of the following errors or if you have any other problem, please contact your sales representative.

- Retention of fault output signal When the magnetic contactor (MC) provided on the input side of the inverter is opened at the activation of the protective function, the inverter's control power will be lost and the alarm output will not be held.
- Fault or alarm display When the protective function is activated, the operation panel display automatically switches to the above indication.
- Resetting method When a protective function of the inverter is activated, the power output of the inverter is blocked (motor is coasting). The inverter cannot start up again unless an automatic restart has been configured or the inverter is reset. Please observe carefully the warnings contained below in the configuration of an automatic restart or the execution of a reset.
- If protective functions were activated (i. e. the inverter switched off with an error message) follow the instructions for error correction provided in the manual for the inverter. Especially in the case of short circuits or earth contacts in the inverter output and mains over voltages the cause of the fault must be determined prior to switching on again as a recurrence of such faults at short intervals can lead to premature aging of components or even the complete breakdown of the device. After the cause of the fault has been found and corrected the inverter can be reset and operations continue.

7.1 List of alarm display

| Operation Panel Indication | | Name | Refer to Page | |
|----------------------------|----------------------------------|--------------------|--|------|
| Error message | <i>E---</i> | E--- | Faults history | 7-18 |
| | <i>HOLD</i> | HOLD | Operation panel lock | 7-4 |
| | <i>Er 1</i> to <i>Er 4</i> | Er1 to Er4 | Parameter write error | 7-4 |
| | <i>Err.</i> | Err. | Inverter reset | 7-5 |
| Warnings | <i>OL</i> | OL | Stall Prevention (overcurrent) | 7-6 |
| | <i>oL</i> | oL | Stall prevention (overvoltage) | 7-6 |
| | <i>rb</i> | RB | Regenerative brake prealarm | 7-7 |
| | <i>TH</i> | TH | Electronic thermal relay function prealarm | 7-7 |
| | <i>PS</i> | PS | PU Stop | 7-7 |
| | <i>MT</i> | MT | Maintenance signal output | 7-7 |
| | <i>UV</i> | UV | Undervoltage | 7-8 |
| Alarm | <i>Fn</i> | FN | Fan fault | 7-8 |
| Fault | <i>E.OC 1</i> | E.OC1 | Over current shut-off during acceleration | 7-8 |
| | <i>E.OC 2</i> | E.OC2 | Over current cut-off during constant speed | 7-9 |
| | <i>E.OC 3</i> | E.OC3 | Over current shutoff during deceleration or stop | 7-9 |
| | <i>E.OV 1</i> | E.OV1 | Regenerative over voltage cut-off during acceleration | 7-9 |
| | <i>E.OV 2</i> | E.OV2 | Over current cut-off during constant speed | 7-9 |
| | <i>E.OV 3</i> | E.OV3 | Regenerative over voltage shut-off during deceleration or stop | 7-10 |
| | <i>E.THT</i> | E.THT | Inverter overload shutoff (electronic thermal relay function) | 7-10 |
| | <i>E.THM</i> | E.THM | Motor overload shutoff (electronic thermal relay function) | 7-10 |
| | <i>E.FIN</i> | E.FIN | Fin overheat | 7-11 |
| | <i>E.ILF</i> | E.ILF ^① | Input phase failure | 7-11 |
| | <i>E.OLT</i> | E.OLT | Stall prevention | 7-11 |
| | <i>E. bE</i> | E.BE | Brake transistor alarm detection | 7-11 |
| | <i>E. GF</i> | E.GF | Output side earth (ground) fault over current protection | 7-12 |
| | <i>E. LF</i> | E.LF | Output phase failure protection | 7-12 |
| | <i>E.OHT</i> | E.OHT | External thermal relay operation | 7-12 |

Tab. 7-1: List of alarm display (1)

| Operation Panel Indication | | Name | Refer to Page | |
|----------------------------|-------------------------------|-------------------------------|---|------|
| Fault | E.OP1 | E.OP1 | Fault of the internal (extension slot) installed option (e.g. communication fault) | 7-12 |
| | E. 1 | E. 1 | Fault of the internal (extension slot) installed option (e.g. connection or contact fault respectively) | 7-13 |
| | E. PE | E.PE | Parameter storage device alarm | 7-13 |
| | E.PE2 | E.PE2 | Internal board fault | 7-13 |
| | E.PUE | E.PUE | PU disconnection | 7-13 |
| | E.RET | E.RET | Retry count excess | 7-14 |
| | E. 5 E. 6 E. 7 E.CPU | E. 5 E. 6 E. 7 E.CPU | CPU fault | 7-14 |
| | E.IOH | E.IOH ^① | Inrush resistor overheat | 7-14 |
| | E.AIE | E.AIE ^① | Analog input fault | 7-14 |
| | E.USB | E.USB ^① | USB communication fault | 7-15 |
| | E.MB4 to E.MB7 | E.MB4 to E.MB7 | Brake sequence fault | 7-15 |
| | E. 13 | E.13 | Internal circuit fault | 7-15 |

Tab. 7-1: List of alarm display (2)

① If when employing the operation unit FR-PU04 one of the errors "E.ILF, E.PE2, E.IOH, E.AIE, E.USB" occurs, then "Fault 14" will be displayed.

7.2 Causes and corrective actions

Error Message

A message regarding operational troubles is displayed. Output is not shutdown.

| | | |
|-----------------------------------|--|-------------|
| Operation Panel Indication | HOLD | <i>HOLD</i> |
| Name | Operation panel lock | |
| Description | Operation lock mode is set. Operation other than STOP/RESET is made invalid. (Refer to section 4.3.4.) | |
| Check point | — | |
| Corrective action | Press the MODE key for 2s to release lock. | |

| | | |
|-----------------------------------|--|-------------|
| Operation Panel Indication | Er1 | <i>Er 1</i> |
| Name | Write disable error | |
| Description | <ol style="list-style-type: none"> 1) You attempted to make parameter setting when Pr. 77 Parameter write selection has been set to disable parameter write. 2) Frequency jump setting range overlapped. 3) The PU and inverter cannot make normal communication. | |
| Check point | <ol style="list-style-type: none"> 1) Check the setting of Pr. 77 "Parameter write selection". (Refer to section 6.17.2.) 2) Check the settings of Pr. 31 to 36 (frequency jump). (Refer to section. 6.4.2.) 3) Check the connection of the PU and inverter. | |

| | | |
|-----------------------------------|--|-------------|
| Operation Panel Indication | Er2 | <i>Er 2</i> |
| Name | Write error during operation | |
| Description | When parameter write was performed during operation with a value other than "2" (writing is enabled independently of operation status in any operation mode) is set in Pr. 77 and the STF (STR) is on. | |
| Check point | <ol style="list-style-type: none"> 1) Check the Pr. 77 setting. (Refer to section 6.17.2.) 2) Check that the inverter is not operating. | |
| Corrective action | <ol style="list-style-type: none"> 1) Set "2" in Pr. 77. 2) After stopping operation, make parameter setting. | |

| | | |
|-----------------------------------|---|-------------|
| Operation Panel Indication | Er3 | <i>Er 3</i> |
| Name | Calibration error | |
| Description | Analog input bias and gain calibration values are too close. | |
| Corrective action | Check the settings of C3, C4, C6 and C7 (calibration functions). (Refer to section 6.16.3.) | |

| | | |
|-----------------------------------|---|------------|
| Operation Panel Indication | Er4 | Er4 |
| Name | Mode designation error | |
| Description | You attempted to make parameter setting in the NET operation mode when Pr. 77 is not "2". | |
| Check point | 1) Check that operation mode is "PU operation mode". 2) Check the Pr. 77 setting. (Refer to section 6.17.2.) | |
| Corrective action | 1) After setting the operation mode to the "PU operation mode", make parameter setting. (Refer to section 6.17.2.) 2) After setting "2" in Pr. 72, make parameter setting. | |

| | | |
|-----------------------------------|---|-------------|
| Operation Panel Indication | Err. | Err. |
| Name | Inverter reset | |
| Description | 1) Executing reset using RES signal, or reset command from communication or PU. 2) Displays at powering off. | |
| Corrective action | 1) Turn off the RES signal. | |

Warnings

When the protective function is activated, the output is not shut off.

| | | | | |
|-----------------------------------|--|--|--------------------|----|
| Operation Panel Indication | OL |  | FR-PU04 FR-PU07 | OL |
| Name | Stall prevention (overcurrent) | | | |
| Description | During acceleration | When the output current (output torque when Pr. 277 "Stall prevention current switchover" = 1) of the inverter exceeds the stall prevention operation level (Pr. 22 "Stall prevention operation level", etc.), this function stops the increase in frequency until the overload current decreases to prevent the inverter from resulting in overcurrent trip. When the overload current has reduced below stall prevention operation level, this function increases the frequency again. | | |
| | During constant-speed operation | When the output current (output torque when Pr. 277 "Stall prevention current switchover" = 1) of the inverter exceeds the stall prevention operation level (Pr. 22 "Stall prevention operation level", etc.), this function reduces frequency until the overload current decreases to prevent the inverter from resulting in overcurrent trip. When the overload current has reduced below stall prevention operation level, this function increases the frequency up to the set value. | | |
| | During deceleration | When the output current (output torque when Pr. 277 "Stall prevention current switchover" = 1) of the inverter exceeds the stall prevention operation level (Pr. 22 "Stall prevention operation level", etc.), this function stops the decrease in frequency until the overload current decreases to prevent the inverter from resulting in overcurrent trip. When the overload current has decreased below stall prevention operation level, this function decreases the frequency again. | | |
| Check point | <ol style="list-style-type: none"> 1) Check that the Pr. 0 "Torque boost" setting is not too large. 2) Check that the Pr. 7 "Acceleration time" and Pr. 8 "Deceleration time" settings are not too small. 3) Check that the load is not too heavy. 4) Are there any failure in peripheral devices? 5) Check that the Pr. 13 "Starting frequency" is not too large. 6) Check that the Pr. 22 "Stall prevention operation level" is appropriate. | | | |
| Corrective action | <ol style="list-style-type: none"> 1) Increase or decrease the Pr. 0 "Torque boost setting" 1% by 1% and check the motor status. (Refer to section 6.3.1.) 2) Set a larger value in Pr. 7 "Acceleration time" and Pr. 8 "Deceleration time". (Refer to section 6.7.1.) 3) Reduce the load weight. 4) Try advanced magnetic flux vector control and general-purpose magnetic flux vector control. 5) Change the Pr. 14 "Load pattern selection" setting. 6) Set stall prevention operation current in Pr. 22 "Stall prevention operation level". (The initial value is 150%.) The acceleration/deceleration time may change. Increase the stall prevention operation level with Pr. 22 "Stall prevention operation level", or disable stall prevention with Pr. 156 "Stall prevention operation selection". (Operation at OL occurrence can be selected using Pr. 156.) | | | |

| | | | | |
|-----------------------------------|--|---|--------------------|----|
| Operation Panel Indication | oL |  | FR-PU04 FR-PU07 | oL |
| Name | Stall prevention (overcurrent) | | | |
| Description | During deceleration | <ul style="list-style-type: none"> • If the regenerative energy of the motor becomes excessive and exceeds the regenerative energy consumption capability, this function stops the decrease in frequency to prevent over voltage shut-off. As soon as the regenerative energy has decreased, deceleration resumes. • If the regenerative energy of the motor becomes excessive when regeneration avoidance function is selected (Pr. 882 = 1), this function increases the speed to prevent over voltage shut-off. (Refer to section 6.20.4). | | |
| Check point | <ul style="list-style-type: none"> • Check for sudden speed reduction. • Check that regeneration avoidance function (Pr. 882, Pr. 883, Pr. 885, Pr. 886) is used. (Refer to section 6.20.4.) | | | |
| Corrective action | The deceleration time may change. Increase the deceleration time using Pr. 8 "Deceleration time". | | | |

| | | | | |
|-----------------------------------|---|---|--------------------|----|
| Operation Panel Indication | PS |  | FR-PU04 FR-PU07 | PS |
| Name | PU Stop | | | |
| Description | Stop with the STOP/RESET key of the PU is set in Pr. 75 "Reset selection/disconnected PU detection/PU stop selection". (For Pr. 75, refer to section 6.17.1.) | | | |
| Check point | Check for a stop made by pressing the STOP/RESET key of the operation panel. | | | |
| Corrective action | Turn the start signal off and release with PU/EXT key. | | | |

| | | | | |
|-----------------------------------|--|---|--------------------|----|
| Operation Panel Indication | RB |  | FR-PU04 FR-PU07 | RB |
| Name | Regenerative brake prealarm | | | |
| Description | <p>Appears if the regenerative brake duty reaches or exceeds 85% of the Pr. 70 "Special regenerative brake duty" value. When the setting of Pr. 70 "Special regenerative brake duty" is the initial value (Pr. 70 = 0), this warning does not occur.</p> <p>If the regenerative brake duty reaches 100%, a regenerative overvoltage (E. OV□) occurs. The RBP signal can be simultaneously output with the [RB] display. For the terminal used for the RBP signal output, assign the function by setting "7 (positive logic) or 107 (negative logic)" in any of Pr. 190 to Pr. 192 "Output terminal function selection". (Refer to section 6.10.5.)</p> | | | |
| Check point | <ul style="list-style-type: none"> • Check that the brake resistor duty is not high. • Check that the Pr. 30 "Regenerative function selection" and Pr. 70 "Special regenerative brake duty" values are correct. | | | |
| Corrective action | <ul style="list-style-type: none"> • Increase the deceleration time (Pr. 8). • Check the Pr. 30 "Regenerative function selection" and Pr. 70 "Special regenerative brake duty" values. | | | |

| | | | | |
|-----------------------------------|---|---|--------------------|----|
| Operation Panel Indication | TH |  | FR-PU04 FR-PU07 | TH |
| Name | Electronic thermal relay function prealarm | | | |
| Description | <p>Appears if the cumulative value of the Pr. 9 "Electronic thermal O/L relay" reaches or exceeds 85% of the preset level. If it reaches 100% of the Pr. 9 "Electronic thermal O/L relay" setting, a motor overload trip (E. THM) occurs. The THP signal can be simultaneously output with the [TH] display. For the terminal used for THP signal output, assign the function by setting "8 (positive logic) or 108 (negative logic)" in any of Pr. 190 to Pr. 192 "Output terminal function selection". (Refer to section 6.10.5.)</p> | | | |
| Check point | <p>1) Check for large load or sudden acceleration.</p> <p>2) Is the Pr. 9 "Electronic thermal O/L relay" setting is appropriate? (Refer to section 6.8.1.)</p> | | | |
| Corrective action | <p>1) Reduce the load weight or the number of operation times.</p> <p>2) Set an appropriate value in Pr. 9 "Electronic thermal O/L relay". (Refer to section 6.8.1.)</p> | | | |

| | | | | |
|-----------------------------------|--|---|--------------------|---|
| Operation Panel Indication | MT |  | FR-PU04 FR-PU07 | — |
| Name | Maintenance signal output | | | |
| Description | <p>Indicates that the cumulative energization time of the inverter has reached a given time. When the setting of Pr. 504 "Maintenance timer alarm output" set time is the initial value (Pr. 504 = 9999), this warning does not occur.</p> | | | |
| Check point | <p>The Pr. 503 "Maintenance timer" setting is larger than the Pr. 504 "Maintenance timer alarm output set time" setting. (Refer to section 6.21.3.)</p> | | | |
| Corrective action | <p>Setting "0" in Pr. 503 "Maintenance timer" erases the signal.</p> | | | |

| | | | | |
|-----------------------------------|---|---|--------------------|---|
| Operation Panel Indication | UV |  | FR-PU04 FR-PU07 | — |
| Name | Undervoltage | | | |
| Description | If the power supply voltage of the inverter decreases, the control circuit will not perform normal functions. In addition, the motor torque will be insufficient and/or heat generation will increase. To prevent this, if the power supply voltage decreases below about 230VAC, this function stops the inverter output and displays. An alarm is reset when the voltage returns to normal. | | | |
| Check point | Check that the power supply voltage is normal. | | | |
| Corrective action | Check that the power supply voltage is normal. | | | |

Alarm

When an alarm occurs, the output is not shut off. You can also output an alarm signal by making parameter setting. (Set "98" in any of Pr. 190 to Pr. 192 "Output terminal function selection". Refer to section 6.10.5).

| | | | | |
|-----------------------------------|--|---|--------------------|----|
| Operation Panel Indication | FN |  | FR-PU04 FR-PU07 | FN |
| Name | Fan fault | | | |
| Description | For the inverter that contains a cooling fan, "FN" appears on the operation panel when the cooling fan stops due to an alarm or different operation from the setting of Pr. 244 "Cooling fan operation selection". | | | |
| Check point | Check the cooling fan for an alarm. | | | |
| Corrective action | Replace the cooling fan. | | | |

Fault

When a fault occurs, the inverter trips and a fault signal is output.

| | | | | |
|-----------------------------------|--|---|--------------------|---------------|
| Operation Panel Indication | E.OC1 |  | FR-PU04 FR-PU07 | OC During Acc |
| Name | Over current shut-off during acceleration | | | |
| Description | When the inverter output current reaches or exceeds approximately 230% of the rated current during acceleration, the protective circuit is activated and the inverter trips. | | | |
| Check point | <ol style="list-style-type: none"> 1) Check for sudden acceleration. 2) Check that the downward acceleration time is not long in vertical lift application. 3) Check for output short circuit/ground fault. 4) Check that stall prevention operation is correct. 5) Check that regeneration is not performed frequently. (Check that the output voltage becomes larger than the V/f reference value at regeneration and overcurrent occurs due to the high voltage.) | | | |
| Corrective action | <ol style="list-style-type: none"> 1) Increase the acceleration time. (Shorten the downward acceleration time in vertical lift application.) 2) When "E.OC1" is always lit at starting, disconnect the motor once and start the inverter. If "E.OC1" is still lit, contact your sales representative. 3) Check the wiring to make sure that output short circuit/ground fault does not occur. 4) Perform a correct stall prevention operation. (Refer to section 6.3.5). 5) Set base voltage (rated voltage of the motor, etc.) in Pr. 19 "Base frequency voltage". (Refer to section 6.5.1.) | | | |

| | | | | |
|-----------------------------------|---|---|--------------------|---------------|
| Operation Panel Indication | E.OC2 |  | FR-PU04 FR-PU07 | OC During Dec |
| Name | Over current shut-off during constant speed | | | |
| Description | When the inverter output current reaches or exceeds approximately 230% of the rated current during constant speed operation, the protective circuit is activated and the inverter trips. | | | |
| Check point | <ol style="list-style-type: none"> 1) Check for sudden load change. 2) Check for output short circuit/ground fault. 3) Check that stall prevention operation is correct. | | | |
| Corrective action | <ol style="list-style-type: none"> 1) Keep load stable. 2) Check the wiring to make sure that output short circuit/ground fault does not occur. 3) Perform a correct stall prevention operation. (Refer to section 6.3.5). | | | |

| | | | | |
|-----------------------------------|---|---|--------------------|---------------|
| Operation Panel Indication | E.OC3 |  | FR-PU04 FR-PU07 | OC During Dec |
| Name | Over current shut-off during deceleration or stop | | | |
| Description | When the inverter output current reaches or exceeds approximately 230% of the rated inverter current during deceleration (other than acceleration or constant speed), the protective circuit is activated and the inverter trips. | | | |
| Check point | <ol style="list-style-type: none"> 1) Check for sudden speed reduction. 2) Check for output short circuit/ground fault. 3) Check for too fast operation of the motor's mechanical brake. 4) Check that stall prevention operation setting is correct. | | | |
| Corrective action | <ol style="list-style-type: none"> 1) Increase the deceleration time. 2) Check the wiring to make sure that output short circuit/ground fault does not occur. 3) Check the mechanical brake operation. 4) Check that stall prevention operation setting is correct. (Refer to section 6.3.5.) | | | |

| | | | | |
|-----------------------------------|--|---|--------------------|---------------|
| Operation Panel Indication | E.OV1 |  | FR-PU04 FR-PU07 | OV During Acc |
| Name | Regenerative over voltage shutoff during acceleration | | | |
| Description | If regenerative energy causes the inverter's internal main circuit DC voltage to reach or exceed the specified value, the protective circuit is activated and the inverter trips. The circuit may also be activated by a surge voltage produced in the power supply system. | | | |
| Check point | <ol style="list-style-type: none"> 1) Check for too slow acceleration (e.g. during downward acceleration in vertical lift load). 2) Check that the Pr. 22 "Stall prevention operation level" is not too low. | | | |
| Corrective action | <ol style="list-style-type: none"> 1) ● Decrease the acceleration time. <ul style="list-style-type: none"> ● Check that regeneration avoidance function (Pr. 882, Pr. 883, Pr. 885, Pr. 886) is used. (Refer to section 6.20.4) 2) Set a correct value in Pr. 22 "Stall prevention operation level". | | | |

| | | | | |
|-----------------------------------|--|---|--------------------|--------------|
| Operation Panel Indication | E.OV2 |  | FR-PU04 FR-PU07 | U>>N = konst |
| Name | Regenerative over voltage shut-off during constant speed | | | |
| Description | If regenerative energy causes the inverter's internal main circuit DC voltage to reach or exceed the specified value, the protective circuit is activated to stop the inverter output. The circuit may also be activated by a surge voltage produced in the power supply system. | | | |
| Check point | <ol style="list-style-type: none"> 1) Check for sudden load change. 2) Check that the Pr. 22 "Stall prevention operation level" is not too low. | | | |
| Corrective action | <ol style="list-style-type: none"> 1) ● Keep load stable. <ul style="list-style-type: none"> ● Check that regeneration avoidance function (Pr. 882, Pr. 883, Pr. 885, Pr. 886) is used. (Refer to section 6.20.4) ● Use the brake resistor, brake unit or power regeneration common converter (FR-CV) as required. 2) Set a correct value in Pr. 22 "Stall prevention operation level". | | | |

| | | | | |
|----------------------------|--|---|--------------------|---------------|
| Operation Panel Indication | E.OV3 |  | FR-PU04 FR-PU07 | OV During Dec |
| Name | Regenerative over voltage shut-off during deceleration or stop | | | |
| Description | If regenerative energy causes the inverter's internal main circuit DC voltage to reach or exceed the specified value, the protective circuit is activated to stop the inverter output. The circuit may also be activated by a surge voltage produced in the power supply system. | | | |
| Check point | Check for sudden speed reduction. | | | |
| Corrective action | <ul style="list-style-type: none"> • Increase the deceleration time. (Set the deceleration time which matches the inertia moment of the load) • Use regeneration avoidance function (Pr. 882, Pr. 883, Pr. 885, Pr. 886). (Refer to section 6.20.4.) • Use the brake unit or power regeneration common converter (FR-CV) as required. | | | |

| | | | | |
|----------------------------|---|---|--------------------|---------------|
| Operation Panel Indication | E.THT |  | FR-PU04 FR-PU07 | Inv. Overload |
| Name | Inverter overload shut-off (electronic thermal relay function) ① | | | |
| Description | If the temperature of the output transistor element exceeds the protection level under the condition that a current not less than the rated inverter current flows and overcurrent trip does not occur (230% or less), the electronic thermal relay activates to stop the inverter output. (Overload capacity 150% for 60s, 200% for 3s) | | | |
| Check point | <ul style="list-style-type: none"> • Check that acceleration/deceleration time is not too short. • Check that torque boost setting is not too large (small). • Check that load pattern selection setting is appropriate for the load pattern of the using machine. • Check the motor for use under overload. • Check for too high ambient temperature. | | | |
| Corrective action | <ul style="list-style-type: none"> • Increase acceleration/deceleration time. • Adjust the torque boost setting. • Set the load pattern selection setting according to the load pattern of the using machine. • Reduce the load weight. • Set the ambient temperature to within the specifications. | | | |

① Resetting the inverter initializes the internal thermal integrated data of the electronic thermal relay function.

| | | | | |
|----------------------------|--|---|--------------------|----------------|
| Operation Panel Indication | E.THM |  | FR-PU04 FR-PU07 | Motor Overload |
| Name | Motor overload shut-off (electronic thermal relay function) ① | | | |
| Description | The electronic thermal relay function in the inverter detects motor overheat due to overload or reduced cooling capability during constant-speed operation and pre-alarm (TH display) is output when the I ² t value reaches 85% of the Pr. 9 "Electronic thermal O/L relay" setting and the protection circuit is activated to stop the inverter output when the I ² t value reaches the specified value. When running a special motor such as a multi-pole motor or multiple motors, provide a thermal relay on the inverter output side since such motor(s) cannot be protected by the electronic thermal relay function. | | | |
| Check point | <ol style="list-style-type: none"> 1) Check the motor for use under overload. 2) Check that the setting of Pr. 71 "Applied motor" for motor selection is correct. (Refer to section 6.8.2.) 3) Check that the setting of Pr. 71 "Applied motor" for motor selection is correct. (Refer to section 6.3.5.) | | | |
| Corrective action | <ol style="list-style-type: none"> 1) Reduce the load weight. 2) For a constant-torque motor, set the constant-torque motor in Pr. 71 "Applied motor". 3) Check that stall prevention operation setting is correct. (Refer to section 6.3.5.) | | | |

① Resetting the inverter initializes the internal thermal integrated data of the electronic thermal relay function.

| | | | | |
|----------------------------|---|--------------|--------------------|---------------|
| Operation Panel Indication | E.FIN | <i>E.FIN</i> | FR-PU04 FR-PU07 | H/Sink O/Temp |
| Name | Fin overheat | | | |
| Description | If the heatsink overheats, the temperature sensor is actuated to stop the inverter output. The FIN signal can be output when the temperature becomes approximately 85% of the heatsink overheat protection operation temperature. For the terminal used for the FIN signal output, assign the function by setting "26" (source logic) or "126" (sink logic) in any of Pr. 190 to Pr. 192 "Output terminal function selection". (Refer to section 6.10.5). | | | |
| Check point | <ol style="list-style-type: none"> 1) Check for too high ambient temperature. 2) Check for heatsink clogging. 3) Check that the cooling fan is stopped. (Check that "FN" is not displayed on the operation panel.) | | | |
| Corrective action | <ol style="list-style-type: none"> 1) Set the ambient temperature to within the specifications. 2) Clean the heatsink. 3) Replace the cooling fan. | | | |

| | | | | |
|----------------------------|---|--------------|---------|------------------|
| Operation Panel Indication | E.ILF | <i>E.ILF</i> | FR-PU04 | Fault 14 |
| | | | FR-PU07 | Input phase loss |
| Name | Input phase failure ^① | | | |
| Description | Inverter trips when function valid setting (=1) is selected in Pr. 872 Input phase loss protection selection and one phase of the three phase power input is lost. (Refer to section 6.13.2). It may function if phase-to-phase voltage of the three-phase power input becomes largely unbalanced. | | | |
| Check point | <ul style="list-style-type: none"> • Check for a brake in the cable for the three-phase power supply input. • Check that phase-to-phase voltage of the three-phase power input is not largely unbalanced. | | | |
| Corrective action | <ul style="list-style-type: none"> • Wire the cables properly. • Repair a brake portion in the cable. • Check the Pr. 872 "Input phase failure protection selection" setting. • Set Pr. 872 = "0" (without input phase loss protection) when three-phase input voltage is largely unbalanced. | | | |

^① Available only for three-phase power input specification model.

| | | | | |
|----------------------------|---|--------------|--------------------|---|
| Operation Panel Indication | E.OLT | <i>E.OLT</i> | FR-PU04 FR-PU07 | Stall Prev STP (OL shown during stall prevention operation) |
| Name | Stall prevention | | | |
| Description | If the output frequency has fallen to 1Hz by stall prevention operation and remains for 3s, a fault (E.OLT) appears and trips the inverter. "OL" appears while stall prevention is being activated. E.OLT may not occur if stall prevention (OL) is activated during output phase loss. | | | |
| Check point | Check the motor for use under overload. (Refer to section 6.3.5). | | | |
| Corrective action | <ul style="list-style-type: none"> • Reduce the load weight. • Check the Pr. 22 "Stall prevention operation level" setting. | | | |

| | | | | |
|----------------------------|--|--------------|--------------------|----------------|
| Operation Panel Indication | E.BE | <i>E. BE</i> | FR-PU04 FR-PU07 | Br. Cct. Fault |
| Name | Brake transistor alarm detection/internal circuit error | | | |
| Description | When a brake transistor alarm has occurred due to the large regenerative energy from the motor etc., the brake transistor alarm is detected and the inverter trips. In this case, the inverter must be powered off immediately. | | | |
| Check point | <ul style="list-style-type: none"> • Reduce the load inertia. • Check that the frequency of using the brake is proper. | | | |
| Corrective action | Replace the inverter. | | | |

| | | | | |
|----------------------------|---|--------------|--------------------|--------------|
| Operation Panel Indication | E.GF | <i>E. GF</i> | FR-PU04 FR-PU07 | Ground Fault |
| Name | Output phase failure protection | | | |
| Description | The inverter trips if an earth (ground) fault overcurrent flows at start due to an earth (ground) fault that occurred on the inverter's output side (load side). Whether this protective function is used or not is set with Pr. 249 "Earth (ground) fault detection at start". | | | |
| Check point | Check for an earth fault in the motor and connection cable. | | | |
| Corrective action | Remedy the earth fault portion. | | | |

| | | | | |
|----------------------------|---|--------------|--------------------|------|
| Operation Panel Indication | E.LF | <i>E. LF</i> | FR-PU04 FR-PU07 | E.LF |
| Name | Output phase loss | | | |
| Description | If one of the three phases (U, V, W) on the inverter's output side (load side) is lost during inverter operation (except during DC injection brake operation and when output frequency is under 1Hz), inverter stops the output. Whether the protective function is used or not is set with Pr. 251 "Output phase loss protection selection". | | | |
| Check point | <ul style="list-style-type: none"> • Check the wiring (Check that the motor is normal.) • Check that the capacity of the motor used is not smaller than that of the inverter. | | | |
| Corrective action | <ul style="list-style-type: none"> • Wire the cables properly. • Check the Pr. 251 "Output phase failure protection selection" setting. | | | |

| | | | | |
|----------------------------|--|--------------|--------------------|----------|
| Operation Panel Indication | E.OHT | <i>E.OHT</i> | FR-PU04 FR-PU07 | OH Fault |
| Name | External thermal relay operation ^① | | | |
| Description | If the external thermal relay provided for motor overheat protection or the internally mounted temperature relay in the motor, etc. switches on (contacts open), the inverter output is stopped. Functions when "7" (OH signal) is set to any of Pr. 178 to Pr. 184 "Input terminal function selection". This protective function does not function in the initial status (OH signal is not assigned). | | | |
| Check point | <ul style="list-style-type: none"> • Check for motor overheating. • Check that the value of "7" (OH signal) is set correctly in any of Pr. 178 to Pr. 184 "Input terminal function selection". | | | |
| Corrective action | <ul style="list-style-type: none"> • Reduce the load and frequency of operation. • Even if the relay contacts are reset automatically, the inverter will not restart unless it is reset. | | | |

^① Functions only when any of Pr. 178 to Pr. 184 "Input terminal function selection" is set to OH.

| | | | | |
|----------------------------|--|--------------|--------------------|---------------------|
| Operation Panel Indication | E.OP1 | <i>E.OP1</i> | FR-PU04 FR-PU07 | Option slot alarm 1 |
| Name | Communication option fault | | | |
| Description | Stops the inverter output when a communication line fault occurs in the communication option. | | | |
| Check point | <ul style="list-style-type: none"> • Check for a wrong option function setting and operation. • Check that the plug-in option unit is plugged into the connector securely. • Check for a break in the communication cable. • Check that the terminating resistor is fitted properly. | | | |
| Corrective action | <ul style="list-style-type: none"> • Check the option function setting, etc. • Connect the plug-in option securely. • Check the connection of communication cable. • Connect the terminating resistor correctly. | | | |

| | | | | |
|-----------------------------------|---|---|--------------------|--|
| Operation Panel Indication | E.1 |  | FR-PU04 FR-PU07 | |
| Name | Option fault | | | |
| Description | <ul style="list-style-type: none"> Stops the inverter output if a contact fault or the like of the connector between the inverter and communication option occurs. Appears when the switch for the manufacturer setting of the plug-in option is changed. | | | |
| Check point | <ul style="list-style-type: none"> Check that the plug-in option is plugged into the connector securely. Check for excess electrical noises around the inverter. Check the switch position for the manufacturer setting of the plug-in option. | | | |
| Corrective action | <ul style="list-style-type: none"> Connect the plug-in option securely. Take measures against noises if there are devices producing excess electrical noises around the inverter. If the problem still persists after taking the above measure, please contact your sales representative or distributor. Return the switch position for the manufacturer setting of the plug-in option to the initial status. (Refer to the instruction manual of each option) | | | |

| | | | | |
|-----------------------------------|--|---|--------------------|---------------|
| Operation Panel Indication | E.PE |  | FR-PU04 FR-PU07 | Corrupt Memry |
| Name | Parameter storage device alarm (control circuit board) | | | |
| Description | Stops the inverter output if fault occurred in the parameter stored. (E ² PROM fault) | | | |
| Check point | Check for too many number of parameter write times. | | | |
| Corrective action | Please contact your sales representative. When performing parameter write frequently for communication purposes, set "1" in Pr. 342 to enable RAM write. Note that powering off returns the inverter to the status before RAM write. | | | |

| | | | | |
|-----------------------------------|---|---|--------------------|------------------------------|
| Operation Panel Indication | E.PE2 |  | FR-PU04 FR-PU07 | Fault 14 PR storage alarm |
| Name | Internal board fault | | | |
| Description | When a combination of control board and main circuit board is wrong, the inverter is tripped. | | | |
| Check point | — | | | |
| Corrective action | Please contact your sales representative. | | | |

| | | | | |
|-----------------------------------|--|---|--------------------|--------------|
| Operation Panel Indication | E.PUE |  | FR-PU04 FR-PU07 | PU Leave Out |
| Name | PU disconnection | | | |
| Description | This function stops the inverter output if communication between the inverter and PU is suspended, e.g. the parameter unit is disconnected, when "2", "3", "16" or "17" was set in Pr. 75 "Reset selection/disconnected PU detection/PU stop selection". This function stops the inverter output when communication errors occurred consecutively for more than permissible number of retries when a value other than "9999" is set in Pr. 121 "Number of PU communication retries" during the RS-485 communication with the PU connector (use Pr. 502 "Stop mode selection at communication error" to change). This function also stops the inverter output if communication is broken within the period of time set in Pr. 122 "PU communication check time interval" during the RS-485 communication with the PU connector. | | | |
| Check point | <ul style="list-style-type: none"> Check that the parameter unit (FR-PU04/FR-PU07) is fitted tightly. Check the Pr. 75 setting. | | | |
| Corrective action | Connect the parameter unit (FR-PU04/FR-PU07) securely. | | | |

| | | | | |
|-----------------------------------|--|-----------------|----------------------------|----------------------|
| Operation Panel Indication | E.RET | E. r E r | FR-PU04 FR-PU07 | Retry No Over |
| Name | Retry count excess | | | |
| Description | If operation cannot be resumed properly within the number of retries set, this function trips the inverter. Functions only when Pr. 67 "Number of retries at fault occurrence" is set. When the initial value (Pr. 67 = 0) is set, this protective function does not function. | | | |
| Check point | Find the cause of fault occurrence. | | | |
| Corrective action | Eliminate the cause of the error preceding this error indication. | | | |

| | | | | |
|-----------------------------------|--|--------------|----------------------------|------------------|
| Operation Panel Indication | E. 5 | E. 5 | FR-PU04 FR-PU07 | Fault 5 |
| | E. 6 | E. 6 | | Fault 6 |
| | E. 7 | E. 7 | | Fault 7 |
| | E.CPU | E.CPU | | CPU Fault |
| Name | CPU fault | | | |
| Description | Stops the inverter output if the communication fault of the built-in CPU occurs. | | | |
| Check point | Check for devices producing excess electrical noises around the inverter. | | | |
| Corrective action | <ul style="list-style-type: none"> • Take measures against noises if there are devices producing excess electrical noises around the inverter. • Please contact your sales representative. | | | |

| | | | | |
|-----------------------------------|--|---------------|----------------------------|------------------------|
| Operation Panel Indication | E.IOH | E. IOH | FR-PU04 FR-PU07 | Fault 14 |
| | | | | Inrush overheat |
| Name | Inrush current limit circuit fault | | | |
| Description | Stops the inverter output when the resistor of inrush current limit circuit overheated. The inrush current limit circuit fault. | | | |
| Check point | Check that frequent power ON/OFF is not repeated. | | | |
| Corrective action | Configure a circuit where frequent power ON/OFF is not repeated. If the problem still persists after taking the above measure, please contact your sales representative. | | | |

| | | | | |
|-----------------------------------|--|-----------------|----------------------------|------------------------|
| Operation Panel Indication | E.AIE | E. A I E | FR-PU04 FR-PU07 | Fault 14 |
| | | | | Analog in error |
| Name | Analog input fault | | | |
| Description | Appears if voltage(current) is input to terminal 4 when the setting in Pr. 267 "Terminal 4 input selection" and the setting of voltage/current input switch are different. | | | |
| Check point | Check the setting of Pr. 267 "Terminal 4 input selection" and voltage/current input switch. | | | |
| Corrective action | Either give a frequency command by current input or set Pr. 267 Terminal 4 input selection, and voltage/current input switch to voltage input. (Refer to section 6.16.1.) | | | |

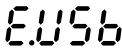
| | | | | |
|-----------------------------------|--|---|---------|----------------|
| Operation Panel Indication | E.USB |  | FR-PU04 | Fault 14 |
| | | | FR-PU07 | USB comm error |
| Name | USB communication fault | | | |
| Description | When communication has broken during the time set in Pr. 548 "USB communication check time interval", this function stops the inverter output. | | | |
| Check point | <ul style="list-style-type: none"> • Check the USB communication cable. • Check the Pr. 548 "USB communication check time interval setting". | | | |
| Corrective action | <ul style="list-style-type: none"> • Check the USB communication cable. • Increase the Pr. 548 "USB communication check time interval setting". Or, change the setting to 9999. (Refer to section 6.19.6.) | | | |

| | | | | |
|-----------------------------------|---|---|---------|----------------------------|
| Operation Panel Indication | E.MB4 to E.MB7 |  | FR-PU04 | E.MB4 Fault to E.MB7 Fault |
| | | | FR-PU07 | |
| Name | Brake sequence fault | | | |
| Description | The inverter output is stopped when a sequence error occurs during use of the brake sequence function (Pr. 278 to Pr. 283). This protective function does not function in the initial status. (Refer to section 6.9.5.) | | | |
| Check point | Find the cause of alarm occurrence. | | | |
| Corrective action | Check the set parameters and perform wiring properly. | | | |

| | | | | |
|-----------------------------------|---|---|--------------------|----------|
| Operation Panel Indication | E.13 |  | FR-PU04 FR-PU07 | Fault 13 |
| Name | Internal circuit fault | | | |
| Description | Stop the inverter output when an internal circuit fault occurred. | | | |
| Corrective action | Please contact your sales representative. | | | |

NOTES

- If protective functions of E.ILF, E.PE2, E.IOH, E.AIE or E.USB are activated when using the FR-PU04, "Fault 14" is displayed. Also when the faults history is checked on the FR-PU04, the display is "E.14".
- If faults other than the above appear, contact your sales representative.

7.3 Reset method of protective function

Eliminate the cause of the error before you reset the inverter. Note that the internal thermal integrated value of the electronic thermal relay function and the number of retries are cleared (erased) by resetting the inverter. It takes about 1s for reset.

The inverter can be reset by performing any of the following operations:

- Using the operation panel, press the STOP/RESET key to reset the inverter. (Enabled only when the inverter protective function is activated (major fault). (Refer to page 7-8 for major fault.))

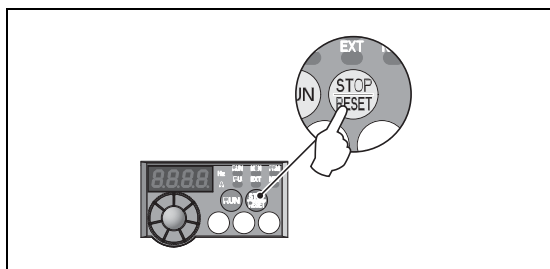

Fig. 7-1:
Resetting the inverter by using the operation panel

1001859E

- Switch OFF the power once, then switch it ON again after the indicator of the operation panel turns OFF.

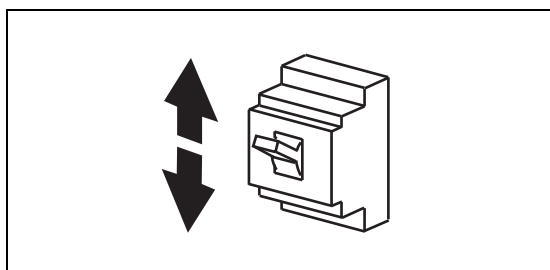

Fig. 7-2:
Resetting the inverter by switching the power supply off an on

1001297E

- Turn on the reset signal RES for more than 0.1s. (Connect the terminals RES and SD when using sink logic or terminals RES and PC as shown Fig. 7-3 when using source logic). (If the RES signal is kept on, "Err." appears (flickers) to indicate that the inverter is in the reset status.)

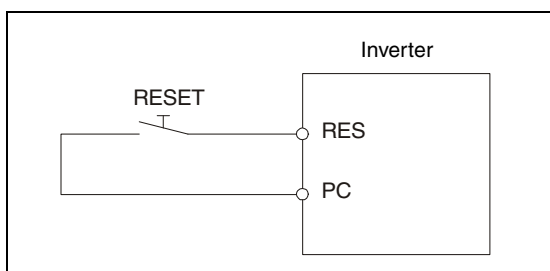

Fig. 7-3:
Resetting the inverter by turning on the RES signal

1000249C

7.4 LED display

There are the following correspondences between the actual alphanumeric characters and the digital characters displayed on the operation panel.

| | | | | | |
|---|---|---|---|---|---|
| 0 | 0 | A | A | L | L |
| 1 | 1 | B | b | M | M |
| 2 | 2 | C | C | N | n |
| 3 | 3 | D | d | O | 0 |
| 4 | 4 | E | E | P | P |
| 5 | 5 | F | F | R | r |
| 6 | 6 | G | G | S | 5 |
| 7 | 7 | H | H | T | C |
| 8 | 8 | I | I | U | U |
| 9 | 9 | J | J | V | U |

1000299C

Fig. 7-4: Correspondences between digital and actual characters (operation panel)

7.5 Check and clear of the fault history

Check for the fault history

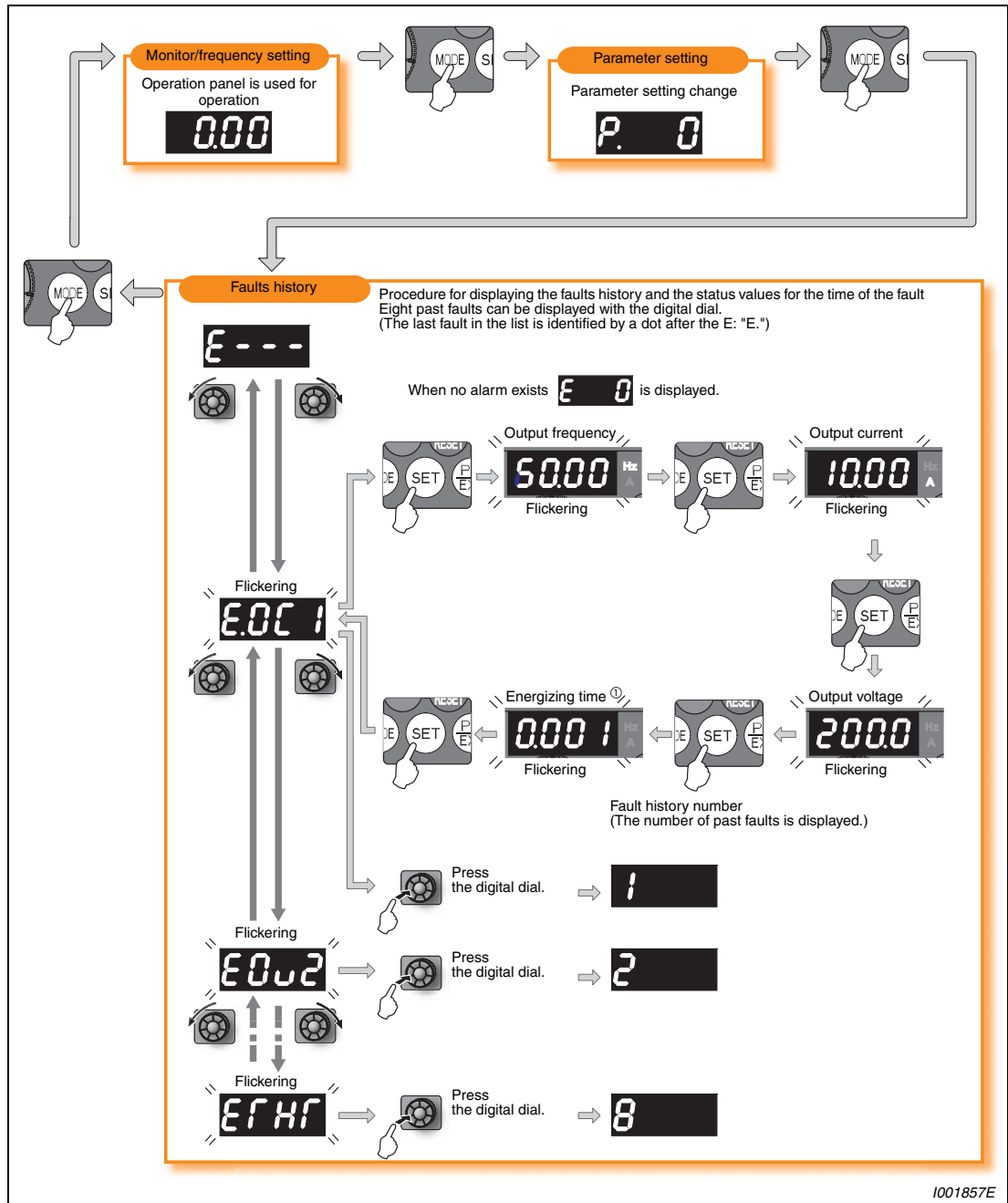

Fig. 7-5: Displaying the fault list and the status values for the time of the fault

- ① The cumulative energization time and actual operation time are accumulated from 0 to 65535 hours, then cleared, and accumulated again from 0. When the operation panel is used, the time is displayed up to 65.53 (65530h) in the indication of 1h = 0.001, and thereafter, it is added up from 0.

Clearing procedure

The fault history can be cleared by setting "1" in Er.CL "Faults history clear". (The fault history is not cleared when "1" is set in Pr. 77 "Parameter write selection".)

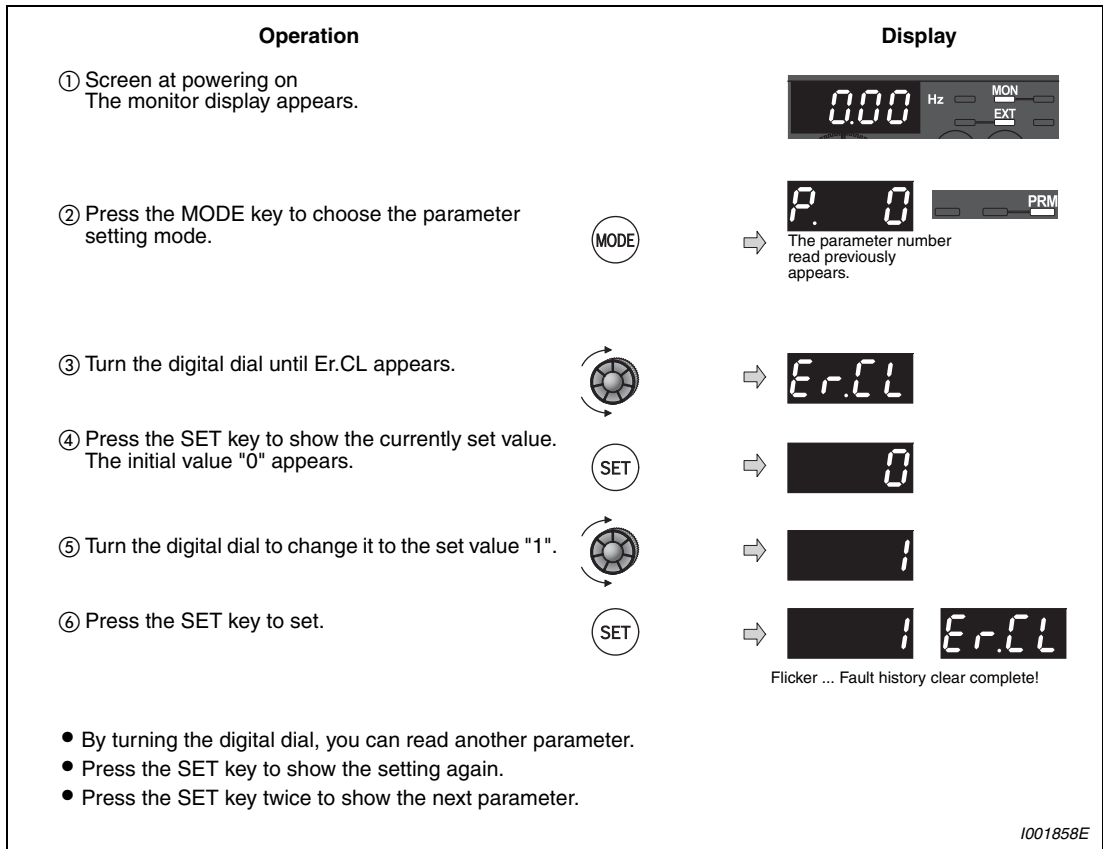

Fig. 7-6: Clearing the fault history

7.6 Check first when you have troubles

7.6.1 Motor does not start

| Check points | Possible Cause | Countermeasures | Refer to page |
|--------------|--|---|---------------|
| Main Circuit | Appropriate power supply voltage is not applied. (Operation panel display is not provided.) | Power ON a moulded case circuit breaker (MCCB), an earth leakage circuit breaker (ELB), or a magnetic contactor (MC). Check for the decreased input voltage, input phase loss, and wiring. | — |
| | Motor is not connected properly. | Check the wiring between the inverter and the motor. | 3-6 |
| | The jumper across + and P1 is disconnected. | Securely fit a jumper across + and P1. When using a DC reactor (FFR-HEL-(H)-E), remove the jumper across + and P1, and then connect the DC reactor. | 3-37 |
| Input Signal | Start signal is not input. | Check the start command source, and input a start signal. PU operation mode: RUN key External operation mode : STF/STR signal | 6-201 |
| | Both the forward and reverse rotation start signals (STF, STR) are input simultaneously. | Turn ON only one of the forward and reverse rotation start signals (STF or STR). When the STF and STR signals are turned ON simultaneously, a stop command is given. | 3-14 |
| | Frequency command is zero. | Check the frequency command source and enter a frequency command. (When the frequency command is 0Hz and the run command is entered, RUN LED of the operation panel flickers.) | 6-201 |
| | AU signal is not ON when terminal 4 is used for frequency setting. | Turn ON the AU signal. Turning ON the AU signal activates terminal 4 input. | 3-14 |
| | Output stop signal (MRS) or reset signal (RES) is ON. | Turn MRS or RES signal OFF. Inverter starts the operation with a given start command and a frequency command after turning OFF MRS or RES signal. Before turning OFF, ensure the safety. | 6-117, 7-16 |
| | Jumper connector of sink - source is wrongly selected. | Check that the control logic switchover jumper connector is correctly installed. If it is not installed correctly, input signal is not recognized. | 3-20 |
| | Voltage/current input switch is not correctly set for analog input signal (0 to 5V/0 to 10V, 4 to 20mA). | Set Pr. 73, Pr. 267, and a voltage/current input switch correctly, then input an analog signal in accordance with the setting. | 3-14 |
| | The STOP/RESET key was pressed (Operation panel indication is "PS".) | During the External operation mode, check the method of restarting from a STOP/RESET key input stop from PU. | 7-7 |
| | Two-wire or three-wire type connection is wrong. | Check the connection. Connect STOP signal when three-wire type is used. | 6-120 |

| Check points | Possible Cause | Countermeasures | Refer to page |
|---|--|--|---------------|
| Parameter Setting | Pr. 0 "Torque boost" setting is improper when V/F control is used. | Increase Pr. 0 setting by 0.5% increments while observing the rotation of a motor. If that makes no difference, decrease the setting. | 6-33 |
| | Pr. 78 "Reverse rotation prevention selection" is set. | Check the Pr. 78 setting. Set Pr. 78 when you want to limit the motor rotation to only one direction. | 6-194 |
| | Pr. 79 "Operation mode selection" setting is wrong. | Select the operation mode which corresponds with input methods of start command and frequency command. | 6-201 |
| | Bias and gain (calibration parameter C2 to C7) settings are improper. | Check the bias and gain (calibration parameter C2 to C7) settings. | 6-180 |
| | Pr. 13 "Starting frequency" setting is greater than the running frequency. | Set running frequency higher than Pr. 13. The inverter does not start if the frequency setting signal is less than the value set in Pr. 13. | 6-73 |
| | Frequency settings of various running frequency (such as multi-speed operation) are zero. Especially, Pr. 1 "Maximum frequency" is zero. | Set the frequency command according to the application. Set Pr. 1 higher than the actual frequency used. | 6-50 |
| | Pr. 15 "Jog frequency" setting is lower than Pr. 13 "Starting frequency". | Set Pr. 15 "Jog frequency" higher than Pr. 13 "Starting frequency". | 6-61 |
| | Operation mode and a writing device do not match. | Check Pr. 79, Pr. 338, Pr. 339, Pr. 550, Pr. 551, and select an operation mode suitable for the purpose. | 6-198, 6-212 |
| | Start signal operation selection is set by the Pr. 250 "Stop selection". | Check Pr. 250 setting and connection of STF and STR signals. | 6-120 |
| | Inverter decelerated to a stop when power failure deceleration stop function is selected. | When power is restored, ensure the safety, and turn OFF the start signal once, then turn ON again to restart. Inverter restarts when Pr. 261="2". | 6-162 |
| | Performing auto tuning. | When offline auto tuning ends, press the STOP/RESET key of the operation panel for the PU operation. For the External operation, turn OFF the start signal (STF or STR). This operation resets the offline auto tuning, and the PU's monitor display returns to the normal indication. (Without this operation, next operation cannot be started.) | 6-88 |
| Automatic restart after instantaneous power failure function or power failure stop function is activated. (Performing overload operation with single-phase power input specification model may cause voltage insufficiency, and results in a detection of power failure.) | <ul style="list-style-type: none"> ● Disable the automatic restart after instantaneous power failure function and power failure stop function. ● Reduce the load. ● Increase the acceleration time if the automatic restart after instantaneous power failure function or power failure stop function occurred during acceleration. | 6-151, 6-162 | |
| Load | Load is too heavy. | Reduce the load. | — |
| | Shaft is locked. | Inspect the machine (motor). | — |
| Others | Operation panel display shows an error (e.g. E.OC1). | When any fault occurs, take an appropriate corrective action, then reset the inverter, and resume the operation. | 7-2 |

7.6.2 Motor or machine generates abnormal noise

| Check points | Possible Cause | Countermeasures | Refer to page |
|-------------------|---|--|---------------|
| Input signal | Disturbance due to EMI when frequency command is given from analog input (terminal 2, 4). | Take countermeasures against EMI. | 3-38 |
| Parameter Setting | | Increase the Pr. 74 "Input filter time constant" if steady operation cannot be performed due to EMI. | 6-179 |
| Parameter Setting | No carrier frequency noises (metallic noises) are generated. | In the initial setting, Pr. 240 "Soft-PWM operation selection" is enabled to change motor noise to an unoffending complex tone. Therefore, no carrier frequency noises (metallic noises) are generated. Set Pr. 240 = "0" to disable this function. | 6-172 |
| | Resonance occurs. (output frequency) | Set Pr. 31 to Pr. 36 "Frequency jump". When it is desired to avoid resonance attributable to the natural frequency of a mechanical system, these parameters allow resonant frequencies to be jumped. | 6-52 |
| | Resonance occurs. (carrier frequency) | Change Pr. 72 "PWM frequency selection" setting. Changing the PWM carrier frequency produces an effect on avoiding the resonance frequency of a mechanical system or a motor. | 6-172 |
| | Auto tuning is not performed under Advanced magnetic flux vector control or General-purpose magnetic flux vector control. | Perform offline auto tuning. | 6-88 |
| | Gain adjustment during PID control is insufficient. | To stabilize the measured value, change the proportional band (Pr. 129) to a larger value, the integral time (Pr. 130) to a slightly longer time, and the differential time (Pr. 134) to a slightly shorter time. Check the calibration of set point and measured value. | 6-270 |
| Others | Mechanical looseness | Adjust machine/equipment so that there is no mechanical looseness. | — |
| Motor | Operating with output phase loss | Check the motor wiring. | — |
| | Contact the motor manufacturer. | | |

7.6.3 Inverter generates abnormal noise

| Check points | Possible Cause | Countermeasures | Refer to page |
|--------------|--|--------------------------------|---------------|
| Fan | Fan cover was not correctly installed when a cooling fan was replaced. | Install a fan cover correctly. | 8-6 |

7.6.4 Motor generates heat abnormally

| Check points | Possible Cause | Countermeasures | Refer to page |
|-------------------|---|---|---------------|
| Motor | Motor fan is not working (Dust is accumulated.) | Clean the motor fan. Improve the environment. | — |
| | Phase to phase insulation of the motor is insufficient. | Check the insulation of the motor. | — |
| Main Circuit | The inverter output voltage (U, V, W) are unbalanced. | Check the output voltage of the inverter. Check the insulation of the motor. | 8-2 |
| Parameter Setting | The Pr. 71 "Applied motor" setting is wrong. | Check the Pr. 71 "Applied motor" setting. | 6-85 |
| — | Motor current is large. | Refer to "7.6.11 Motor current is too large" | 7-27 |

7.6.5 Motor rotates in opposite direction

| Check points | Possible Cause | Countermeasures | Refer to page |
|-------------------|--|---|---------------|
| Main Circuit | Phase sequence of output terminals U, V and W is incorrect. | Connect phase sequence of the output cables (terminal U, V, W) to the motor correctly | 3-6 |
| Input signal | The start signals (forward rotation, reverse rotation) are connected improperly. | Check the wiring. (STF: forward rotation, STR: reverse rotation) | 3-14 |
| | Adjustment by the output frequency is improper during the reversible operation with Pr. 73 "Analog input selection" setting. | Check the setting of Pr. 125, Pr. 126, C2 to C7. | 6-85 |
| Parameter Setting | Pr. 40 "RUN key rotation direction selection" setting is incorrect. | Check the Pr. 40 setting. | 6-306 |

7.6.6 Speed greatly differs from the setting

| Check points | Possible Cause | Countermeasures | Refer to page |
|-------------------|---|--|---------------|
| Input signal | Frequency setting signal is incorrectly input. | Measure the input signal level. | — |
| | The input signal lines are affected by external EMI. | Take countermeasures against EMI such as using shielded wires for input signal lines. | 3-42 |
| Parameter Setting | Pr. 1, Pr. 2, Pr. 18, calibration parameter C2 to C7 settings are improper. | Check the settings of Pr. 1 "Maximum frequency", Pr. 2 "Minimum frequency", Pr. 18 "High speed maximum frequency". | 6-50 |
| | | Check the calibration parameter C2 to C7 settings. | 6-180 |
| | Pr. 31 to Pr. 36 "Frequency jump" settings are improper. | Narrow down the range of frequency jump. | 6-52 |
| Load | Stall prevention is activated due to a heavy load. | Reduce the load weight. | — |
| Parameter Setting | | Set Pr. 22 "Stall prevention operation level" higher according to the load. (Setting Pr. 22 too large may result in frequent over-current trip (E.OC□).) | 6-42 |
| Motor | | Check the capacities of the inverter and the motor. | — |

7.6.7 Acceleration/deceleration is not smooth

| Check points | Possible Cause | Countermeasures | Refer to page |
|---|---|--|---------------|
| Parameter Setting | Acceleration/deceleration time is too short. | Increase acceleration/deceleration time. | 6-69 |
| | Torque boost (Pr. 0, Pr. 46) setting is improper under V/f control, so the stall prevention function is activated. | Increase/decrease Pr. 0 "Torque boost" setting value by 0.5% increments to the setting. | 6-33 |
| | The base frequency does not match the motor characteristics. | For V/f control, set Pr. 3 "Base frequency" and Pr. 47 "Second V/f (base frequency)". | 6-54 |
| | | For Advanced magnetic flux vector control or General-purpose magnetic flux vector control, set Pr. 84 "Rated motor frequency". | 6-88 |
| | Stall prevention function is activated due to a heavy load. | Reduce the load weight. | — |
| | | Set Pr. 22 "Stall prevention operation level" higher according to the load. (Setting Pr. 22 too large may result in frequent over-current trip (E.OC□).) | 6-42 |
| | | Check the capacities of the inverter and the motor. | — |
| Regeneration avoidance operation is performed | If the frequency becomes unstable during regeneration avoidance operation, decrease the setting of Pr. 886 "Regeneration avoidance voltage gain". | 6-292 | |







7.6.8 Speed varies during operation

| Check points | Possible Cause | Countermeasures | Refer to page |
|-------------------|--|--|---------------|
| Input signal | Multi-speed command signal is chattering. | Take countermeasures to suppress chattering. | — |
| Load | Load varies during an operation. | Select Advanced magnetic flux vector control or General-purpose magnetic flux vector control. | 6-39 |
| Input signal | Frequency setting signal is varying. | Check the frequency reference signal. | — |
| | The frequency setting signal is affected by EMI. | Set filter to the analog input terminal using Pr. 74 "Input filter time constant". | 6-179 |
| | | Take countermeasures against EMI, such as using shielded wires for input signal lines. | 3-42 |
| | Malfunction is occurring due to the undesirable current generated when the transistor output unit is connected. | Use terminal PC (terminal SD when source logic) as a common terminal to prevent a malfunction caused by undesirable current. | 3-20 |
| Parameter Setting | Pr. 80 "Motor capacity" and Pr. 81 "Number of motor poles" setting is improper for the capacities of the inverter and the motor for Advanced magnetic flux vector control or General-purpose magnetic flux vector control. | Check the Pr. 80 "Motor capacity" and Pr. 81 "Number of motor poles" setting. | 6-39 |
| | Fluctuation of power supply voltage is too large. | Change the Pr. 19 "Base frequency voltage" setting (about 3%) under V/f control. | 6-54 |
| | Hunting occurs by the generated vibration, for example, when structural rigidity at load side is insufficient. | Disable automatic control functions, such as energy saving operation, fast-response current limit function, regeneration avoidance function, Advanced magnetic flux vector control, General-purpose magnetic flux vector control, and stall prevention. Adjust so that the control gain decreases and the level of safety increases. | — |
| | | Change Pr. 72 "PWM frequency selection" setting. | 6-172 |
| Others | Wiring length exceeds 30m when Advanced magnetic flux vector control or General-purpose magnetic flux vector control is performed. | Perform offline auto tuning. | 6-88 |
| | Wiring length is too long for V/f control, and a voltage drop occurs. | Adjust Pr. 0 Torque boost by increasing with 0.5% increments for low-speed operation. | 6-33 |
| | | Change to Advanced magnetic flux vector control or General-purpose magnetic flux vector control. | 6-39 |

7.6.9 Operation mode is not changed properly

| Check points | Possible Cause | Countermeasures | Refer to page |
|-------------------|--|--|---------------|
| Input signal | Start signal (STF or STR) is ON. | Check that the STF and STR signals are OFF. When either is ON, the operation mode cannot be changed. | 6-198 |
| Parameter Setting | Pr. 79 setting is improper. | When the Pr. 79 "Operation mode selection" setting is "0" (initial value), the inverter is placed in the external operation mode at input power-on. At this time, press the PU/EXT key on the operation panel (press the PU key when the parameter unit (FR-PU04/FR-PU07) is used) to switch to the PU operation mode. For other values (1 to 4, 6, 7), the operation mode is limited accordingly. | 6-198 |
| | Operation mode and a writing device do not correspond. | Check Pr. 79, Pr. 338, Pr. 339, Pr. 550, Pr. 551, and select an operation mode suitable for the purpose. | 6-198, 6-212 |

7.6.10 Operation panel display is not operating

| Check points | Possible Cause | Countermeasures | Refer to page |
|-------------------|---|---|---------------|
| Main Circuit | Wiring or installation is improper. | Check for the wiring and the installation. | 3-4 |
| | | Make sure that the connector is fitted securely across terminal + and P1. | |
| Control Circuit | Power is not input. | Input the power. | 3-4 |
| Parameter Setting | Command sources at the PU operation mode is not be the operation panel. (None of the operation mode displays (  ) is lit.) | Check the setting of Pr. 551 "PU mode operation command source selection". (If parameter unit (FR-PU04/FR-PU07) is connected while Pr. 551 = "9999" (initial setting), all the operation mode displays (  ) turn OFF.) | 6-212 |

7.6.11 Motor current is too large

| Check points | Possible Cause | Countermeasures | Refer to page |
|---|--|---|---------------|
| Parameter Setting | Torque boost (Pr. 0, Pr. 46) setting is improper under V/f control, so the stall prevention function is activated. | Increase/decrease Pr. 0 "Torque boost" setting value by 0.5% increments to the setting. | 6-33 |
| | V/f pattern is improper when V/f control is performed. (Pr. 3, Pr. 14, Pr. 19) | Set rated frequency of the motor to Pr. 3 "Base frequency". Use Pr. 19 "Base frequency voltage" to set the base voltage (e.g. rated motor voltage). | 6-54 |
| | | Change Pr. 14 "Load pattern selection" according to the load characteristic. | 6-56 |
| | Stall prevention function is activated due to a heavy load. | Reduce the load weight. | — |
| | | Set Pr. 22 "Stall prevention operation level" higher according to the load. (Setting Pr. 22 too large may result in frequent overcurrent trip (E.OC□).) | 6-42 |
| | | Check the capacities of the inverter and the motor. | — |
| Auto tuning is not performed under Advanced magnetic flux vector control or General-purpose magnetic flux vector control. | Perform offline auto tuning. | 6-88 | |

7.6.12 Speed does not accelerate

| Check points | Possible Cause | Countermeasures | Refer to page |
|---|--|--|---------------|
| Input signal | Start command and frequency command are chattering. | Check if the start command and the frequency command are correct. | — |
| | The wiring length used for analog frequency command is too long, and it is causing a voltage (current) drop. | Perform analog input bias/gain calibration. | 6-180 |
| | Input signal lines are affected by external EMI. | Take countermeasures against EMI, such as using shielded wires for input signal lines. | 3-42 |
| Parameter Setting | Pr. 1, Pr. 2, Pr. 18, calibration parameter C2 to C7 settings are improper. | Check the settings of Pr. 1 "Maximum frequency" and Pr. 2 "Minimum frequency". If you want to run the motor at 120Hz or higher, set Pr. 18 "High speed maximum frequency". | 6-50 |
| | | Check the calibration parameter C2 to C7 settings. | 6-180 |
| | Torque boost (Pr. 0, Pr. 46) setting is improper under V/f control, so the stall prevention function is activated. | Increase/decrease Pr. 0 "Torque boost" setting value by 0.5% increments so that stall prevention does not occur. | 6-33 |
| | V/f pattern is improper when V/f control is performed. (Pr. 3, Pr. 14, Pr. 19) | Set rated frequency of the motor to Pr. 3 "Base frequency". Use Pr. 19 "Base frequency voltage" to set the base voltage (e.g. rated motor voltage). | 6-54 |
| | | Change Pr. 14 "Load pattern selection" according to the load characteristic. | 6-56 |
| | Stall prevention is activated due to a heavy load. | Reduce the load weight. | — |
| | | Set Pr. 22 "Stall prevention operation level" higher according to the load. (Setting Pr. 22 too large may result in frequent overcurrent trip (E.O.C□).) | 6-42 |
| | | Check the capacities of the inverter and the motor. | — |
| Auto tuning is not performed under Advanced magnetic flux vector control or General-purpose magnetic flux vector control. | Perform offline auto tuning. | 6-88 | |
| During PID control, output frequency is automatically controlled to make measured value = set point. | | 6-270 | |
| Main Circuit | Brake resistor is connected between terminal + and P1 or between terminal P1 and PR by mistake. | Connect an optional brake transistor (MRS type, FR-ABR) between terminal + and PR. | 3-28 |

7.6.13 Unable to write parameter setting

| Check points | Possible Cause | Countermeasures | Refer to page |
|-------------------|--|---|---------------|
| Input signal | Operation is being performed (signal STF or STR is ON). | Stop the operation. When Pr. 77 = "0" (initial value), write is enabled only during a stop. | 6-192 |
| Parameter Setting | You are attempting to set the parameter in the External operation mode. | Choose the PU operation mode. Or, set Pr. 77 = "2" to enable parameter write regardless of the operation mode. | 6-192 |
| | Parameter is disabled by the Pr. 77 "Parameter write selection" setting. | Check Pr. 77 "Parameter write selection" setting. | 6-192 |
| | Key lock is activated by the Pr. 161 "Frequency setting/key lock operation selection" setting. | Check Pr. 161 "Frequency setting/key lock operation selection" setting. | 6-307 |
| | Operation mode and a writing device do not correspond. | Check Pr. 79, Pr. 338, Pr. 339, Pr. 550, Pr. 551, and select an operation mode suitable for the purpose. | 6-198, 6-212 |

7.7 Meters and measuring methods

NOTE

For further information about measurements at the inverter refer to section 8.2.

Since voltages and currents in the primary and secondary side of the inverter include harmonics, different meters indicate different measured values. When making measurement with the meters designed for commercial frequency, use the following measuring instruments and circuits:

When installing meters etc. on the inverter output side

When the inverter-to-motor wiring length is large, especially in the 400V class, large-capacity models, the meters and CTs may generate heat due to line-to-line leakage current. Therefore, choose the equipment which has enough allowance for the current rating. When measuring and indicating the output voltage and output current of the inverter, it is recommended to utilize the AM-5 terminal output function of the inverter.

When using measuring instruments for the normal frequency range, carry out the measurements as described below.

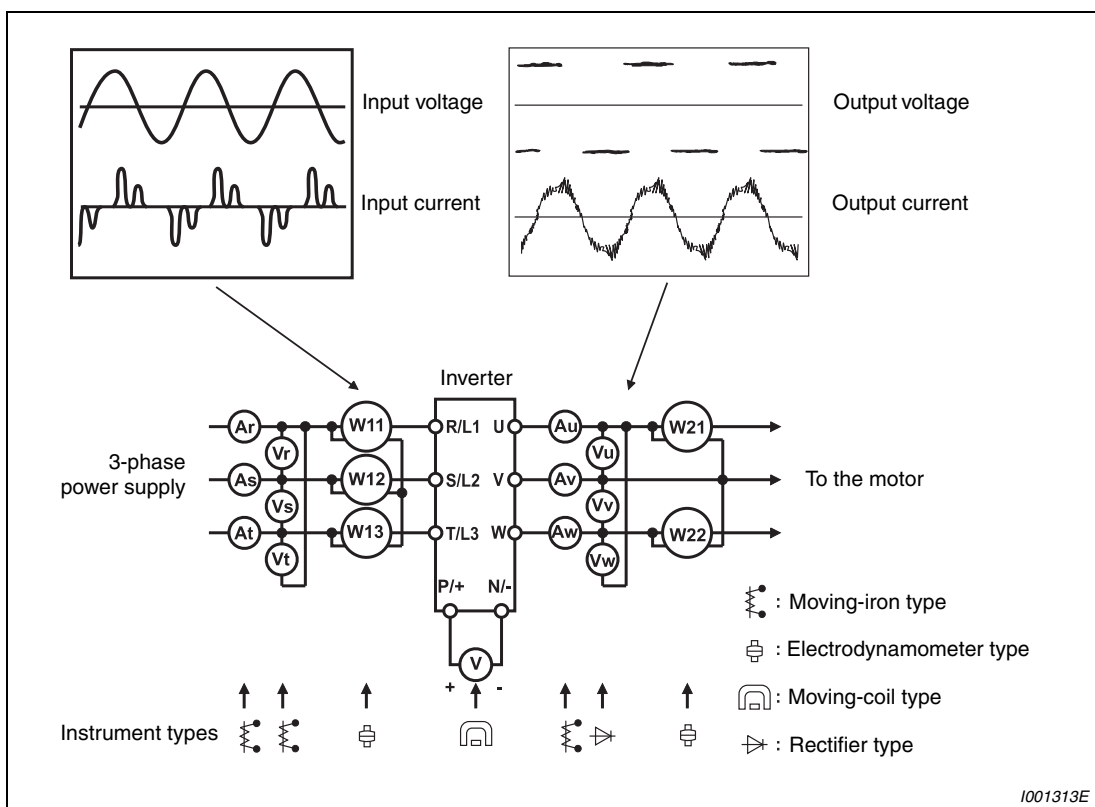

Fig. 7-7: Measurements at the main circuit

7.7.1 Measurement of powers

Using an electro-dynamometer type meter, measure the power in both the input and output sides of the inverter using the two- or three-wattmeter method. As the current is liable to be imbalanced especially in the input side, it is recommended to use the three-wattmeter method. Examples of measured value differences produced by different measuring meters are shown below.

An error will be produced by difference between measuring instruments, e.g. power calculation type and two- or three-wattmeter type three-phase wattmeter. When a CT is used in the current measuring side or when the meter contains a PT on the voltage measurement side, an error will also be produced due to the frequency characteristics of the CT and PT.

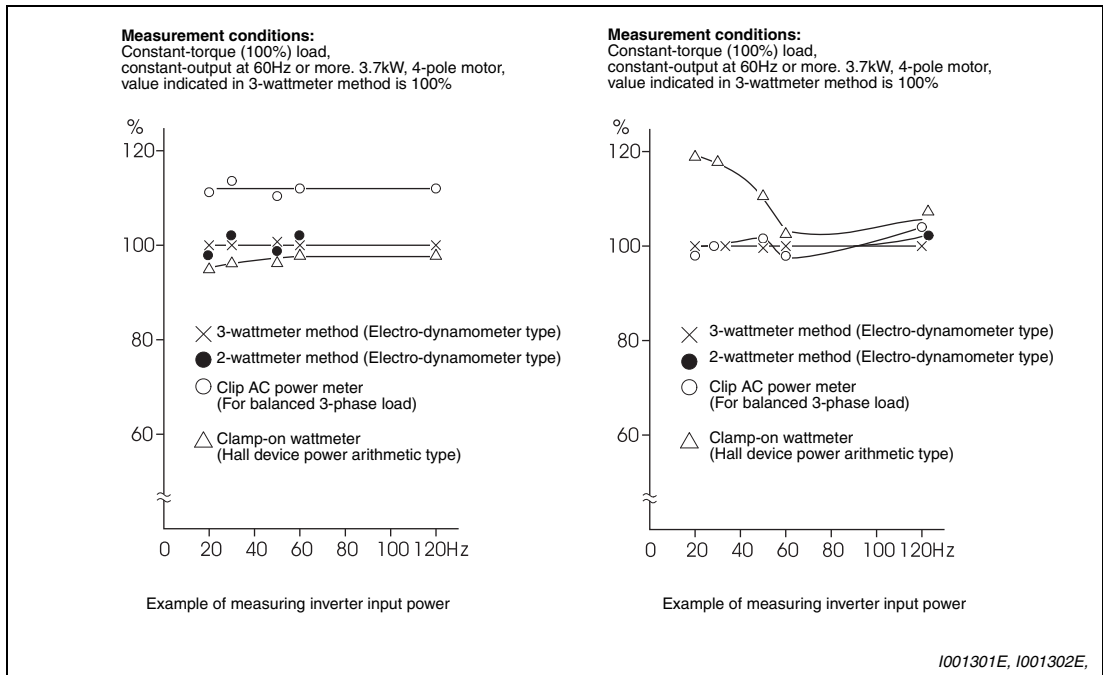

Fig. 7-8: Differences when measuring power with different instruments

7.7.2 Measurement of voltages and use of PT

Inverter input side

As the input side voltage has a sine wave and it is extremely small in distortion, accurate measurement can be made with an ordinary AC meter.

Inverter output side

Since the output side voltage has a PWM-controlled rectangular wave, always use a rectifier type voltmeter. A needle type tester can not be used to measure the output side voltage as it indicates a value much greater than the actual value. A moving-iron type meter indicates an effective value which includes harmonics and therefore the value is larger than that of the fundamental wave. The value monitored on the operation panel is the inverter-controlled voltage itself. Hence, that value is accurate and it is recommended to monitor values (provide analog output) using the operation panel.

PT

No PT can be used in the output side of the inverter. Use a direct-reading meter. (A PT can be used in the input side of the inverter.)

7.7.3 Measurement of currents

Use a moving-iron type meter on both the input and output sides of the inverter. However, if the carrier frequency exceeds 5kHz, do not use that meter since an overcurrent losses produced in the internal metal parts of the meter will increase and the meter may burn out. In this case, use an approximate-effective value type.

Since current on the inverter input side tends to be unbalanced, measurement of three phases is recommended. Correct value can not be obtained by measuring only one or two phases. On the other hand, the unbalanced ratio of each phase of the output side current should be within 10%.

When a clamp ammeter is used, always use an effective value detection type. A mean value detection type produces a large error and may indicate an extremely smaller value than the actual value. The value monitored on the operation panel is accurate if the output frequency varies, and it is recommended to monitor values (provide analog output) using the operation panel.

Examples of process value differences produced by different measuring meters are shown below.

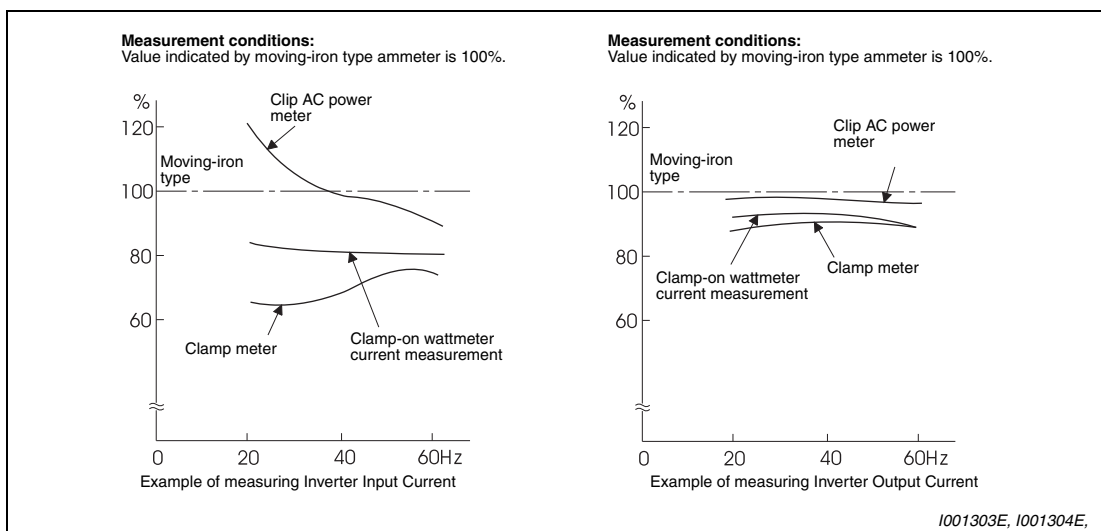

Fig. 7-9: Differences when measuring currents with different instruments

7.7.4 Use of CT and transducer

A CT may be used in both the input and output sides of the inverter, but the one used should have the largest possible VA ability because an error will increase if the frequency gets lower. When using a transducer, use the effective value calculation type which is immune to harmonics.

7.7.5 Measurement of inverter input power factor

Use the effective power and apparent power to calculate the inverter input power factor. A power-factor meter cannot indicate an exact value.

$$\begin{aligned} \text{Total power factor of the inverter} &= \frac{\text{Effective power}}{\text{Apparent power}} \\ &= \frac{\text{3-phase input power found by 3-wattmeter method}}{\sqrt{3} \times V \text{ (power supply voltage)} \times I \text{ (input current effective value)}} \end{aligned}$$

7.7.6 Measurement of converter output voltage (across terminals + and –)

The output voltage of the converter is developed across terminals + and – and can be measured with a moving-coil type meter (tester). Although the voltage varies according to the power supply voltage, approximately 270V DC to 300V DC (540V DC to 600V DC for the 400V class) is output when no load is connected and voltage decreases during driving load operation.

When energy is regenerated from the motor during deceleration, for example, the converter output voltage rises to nearly 400V DC to 450V DC (800V DC to 900V DC for the 400V class) maximum. When this value is reached the alarm message E.OV□ is displayed and the inverter output is shut off.

8 Maintenance and inspection

The inverter is a static unit mainly consisting of semiconductor devices. Daily inspection must be performed to prevent any fault from occurring due to the adverse effects of the operating environment, such as temperature, humidity, dust, dirt and vibration, changes in the parts with time, service life, and other factors.

**WARNING:**

Wait for a period of well over 10 minutes after disconnecting from the power supply before performing any service work on the frequency inverter. This is necessary so that the capacitors can discharge down to a safe level (< 25V) after disconnection of the mains power. Check the voltage across the main circuit terminals + and – of the inverter using a tester.

8.1 Inspection

8.1.1 Daily inspection

Basically, check for the following faults during operation:

- Motor operation fault
- Improper installation environment
- Cooling system fault
- Unusual vibration and noise
- Unusual overheat and discoloration

During operation, check the inverter input voltages using a tester.

8.1.2 Periodic inspection

Check the areas inaccessible during operation and requiring periodic inspection. Consult us for periodic inspection.

- Check for cooling system fault Clean the air filter, etc.
- Tightening check and retightening The screws and bolts may become loose due to vibration, temperature changes, etc.
Tighten them according to the specified tightening torque. (Refer to page 3-9.)
- Check the conductors and insulating materials for corrosion and damage.
- Measure insulation resistance.
- Check and change the cooling fan and relay.

8.1.3 Daily and periodic inspection

| Area of Inspection | Inspection Item | Description | Interval | | Corrective Action at Alarm Occurrence | Customer's check | |
|--------------------|---|---|--|------------------|--|--|--|
| | | | Daily | Periodic ② | | | |
| General | Surrounding environment | Check the ambient temperature, humidity, dirt, corrosive gas, oil mist, etc. | ✓ | | Improve environment | | |
| | Overall unit | Check for unusual vibration and noise. | ✓ | | Check alarm location and retighten | | |
| | Power supply voltage | Check that the main circuit voltages are normal. ① | ✓ | | Inspect the power supply | | |
| Main circuit | General | 1) Check with megger (across main circuit terminals and earth (ground) terminal). 2) Check for loose screws and bolts. 3) Check for overheat traces on the parts. 4) Check for stain | | ✓ ✓ ✓ ✓ | Contact the manufacturer Retighten Contact the manufacturer Clean | | |
| | Conductors, cables | 1) Check conductors for distortion. 2) Check cable sheaths for breakage | | ✓ ✓ | Contact the manufacturer Contact the manufacturer | | |
| | Transformer/reactor | Check for unusual odor and abnormal increase in whining sound. | ✓ | | Stop the device and contact the manufacturer. | | |
| | Terminal block | Check for damage. | | ✓ | Stop the device and contact the manufacturer. | | |
| | Smoothing aluminum electrolytic capacitor | 1) Check for liquid leakage. 2) Check for safety valve projection and bulge. 3) Visual check and judge by the life check of the main circuit capacitor (Refer to section 8.1.4.) | | ✓ ✓ ✓ | Contact the manufacturer Contact the manufacturer | | |
| | Relay/contacter | Check that the operation is normal and no chatter is heard. | | ✓ | Contact the manufacturer | | |
| | Control circuit/Protective circuit | Operation check | 1) Check that the output voltages across phases with the inverter operated alone is balanced. 2) Check that no fault is found in protective and display circuits in a sequence protective operation test. | | ✓ ✓ | Contact the manufacturer Contact the manufacturer | |
| Parts check | | Overall | 1) Check for unusual odor and discoloration. 2) Check for serious rust development. | | ✓ ✓ | Stop the device and contact the manufacturer Contact the manufacturer | |
| | | Aluminum electrolytic capacitor | 1) Check for liquid leakage in a capacitor and deformation trace 2) Visual check and judge by the life check of the control circuit capacitor. (Refer to section 8.1.4.) | | ✓ ✓ | Contact the manufacturer | |
| Cooling system | Cooling fan | 1) Check for unusual vibration and noise. 2) Check for loose screws and bolts. 3) Check for stain. | ✓ | ✓ ✓ ✓ | Replace the fan Retighten Clean | | |
| | Heatsink | 1) Check for clogging. 2) Check for stain. | | ✓ ✓ | Clean Clean | | |

Tab. 8-1: Daily and periodic inspection (1)

| Area of Inspection | Inspection Item | Description | Interval | | Corrective Action at Alarm Occurrence | Customer's check |
|--------------------|-----------------|---|----------|------------|---|------------------|
| | | | Daily | Periodic ② | | |
| Display | Indication | 1) Check that display is normal. | ✓ | | Contact the manufacturer | |
| | | 2) Check for stain. | | ✓ | Clean | |
| | Meter | Check that reading is normal. | ✓ | | Stop the device and contact the manufacturer. | |
| Load motor | Operation check | Check for vibration and abnormal increase in operation noise. | ✓ | | Stop the device and contact the manufacturer. | |

Tab. 8-1: *Daily and periodic inspection (2)*

- ① It is recommended to install a device to monitor voltage for checking the power supply voltage to the inverter.
- ② One to two years of periodic inspection cycle is recommended. However, it differs according to the installation environment. Consult us for periodic inspection.

8.1.4 Display of the life of the inverter parts

The self-diagnostic alarm is output when the life span of the control circuit capacitor, cooling fan and each parts of the inrush current limit circuit is near to give an indication of replacement time.

For the life check of the main circuit capacitor, the alarm signal (Y90) will not be output if a measuring method using Parameter 259 is not performed. (Refer to the description below.)

The life alarm output can be used as a guideline for life judgement:

| Parts | Judgement Level |
|------------------------------|---|
| Main circuit capacitor | 85% of the initial capacity |
| Control circuit capacitor | Estimated 10% life remaining |
| Inrush current limit circuit | Estimated 10% life remaining (Power on: 100,000 times left) |
| Cooling fan | Less than 50% of the predetermined speed |

Tab. 8-2: Guideline for the alarm signal output

NOTE

Refer to section 6.21.2 to perform the life check of the inverter parts.

8.1.5 Checking the inverter and converter modules

Disconnect the external power supply cables (R/L1, S/L2, T/L3) and motor cables (U, V, W). Prepare a tester. (Use 100Ω range.)

Change the polarity of the tester alternately at the inverter terminals R/L1, S/L2, T/L3, U, V, W, + and –, and check for continuity.



CAUTION:
Before measurement, check that the smoothing capacitor is discharged.

At the time of discontinuity, the measured value is almost ∞. When there is an instantaneous continuity, due to the smoothing capacitor, the tester may not indicate ∞. At the time of continuity, the measured value is several to several ten's-of ohms depending on the module type, circuit tester type, etc. If all measured values are almost the same, the modules are without fault.

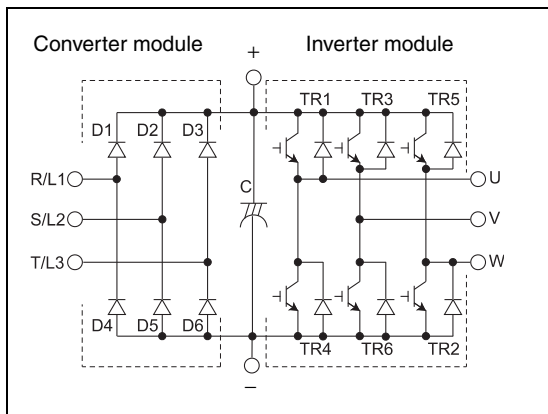

Fig. 8-1:
 Module device numbers and terminals to be checked

1002039E

| | | Tester Polarity | | Measured Value | | | Tester Polarity | | Measured Value |
|------------------|------|-----------------|--------|----------------|------|--------|-----------------|---------------|----------------|
| | | ⊕ | ⊖ | | | | ⊕ | ⊖ | |
| Converter module | D1 | R/L1 | + | Discontinuity | D4 | R/L1 | - | Continuity | |
| | | + | R/L1 | Continuity | | - | R/L1 | Discontinuity | |
| | D2 | S/L2 | + | Discontinuity | D5 | S/L2 | - | Continuity | |
| | | + | S/L2 | Continuity | | - | S/L2 | Discontinuity | |
| | D3 ① | T/L3 ① | + | Discontinuity | D6 ① | T/L3 ① | - | Continuity | |
| | | + | T/L3 ① | Continuity | | - | T/L3 ① | Discontinuity | |
| Inverter module | TR1 | U | + | Discontinuity | TR4 | U | - | Continuity | |
| | | + | U | Continuity | | - | U | Discontinuity | |
| | TR3 | V | + | Discontinuity | TR6 | V | - | Continuity | |
| | | + | V | Continuity | | - | V | Discontinuity | |
| | TR5 | W | + | Discontinuity | TR2 | W | - | Continuity | |
| | | + | W | Continuity | | - | W | Discontinuity | |

Tab. 8-3: Continuity check of the modules

① T/L3, D3 and D6 are only for the three-phase power input specification models.

8.1.6 Cleaning

Always run the inverter in a clean status. When cleaning the inverter, gently wipe dirty areas with a soft cloth immersed in neutral detergent or ethanol.



CAUTION:

Do not use solvent, such as acetone, benzene, toluene and alcohol, as they will cause the inverter surface paint to peel off.

The display, etc. of the operation panel and parameter unit (FR-PU04/FR-PU07) are vulnerable to detergent and alcohol. Therefore, avoid using them for cleaning.

8.1.7 Replacement of parts

The inverter consists of many electronic parts such as semiconductor devices. The following parts may deteriorate with age because of their structures or physical characteristics, leading to reduced performance or fault of the inverter. For preventive maintenance, the parts must be replaced periodically.

Use the life check function as a guidance of parts replacement.

| Part Name | Standard Replacement Interval ^① | Description |
|----------------------------------|--|---------------------------------|
| Cooling fan | 10 years | Replace (as required) |
| Main circuit smoothing capacitor | 10 years ^② | Replace (as required) |
| On-board smoothing capacitor | 10 years | Replace the board (as required) |
| Relays | — | As required |

Tab. 8-4: Wearing parts

- ① Replacement years for when the yearly average ambient temperature is 40°C (without corrosive gas, flammable gas, oil mist, dust and dirt etc.)
- ② Output current: 80% of the inverter rated current

NOTE

For parts replacement, consult the nearest Mitsubishi FA Centre.

Cooling fan

The replacement interval of the cooling fan used for cooling the parts generating heat such as the main circuit semiconductor is greatly affected by the ambient temperature. When unusual noise and/or vibration is noticed during inspection, the cooling fan must be replaced immediately.

| Inverter Type | Fan Type | Units | |
|---------------|-------------|-------------------------------|---|
| FR-E720S- | 50 to 110 | MMF-06F24ES-RP1 BKO-CA1638H01 | 1 |
| | 040 to 095 | MMF-06F24ES-RP1 BKO-CA1638H01 | 1 |
| FR-E740- | 120 and 170 | MMF-06F24ES-RP1 BKO-CA1638H01 | 2 |
| | 230 and 300 | MMF-08F24ES-RP1 BKO-CA1639H01 | 2 |

Tab. 8-5: Correspondence between inverters and cooling fans

NOTE

The FR-E720S-030 or less and the FR-E740-026 or less are not provided with a cooling fan.



WARNING:

Switch the power off before replacing fans. Since the inverter circuits are charged with voltage even after power off, replace fans only when the inverter cover is on the inverter to prevent an electric shock accident.

● Removal of the fan

- ① Push the hooks of the fan cover from above. Remove the fan cover.

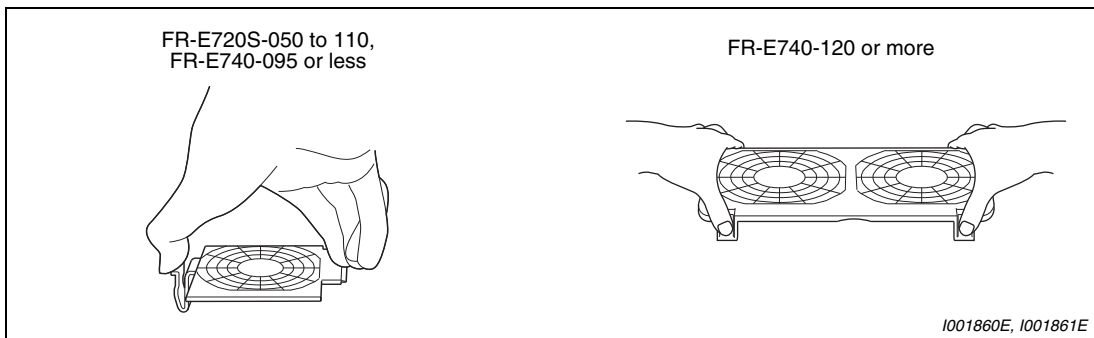

Fig. 8-2: Removal of the fan cover

- ② Disconnect the fan connector.
- ③ Remove the fan.

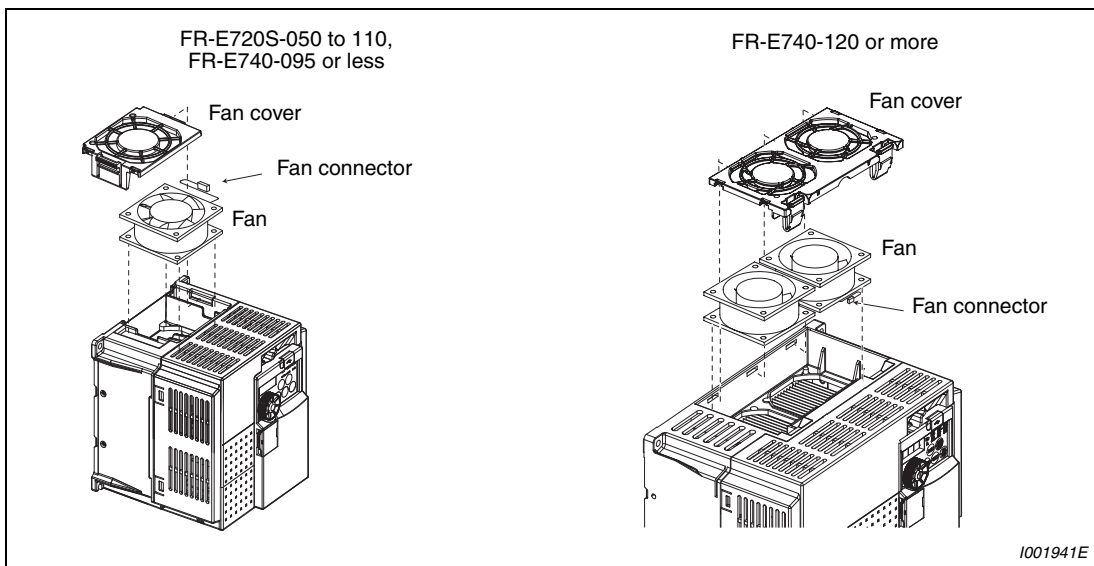

Fig. 8-3: Removal of the fan

● Reinstallation of the fan

- ① After confirming the orientation of the fan, reinstall the fan so that the arrow on the left of "AIR FLOW" faces up.

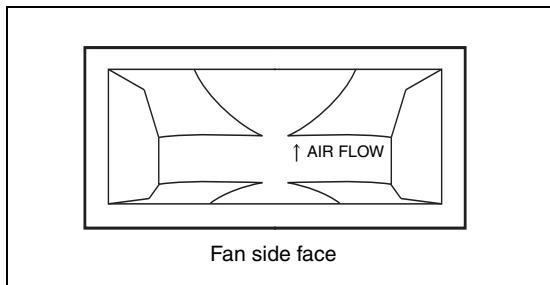

Fig. 8-4:
Orientation of the fan

I001864E

NOTE

Installing the fan in the opposite air flow direction can cause the inverter life to be shorter.

- ② Reconnect the fan connectors. When wiring, use care to avoid the cables being caught by the fan.

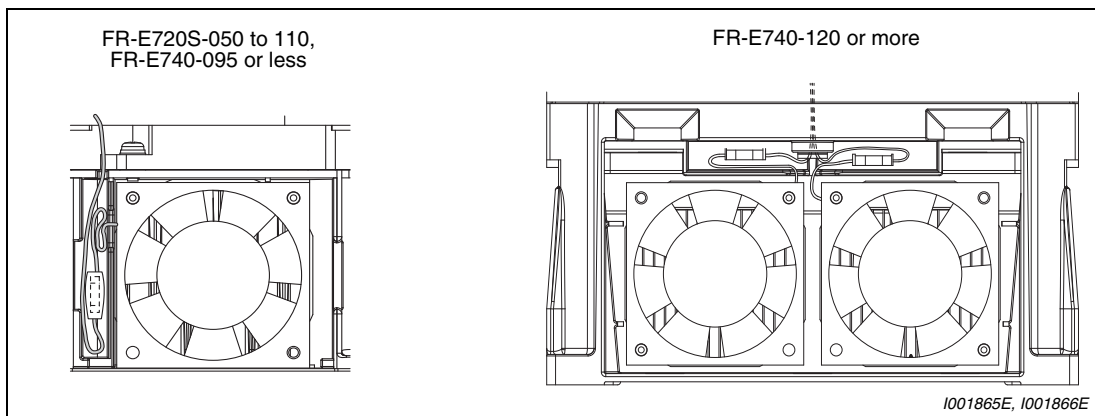

Fig. 8-5: Connection of the fan

- ③ Reinstall the fan cover. Insert hooks ① into the holes. Insert hooks ② until you hear a click sound.

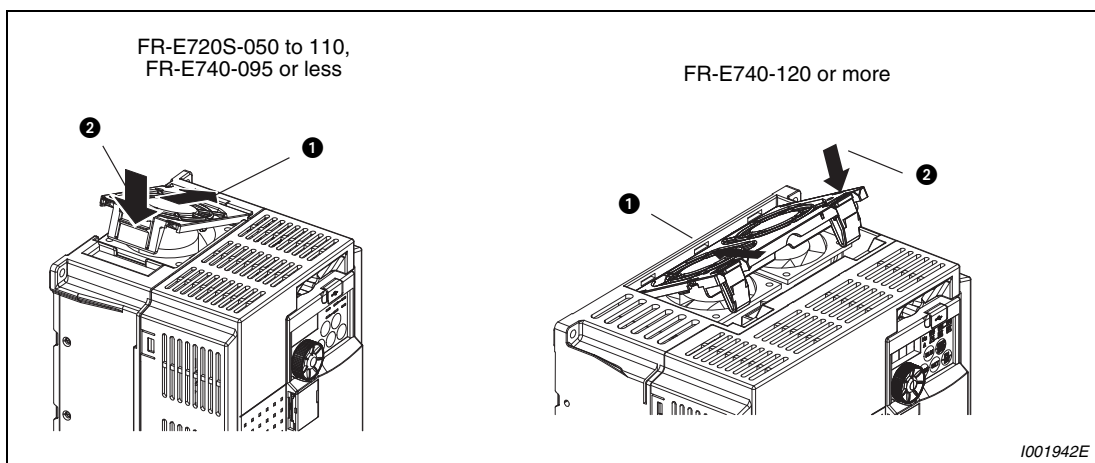

Fig. 8-6: Reinstall the fan cover

Smoothing capacitors

A large-capacity aluminum electrolytic capacitor is used for smoothing in the main circuit DC section, and an aluminum electrolytic capacitor is used for stabilizing the control power in the control circuit. Their characteristics are deteriorated by the adverse effects of ripple currents, etc.

The replacement intervals greatly vary with the ambient temperature and operating conditions. When the inverter is operated in air-conditioned, normal environment conditions, replace the capacitors about every 10 years

Judge that the capacitor has reached its life when the measured capacitance of the capacitor reduced below 80% of the rating.

When a certain period of time has elapsed, the capacitors will deteriorate more rapidly. Check the capacitors at least every year (less than six months if the life will be expired soon).

The appearance criteria for inspection are as follows:

- Case: Check the side and bottom faces for expansion
- Sealing plate: Check for remarkable warp and extreme crack.
- Check for external crack, discoloration, fluid leakage, etc.

Relays

To prevent a contact fault, etc., relays must be replaced according to the cumulative number of switching times (switching life).

8.1.8 Inverter replacement

The inverter can be replaced with the control circuit wiring kept connected. Before replacement, remove the wiring cover of the inverter.



WARNING:

Before starting inverter replacement, switch power off, wait for at least 10 minutes, and then check the voltage with a tester and such to ensure safety.

- ① Remove the installation screw of the control circuit terminal block.
Pull the control circuit terminal downward.

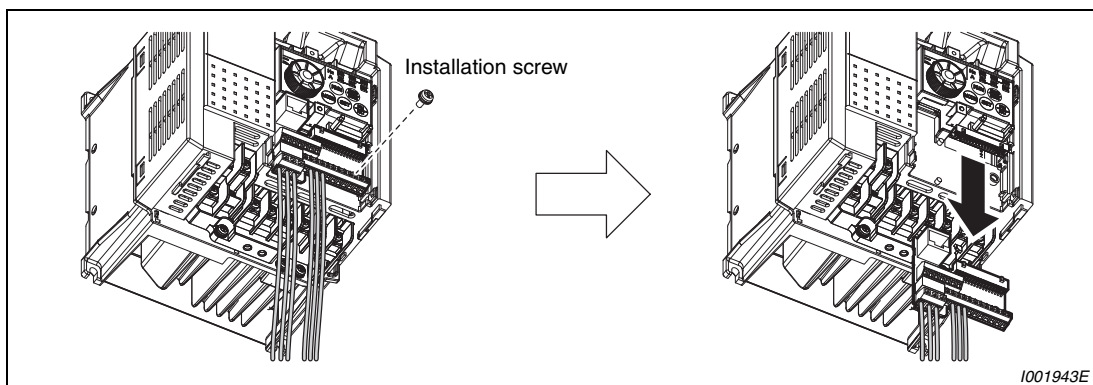

Fig. 8-7: Removal of the terminal block

- ② Using care not to bend the pins of the inverter's control circuit connector, reinstall the control circuit terminal block and fix it with the installation screw.

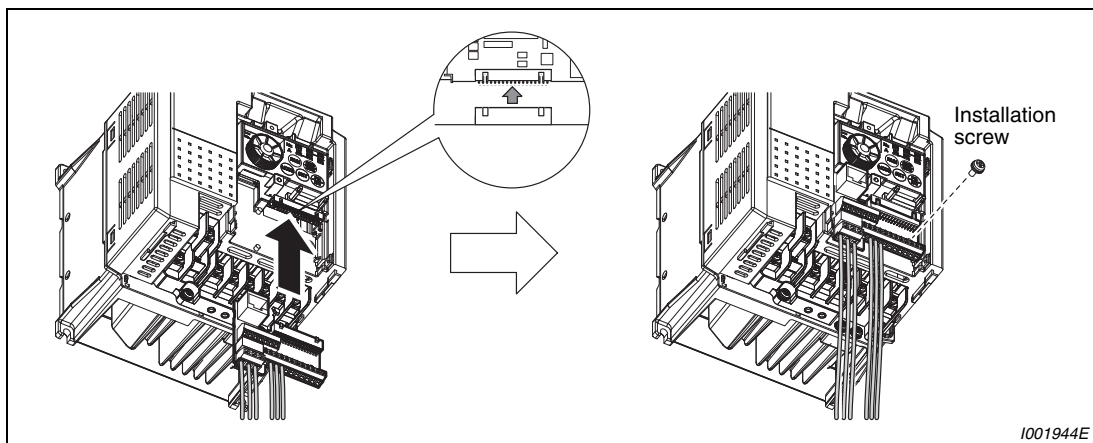

Fig. 8-8: Reinstallation of the terminal block

NOTE

Calibration bias and gain changes when changing the control circuit terminal block. Use Pr. 645 and C1 (Pr. 901) to calibrate again in that case.

8.2 Measurements on the main circuit

This section describes the measurement of the main circuit voltages, currents, powers and insulation resistance.

Please follow as well the instructions for measuring instruments and measuring methods in section 7.7.

8.2.1 Insulation resistance test using megger

For the inverter, conduct the insulation resistance test on the main circuit only as shown below and do not perform the test on the control circuit. (Use a 500V DC megger.)

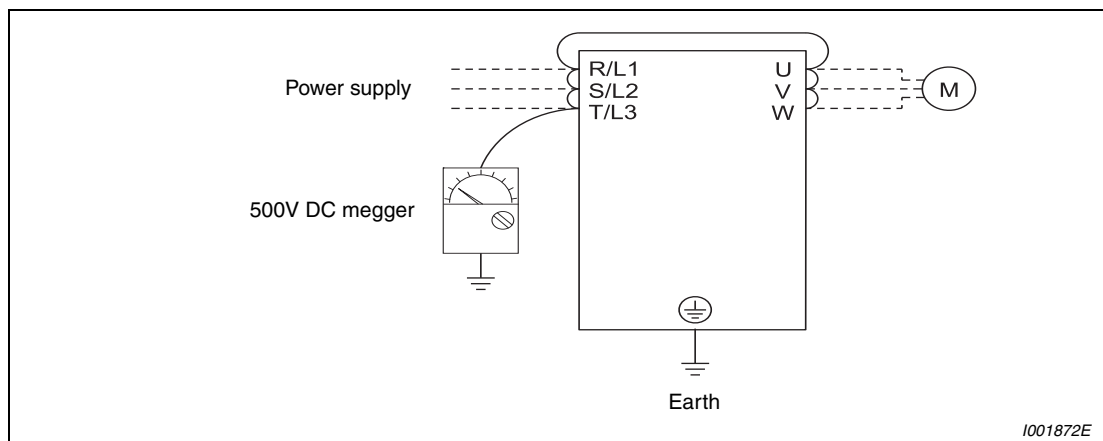

Fig. 8-9: Insulation resistance test



CAUTION:

Before performing the insulation resistance test on the external circuit, disconnect the cables from all terminals of the inverter so that the test voltage is not applied to the inverter.

NOTE

For the continuity test of the control circuit, use a tester (high resistance range) and do not use the megger or buzzer.

8.2.2 Pressure test

Do not conduct a pressure test. Deterioration may occur.

8.2.3 Measurement of voltages and currents

Since voltages and currents in the primary and secondary side of the inverter include harmonics, different meters indicate different measured values. When making measurement with the meters designed for commercial frequency, use the following measuring instruments and circuits:

When installing meters etc. on the inverter output side

When the inverter-to-motor wiring length is large, especially in the 400V class, large-capacity models, the meters and CTs may generate heat due to line-to-line leakage current. Therefore, choose the equipment which has enough allowance for the current rating. When measuring and indicating the output voltage and output current of the inverter, it is recommended to utilize the AM-5 terminal output function of the inverter.

When using measuring instruments for the normal frequency range, carry out the measurements as described below.

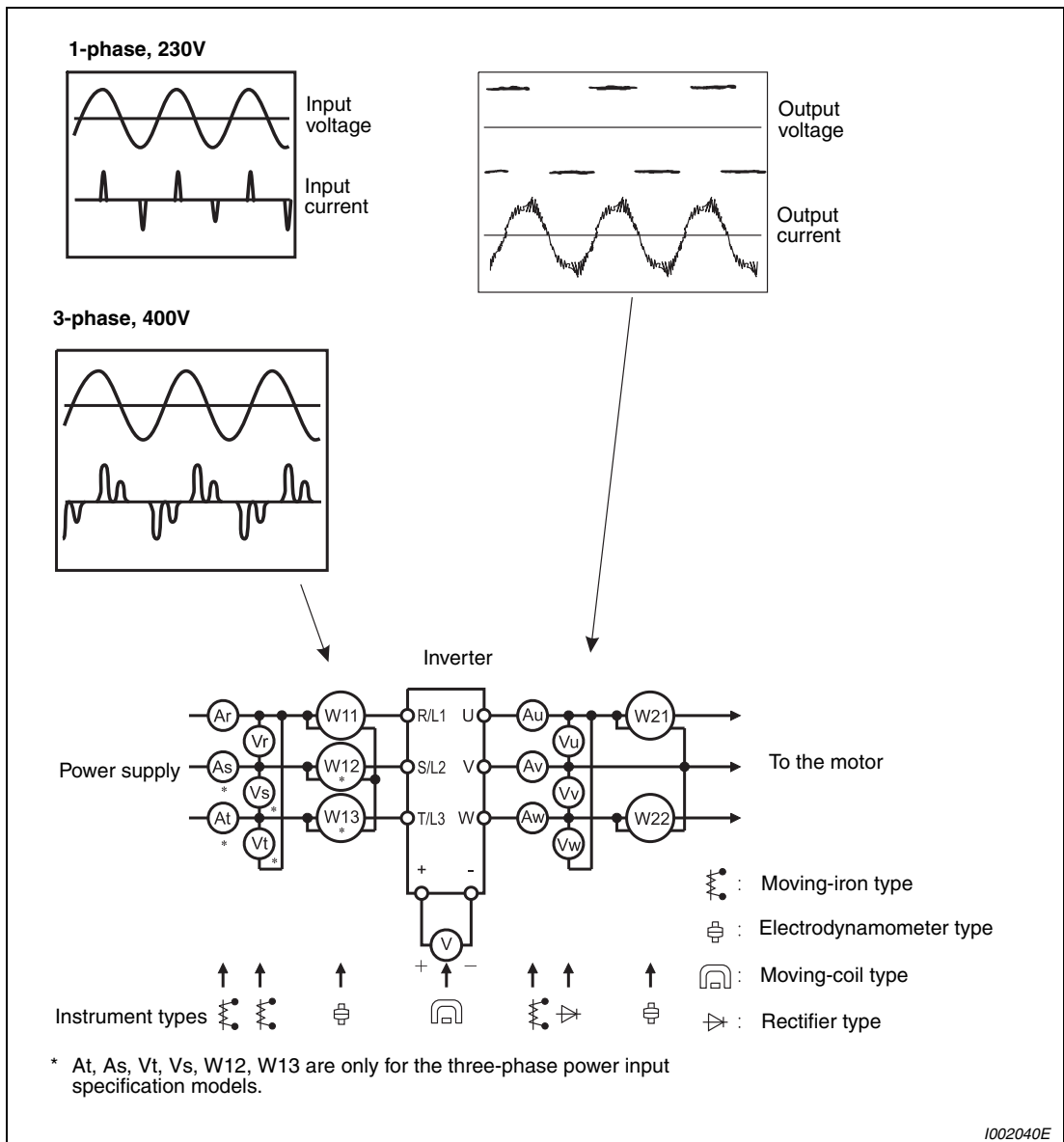

Fig. 8-10: Examples of measuring points and instruments

Measuring Points and Instruments

| Item | Measuring Point | Measuring Instrument | Remarks (Reference Measurement Value) |
|------------------------------------|--|---|--|
| Power supply voltage V1 | Across R/L1-S/L2, S/L2-T/L3, T/L3-R/L1 ③ | Moving-iron type AC voltmeter | Commercial power supply Within permissible AC voltage fluctuation (Refer to appendix A) |
| Power supply side current I1 | R/L1, S/L2, and T/L3 line currents ③ | Moving-iron type AC ammeter | — |
| Power supply side power P1 | R/L1, S/L2, T/L3 and R/L1-S/L2, S/L2-T/L3, T/L3-R/L1 ③ | Electrodynamic type single-phase wattmeter | P1 = W11 + W12 + W13 (3-wattmeter method) |
| Power supply side power factor Pf1 | Calculate after measuring power supply voltage, power supply side current and power supply side power. Single-phase power supply $Pf1 = \frac{P1}{V1 \times I1} \times 100 \%$ Three-phase power supply $Pf1 = \frac{P1}{\sqrt{3} \times V1 \times I1} \times 100 \%$ | | |
| Output side voltage V2 | Across U-V, V-W and W-U | Rectifier type AC voltage meter ① (Moving-iron type cannot measure) | Difference between the phases is within ±1% of the maximum output voltage |
| Output side current I2 | U, V and W line currents | Moving-iron type AC ammeter ② | Difference between the phases is 10% or lower of the rated inverter current. |
| Output side power P2 | U, V, W and U-V, V-W | Electrodynamic type single-phase wattmeter | P2 = W21 + W22 2-wattmeter method (or 3-wattmeter method) |
| Output side power factor Pf2 | Calculate in similar manner to power supply side power factor. $Pf2 = \frac{P2}{\sqrt{3} \times V2 \times I2} \times 100\%$ | | |
| Converter output | Across + and – | Moving-coil type (such as tester) | Inverter LED display is lit. 1.35 × V1 |

Tab. 8-6: Measuring Points and Instruments of the main circuit

- ① Use an FFT to measure the output voltage accurately. An FA tester or general measuring instrument cannot measure accurately.
- ② When the carrier frequency exceeds 5kHz, do not use this instrument since using it may increase eddy-current losses produced in metal parts inside the instrument, leading to burnout. In this case, use an approximate-effective value type.
- ③ T/L3 is only for the three-phase power input specification models.

| Item | Measuring Point | Measuring Instrument | Remarks (Reference Measurement Value) | | | | | | | | | | |
|--------------------------------|---|--|--|---------------|----------------|---------------|-----------------|------------|---------------|------------|------------|------------|---------------|
| Frequency setting signal | Across 2 (positive) and 5 | Moving-coil type (Tester and such may be used) (Internal resistance: 50kΩ or larger) | 0 to 10V DC, 4 to 20mA | "5" is common | | | | | | | | | |
| | Across 4 (positive) and 5 | | | | | | | | | | | | |
| Frequency setting power supply | Across 10 (positive) and 5 | | 5.2V DC | | | | | | | | | | |
| Frequency meter signal | Across AM (positive) and 5 | | Approximately 10V DC at maximum frequency (without frequency meter) | | | | | | | | | | |
| Start signal Select signal | Across STF, STR, RH, RM, RL and PC (positive) | | When open: 20 to 30V DC ON voltage: 1V or less | | "PC" is common | | | | | | | | |
| Reset | Across RES and PC (positive) | | | | | | | | | | | | |
| Output stop | Across MRS and PC (positive) | | | | | | | | | | | | |
| Fault signal | Across A-C and B-C | Moving-coil type (such as tester) | Continuity check ① <table style="width: 100%; border: none;"> <tr> <td style="width: 33%;"></td> <td style="text-align: center;">Normal</td> <td style="text-align: center;">Abnormal</td> </tr> <tr> <td>Across A-C</td> <td style="text-align: center;">Discontinuity</td> <td style="text-align: center;">Continuity</td> </tr> <tr> <td>Across B-C</td> <td style="text-align: center;">Continuity</td> <td style="text-align: center;">Discontinuity</td> </tr> </table> | | | Normal | Abnormal | Across A-C | Discontinuity | Continuity | Across B-C | Continuity | Discontinuity |
| | Normal | Abnormal | | | | | | | | | | | |
| Across A-C | Discontinuity | Continuity | | | | | | | | | | | |
| Across B-C | Continuity | Discontinuity | | | | | | | | | | | |

Tab. 8-6: *Measuring Points and Instruments of the control circuit*

① When the setting of Pr. 192 "ABC terminal function selection" is positive logic.

A Appendix

A.1 Specifications

A.1.1 1-phase, 200V class

| Model FR-E720S-□□□-EC | | 008 | 015 | 030 | 050 | 080 | 110 |
|-----------------------------|------------------------------|---|--------------|--------------|--------------------|--------------|----------------|
| Rated motor capacity [kW] ① | | 0.1 | 0.2 | 0.4 | 0.75 | 1.5 | 2.2 |
| Output | Output capacity [kVA] ② | 0.3 | 0.6 | 1.2 | 2.0 | 3.2 | 4.4 |
| | Rated current [A] ③ | 0.8 (0.8) | 1.5 (1.4) | 3.0 (2.5) | 5.0 (4.1) | 8.0 (7.0) | 11.0 (10.0) |
| | Overload current rating ④ | 200% of rated motor capacity for 3s; 150% for 60s | | | | | |
| | Voltage ⑤ | 3-phase AC, 0V to power supply voltage | | | | | |
| Power supply | Power supply voltage | 1-phase, 200–240V AC, -15%/+10% | | | | | |
| | Voltage range | 170–264V AC at 50/60 Hz | | | | | |
| | Power supply frequency | 50/60Hz ± 5% | | | | | |
| | Rated input capacity [kVA] ⑥ | 0.5 | 0.9 | 1.5 | 2.5 | 4.0 | 5.2 |
| Protective structure | | IP20 | | | | | |
| Cooling system | | Self cooling | | | Forced air cooling | | |
| Weight [kg] | | 0.6 | 0.6 | 0.9 | 1.4 | 1.5 | 2.0 |

Tab. A-1: Specifications

- ① The applied motor capacity indicated is the maximum capacity applicable for use of the Mitsubishi 4-pole standard motor.
- ② The rated output capacity indicated assumes that the output voltage is 230V.
- ③ Setting 2kHz or more in Pr. 72 "PWM frequency selection" to perform low acoustic noise operation with the ambient temperature exceeding 40°C, the rated output current is the value in parentheses.
- ④ The % value of the overload current rating indicated is the ratio of the overload current to the inverter's rated output current. For repeated duty, allow time for the inverter and motor to return to or below the temperatures under 100% load. If the automatic restart after instantaneous power failure function (Pr. 57) or power failure stop function (Pr. 261) is set and power supply voltage is low while load becomes bigger, the bus voltage decreases to power failure detection level and load of 100% or more may not be available.
- ⑤ The maximum output voltage does not exceed the power supply voltage. The maximum output voltage can be changed within the setting range. However, the pulse voltage value of the inverter output side voltage remains unchanged at about $\sqrt{2}$ that of the power supply.
- ⑥ The power supply capacity varies with the value of the power supply side inverter impedance (including those of the input reactor and cables).

A.1.2 3-phase, 400V class

| Model FR-E740-□□□-EC | | 016 | 026 | 040 | 060 | 095 | 120 | 170 | 230 | 300 |
|-----------------------------|------------------------------|---|--------------|--------------|--------------------|--------------|-----|------|------|------|
| Rated motor capacity [kW] ① | | 0.4 | 0.75 | 1.5 | 2.2 | 3.7 | 5.5 | 7.5 | 11 | 15 |
| Output | Output capacity [kVA] ② | 1.2 | 2.0 | 3.0 | 4.6 | 7.2 | 9.1 | 13.0 | 17.5 | 23.0 |
| | Rated current [A] ③ | 1.6 (1.4) | 2.6 (2.2) | 4.0 (3.8) | 6.0 (5.4) | 9.5 (8.7) | 12 | 17 | 23 | 30 |
| | Overload current rating ④ | 200% of rated motor capacity for 3 s; 150% for 60 s | | | | | | | | |
| | Voltage ⑤ | 3-phase AC, 0V to power supply voltage | | | | | | | | |
| Power supply | Power supply voltage | 3-phase, 380–480V AC, –15%/+10% | | | | | | | | |
| | Voltage range | 325–528V AC at 50/60Hz | | | | | | | | |
| | Power supply frequency | 50/60 Hz ± 5% | | | | | | | | |
| | Rated input capacity [kVA] ⑥ | 1.5 | 2.5 | 4.5 | 5.5 | 9.5 | 12 | 17 | 20 | 28 |
| Protective structure | | IP20 | | | | | | | | |
| Cooling system | | Self cooling | | | Forced air cooling | | | | | |
| Weight [kg] | | 1.4 | 1.4 | 1.9 | 1.9 | 1.9 | 3.2 | 3.2 | 5.9 | 5.9 |

Tab. A-2: Specifications

- ① The applied motor capacity indicated is the maximum capacity applicable for use of the Mitsubishi 4-pole standard motor.
- ② The rated output capacity indicated assumes that the output voltage is 440V.
- ③ Setting 2kHz or more in Pr. 72 "PWM frequency selection" to perform low acoustic noise operation with the ambient temperature exceeding 40°C, the rated output current is the value in parentheses.
- ④ The % value of the overload current rating indicated is the ratio of the overload current to the inverter's rated output current. For repeated duty, allow time for the inverter and motor to return to or below the temperatures under 100% load.
- ⑤ The maximum output voltage does not exceed the power supply voltage. The maximum output voltage can be changed within the setting range. However, the pulse voltage value of the inverter output side voltage remains unchanged at about $\sqrt{2}$ that of the power supply.
- ⑥ The power supply capacity varies with the value of the power supply side inverter impedance (including those of the input reactor and cables).

A.2 Common specifications

| FR-E700 | | Specification | |
|-------------------------------|---|--|--|
| Control specification | Control system | V/f control, optimum excitation control, general-purpose magnetic flux vector control or advanced magnetic flux vector control can be selected | |
| | Modulation control | Sine evaluated PWM, Soft PWM | |
| | Output frequency range | 0.2–400Hz | |
| | Frequency setting resolution | Analog input | 0.06Hz/0–50Hz (terminal 2, 4: 0–10V/10bit) 0.12Hz/0–50Hz (terminal 2, 4: 0–5V/9bit) 0.06Hz/0–50Hz (terminal 4: 0/4–20mA/10bit) |
| | | Digital input | 0.01Hz |
| | Frequency accuracy | Analog input | ±0.5% of the maximum output frequency (temperature range 25°C ±10°C) |
| | | Digital input | ±0.01% of the set output frequency |
| | Voltage/frequency characteristics | Base frequency can be set from 0 to 400Hz Constant torque/variable torque pattern can be selected | |
| | Starting torque | 200% or more (at 0.5Hz) ... when advanced magnetic flux vector control is set (3.7K or less) | |
| | Torque boost | Manual torque boost | |
| | Acceleration/deceleration time | 0.01 to 360s; 0.1 to 3600s (can be set individually) | |
| | Acceleration/deceleration characteristics | Linear or S-form course, user selectable | |
| | Braking torque | Regenerative ① | FR-E720S-008 and 015 ... 150 %, FR-E720S-030 and 050, FR-E740-016 and 026 ... 100 %, FR-E720S-080, FR-E740-040 ... 50%, FR-E720S-0110, FR-E740-060 or more... 20% |
| DC injection brake | | Operation frequency (0 to 120Hz), operation time (0 to 10s) and operation voltage (0 to 30%) can be set individually. | |
| Stall prevention | Responses threshold 0–200%, user adjustable | | |
| Control signals for operation | Frequency setting values | Analog input | Terminal 2: 0–5V DC, 0–10V DC Terminal 4: 0–5V DC, 0–10V DC, 0/4–20mA |
| | | Digital input | Entered from operation panel and parameter unit |
| | Start signal | Forward and reverse rotation or start signal automatic self-holding input (3-wire input) can be selected. | |
| | Input signals | Any of 7 signals can be selected using parameters 178 to 184 "Input terminal function selection": multi-speed selection, remote setting, stop-on contact selection, second function selection, terminal 4 input selection, JOG operation selection, PID control valid terminal, brake opening completion signal, external thermal input, PU-external operation switchover, V/f switchover, output stop, start self-holding selection, forward rotation, reverse rotation command, inverter reset, PU-NET operation switchover, external-NET operation switchover, command source switchover, inverter operation enable signal, and PU operation external interlock | |
| | Operational functions | Maximum/minimum frequency setting, frequency jump operation, external thermal relay input selection, automatic restart after instantaneous power failure operation, forward/reverse rotation prevention, remote setting, brake sequence, second function, multi-speed operation, stop-on contact control, droop control, regeneration avoidance, slip compensation, operation mode selection, offline auto tuning function, PID control, computer link operation (RS-485) | |
| | Output signals | Open collector outputs | 2 points |
| | | Relay outputs | 1 point |
| | | Operating status | Selection can be made from inverter operation, up-to-frequency, overload alarm, output frequency detection, regenerative brake prealarm, electronic thermal relay function prealarm, inverter operation ready, output current detection, zero current detection, PID lower limit, PID upper limit, PID forward/reverse rotation output, brake opening request, fan alarm (FR-E720S-050 or more, FR-E740-040 or more), heatsink overheat pre-alarm, deceleration at an instantaneous power failure, PID control activated, during retry, life alarm, current average value monitor, remote output, alarm output, fault output, fault output 3, and maintenance timer alarm using Pr. 190 to Pr. 192 "Output terminal function selection". |
| | | Analog output | 0–10V DC: 1 point |
| | For meter | Selection can be made from output frequency, motor current (steady), output voltage, frequency setting, motor torque, converter output voltage, regenerative brake duty, electronic thermal relay function load factor, output current peak value, converter output voltage peak value, reference voltage output, motor load factor, PID set point, PID measured value, output power 0 to 10V DC using Pr. 158 "AM terminal function selection". | |

Tab. A-3: Common specifications (1)

| FR-E700 | | Specification | |
|-------------|--|--|---|
| Display | Operation panel or parameter unit (FR-PU07) | Operating status | You can select from among output frequency, motor current (steady), output voltage, frequency setting, cumulative energization time, actual operation time, motor torque, converter output voltage, regenerative brake duty, electronic thermal relay function load factor, output current peak value, converter output voltage peak value, motor load factor, PID set point, PID measured value, PID deviation, inverter I/O terminal monitor, I/O terminal option monitor, output power, cumulative power, motor thermal load factor, and inverter thermal load factor. |
| | | Fault definition | Fault definition is displayed when the protective function is activated, the output voltage/current/frequency/cumulative energizing time right before the protection function was activated and the past 8 alarm definitions are stored. |
| | Additional display by the parameter unit (FR-PU04/FRPU07) only | Operating status | Not used |
| | | Fault definition | Output voltage/current/frequency/cumulative energization time immediately before the fault occurs |
| | | Interactive guidance | Operation guide/trouble shooting with a help function |
| Protection | Protective functions | Overcurrent during acceleration, overcurrent during constant speed, overcurrent during deceleration, overvoltage during acceleration, overvoltage during constant speed, overvoltage during deceleration, inverter protection thermal operation, motor protection thermal operation, heatsink overheat, input phase failure ^② , output side earth (ground) fault overcurrent at start, output phase failure, external thermal relay operation ^③ , option fault, parameter error, internal board fault, PU disconnection, retry count excess ^③ , CPU fault, brake transistor alarm, inrush resistance overheat, communication error, analog input error, USB communication error, brake sequence error 4 to 7 ^③ | |
| | Warning functions | Fan alarm (FR-E720S-050 or more, FR-E740-040 or more), overcurrent stall prevention, overvoltage stall prevention, PU stop, parameter write error, regenerative brake prealarm ^③ , electronic thermal relay function prealarm, maintenance output ^③ , undervoltage | |
| Environment | Ambient temperature | -10°C to +50°C (non-freezing) ^④ | |
| | Storage temperature ^⑤ | -20°C to +65°C | |
| | Ambient humidity | Max. 90% (non-condensing) | |
| | Ambience conditions | For indoor use only, avoid environments containing corrosive gases, install in a dust-free location. | |
| | Altitude | Max. 1000m above sea level | |
| | Vibration resistance | Max. 5.9m/s ² (JIS 60068-2-6) or less at 10 to 55Hz (directions of X, Y and Z axes) | |

Tab. A-3: Common specifications (2)

- ① The braking torque indicated is a short-duration average torque (which varies with motor loss) when the motor alone is decelerated from 60Hz in the shortest time and is not a continuous regenerative torque. When the motor is decelerated from the frequency higher than the base frequency, the average deceleration torque will reduce. Since the inverter does not contain a brake resistor, use the optional brake resistor when regenerative energy is large. A brake unit (FR-BU2) may also be used.
- ② This protective function is available with the three-phase power input specification model only.
- ③ This protective function does not function in the initial status.
- ④ When using the inverters at the ambient temperature of 40°C or less, the inverters can be installed closely attached (0cm clearance).
- ⑤ The product may only be exposed to the full extremes of this temperature range for short periods (e.g. during transportation).

A.3 Outline dimension drawings

A.3.1 FR-E720S-008 to 030

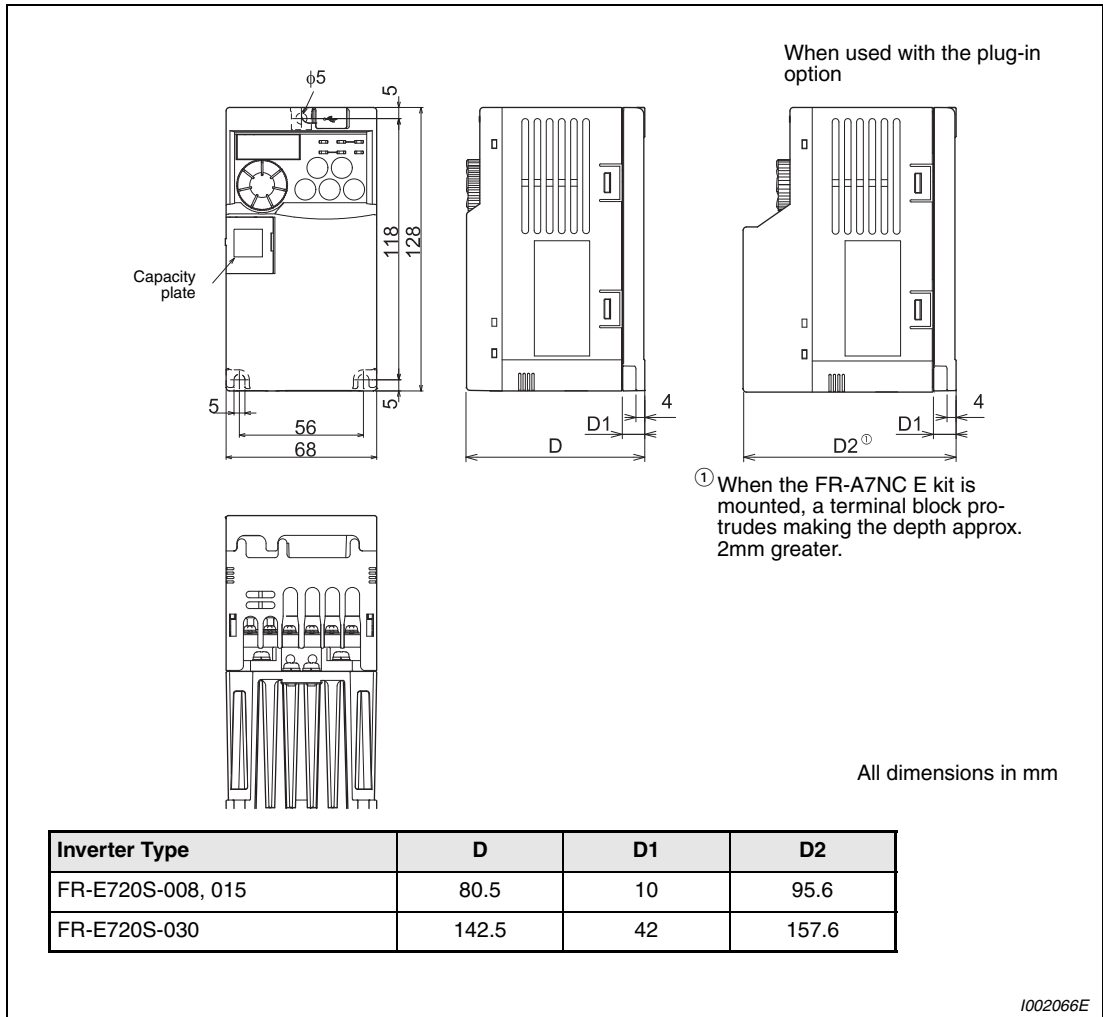

Fig. A-1: Dimensions FR-E720S-008 to 030

A.3.2 FR-E720S-050 and 080

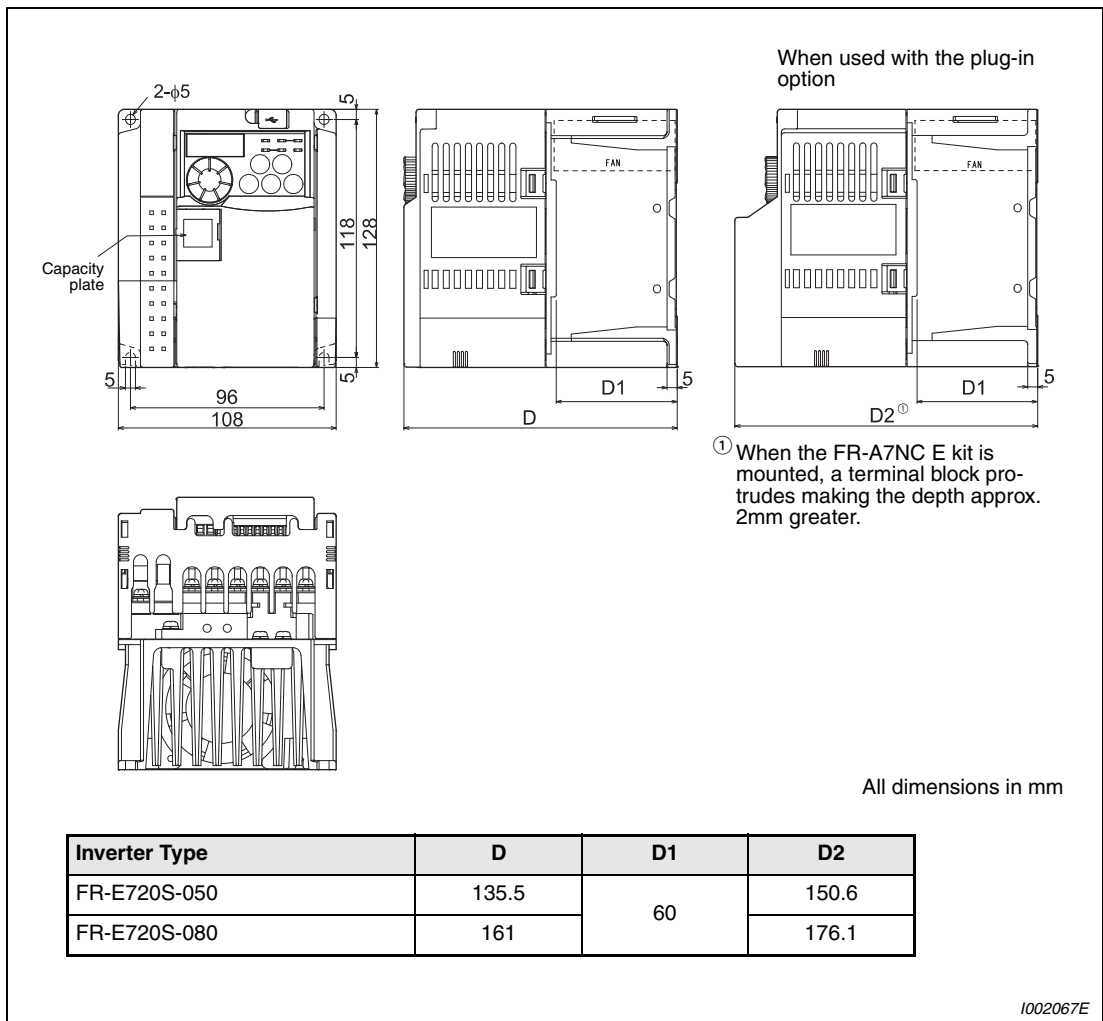

Fig. A-2: Dimensions FR-E720S-050 and 080

A.3.3 FR-E720S-110 and FR-E740-016 to 095

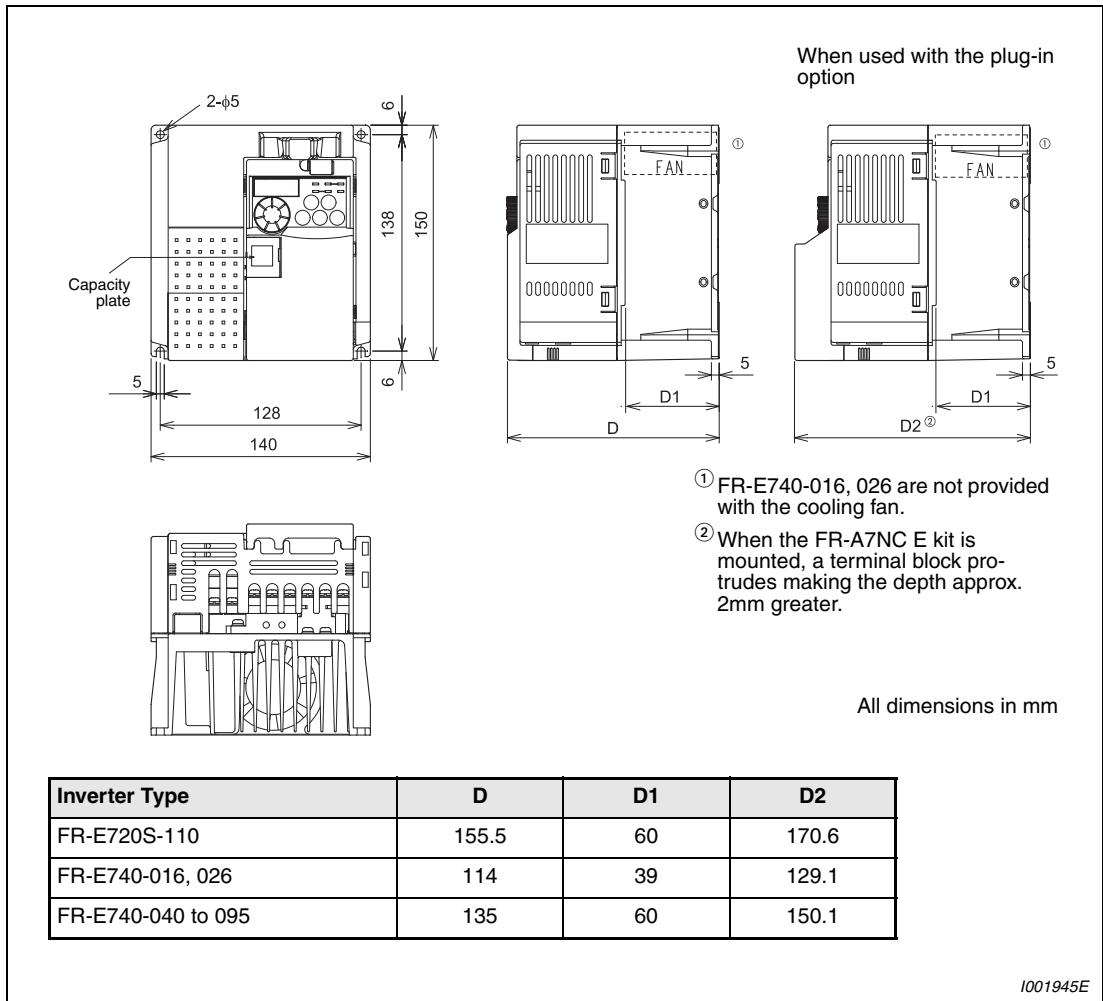

Fig. A-3: Dimensions FR-E720S-110 and FR-E740-016 to 095

A.3.4 FR-E740-120 and 170

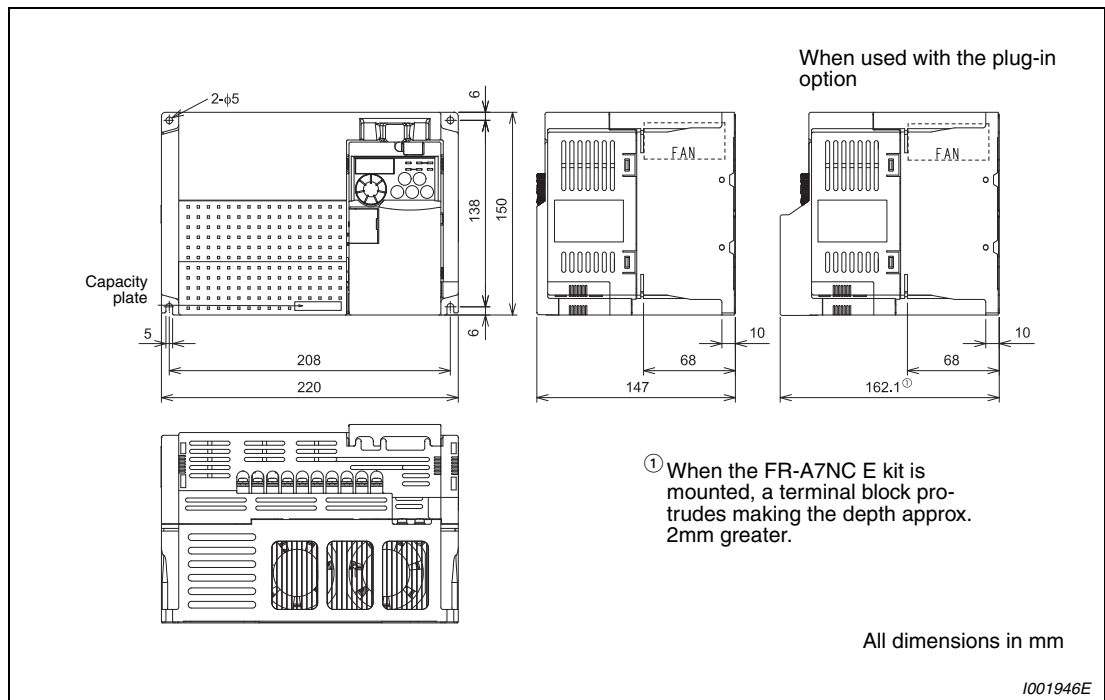

Fig. A-4: Dimensions FR-E740-120 and 170

A.3.5 FR-E740-230 and 300

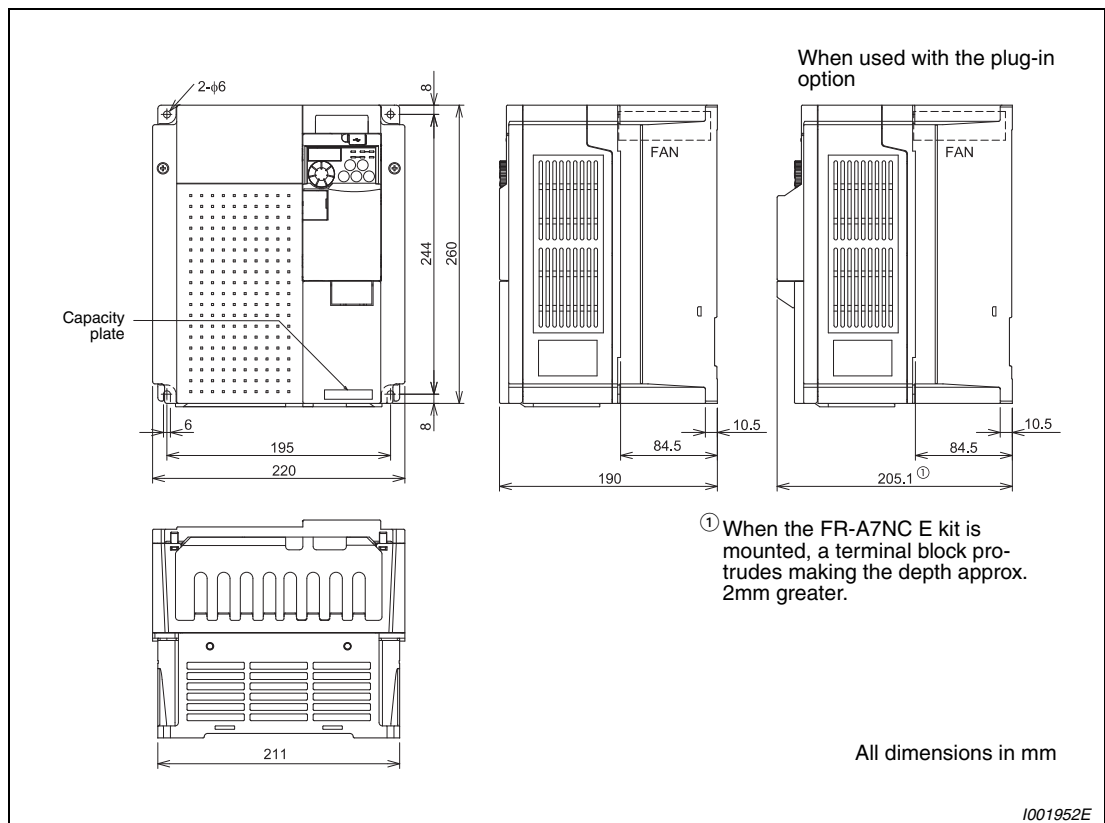

Fig. A-5: Dimensions FR-E740-230 and 300

A.3.6 Parameter unit FR-PU07

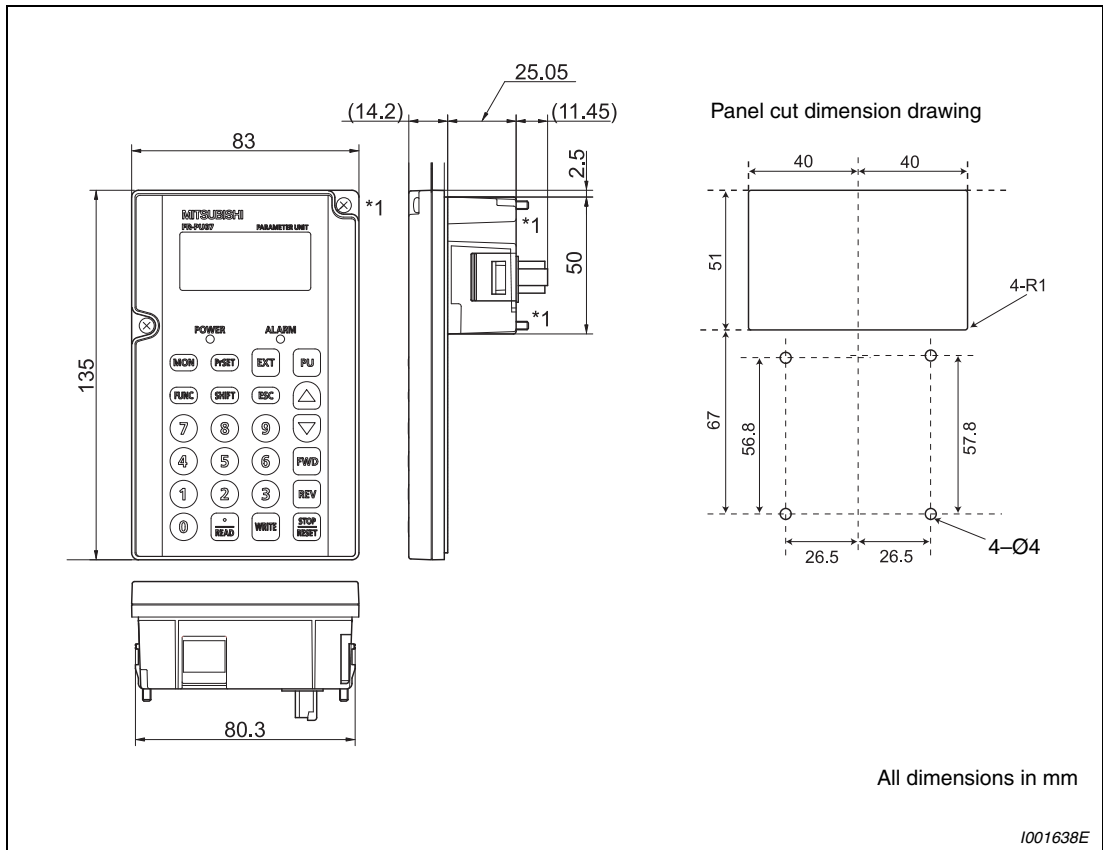

Fig. A-6: Parameter unit FR-PU07

NOTES

When installing the FR-PU07 on the enclosure, etc., remove screws or fix the screws to the FR-PU07 with M3 nuts.

The effective depth of the M3 installation screw hole is 5.0mm.

A.3.7 Parameter unit FR-PA07

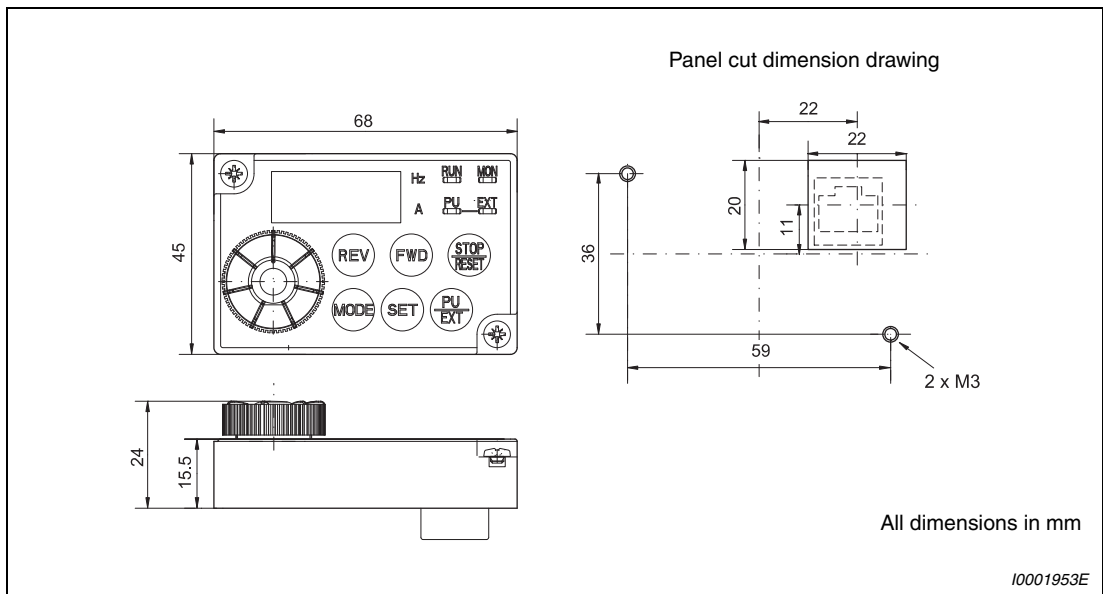

Fig. A-7: Parameter unit FR-PA07

A.4 Parameter list with instruction codes

In the initial setting status, simple mode parameters and extended parameters can be displayed. Set Pr. 160 "User group read selection" as required. So check the setting of Pr. 160 if parameters are not shown or change the setting of Pr. 160 to lock parameters.

| Parameter | Name | Initial Value | Setting Range | Remarks |
|-----------|---------------------------|---------------|---------------|--|
| 160 | User group read selection | 0 | 9999 | Only the simple mode parameters can be displayed. |
| | | | 0 | Simple mode and extended mode parameters can be displayed. |
| | | | 1 | Only parameters registered in the user group can be displayed. |

Tab. A-4: Settings of parameter 160

NOTES

The parameters marked © are the simple mode parameters.

The parameters marked with in the table allow its setting to be changed during operation even if "0" (initial value) is set in Pr. 77 "Parameter write selection".

Parameters for the option are displayed only when the option unit is installed.

The instruction codes (hexadecimal) for "read" and "write" on the right of the parameter number are those used to set the parameter via communication. "Extended" indicates the setting of the extended link parameter. (Refer to section 6.19 for communication.)

The symbols in the table have the following meanings:

✓: Setting the parameter is possible for this operation mode.

—: Setting the parameter is impossible for this operation mode.

| Function | Parameter | Instruction Code | | | Name | Control Mode-based Correspondence Table | | | Refer to Page | Customer Setting | |
|-----------------|-----------|------------------|-------|----------|------------------------------|---|--|---------------------------------------|---------------|------------------|--|
| | | Read | Write | Extended | | V/f control | General-purpose magnetic flux vector control | Advanced magnetic flux vector control | | | |
| Basic functions | © 0 | 00 | 80 | 0 | Torque boost | ✓ | — | — | 6-33 | | |
| | © 1 | 01 | 81 | 0 | Maximum frequency | ✓ | ✓ | ✓ | 6-50 | | |
| | © 2 | 02 | 82 | 0 | Minimum frequency | ✓ | ✓ | ✓ | | | |
| | © 3 | 03 | 83 | 0 | Base frequency | ✓ | — | — | 6-54 | | |
| | © 4 | 04 | 84 | 0 | Multi-speed setting | RH | ✓ | ✓ | 6-58 | | |
| | © 5 | 05 | 85 | 0 | | RM | ✓ | ✓ | | ✓ | |
| | © 6 | 06 | 86 | 0 | | RL | ✓ | ✓ | | ✓ | |
| | © 7 | 07 | 87 | 0 | Acceleration time | ✓ | ✓ | ✓ | 6-69 | | |
| | © 8 | 08 | 88 | 0 | Deceleration time | ✓ | ✓ | ✓ | | | |
| | © 9 | 09 | 89 | 0 | Electronic thermal O/L relay | ✓ | ✓ | ✓ | 6-80 | | |

Tab. A-5: Parameter list with instruction codes (1)

| Function | Parameter | Instruction Code | | | Name | Control Mode-based Correspondence Table | | | Refer to Page | Customer Setting | |
|--------------------------------|-----------|------------------|-------|----------|--|---|--|---------------------------------------|---------------|------------------|--|
| | | Read | Write | Extended | | V/f control | General-purpose magnetic flux vector control | Advanced magnetic flux vector control | | | |
| DC injection brake | 10 | 0A | 8A | 0 | DC injection brake operation | Frequency | ✓ | ✓ | ✓ | 6-98 | |
| | 11 | 0B | 8B | 0 | | Time | ✓ | ✓ | ✓ | | |
| | 12 | 0C | 8C | 0 | | Voltage | ✓ | ✓ | ✓ | | |
| — | 13 | 0D | 8D | 0 | Starting frequency | ✓ | ✓ | ✓ | 6-73 | | |
| — | 14 | 0E | 8E | 0 | Load pattern selection | ✓ | — | — | 6-56 | | |
| Jog operation | 15 | 0F | 8F | 0 | Jog frequency | ✓ | ✓ | ✓ | 6-61 | | |
| | 16 | 10 | 90 | 0 | Jog acceleration/deceleration time | ✓ | ✓ | ✓ | | | |
| — | 17 | 11 | 91 | 0 | MRS input selection | ✓ | ✓ | ✓ | 6-117 | | |
| — | 18 | 12 | 92 | 0 | High speed maximum frequency | ✓ | ✓ | ✓ | 6-50 | | |
| — | 19 | 13 | 93 | 0 | Base frequency voltage | ✓ | — | — | 6-54 | | |
| Acceleration/deceleration time | 20 | 14 | 94 | 0 | Acceleration/deceleration reference frequency | ✓ | ✓ | ✓ | 6-69 | | |
| | 21 | 15 | 95 | 0 | Acceleration/deceleration time increments | ✓ | ✓ | ✓ | | | |
| Stall prevention | 22 | 16 | 96 | 0 | Stall prevention operation level | ✓ | ✓ | ✓ | 6-42 | | |
| | 23 | 17 | 97 | 0 | Stall prevention operation level compensation factor at double speed | ✓ | ✓ | ✓ | | | |
| Multi-speed setting | 24 | 18 | 98 | 0 | Multi-speed setting (speed 4) | ✓ | ✓ | ✓ | 6-58 | | |
| | 25 | 19 | 99 | 0 | Multi-speed setting (speed 5) | ✓ | ✓ | ✓ | | | |
| | 26 | 1A | 9A | 0 | Multi-speed setting (speed 6) | ✓ | ✓ | ✓ | | | |
| | 27 | 1B | 9B | 0 | Multi-speed setting (speed 7) | ✓ | ✓ | ✓ | | | |
| — | 29 | 1D | 9D | 0 | Acceleration/deceleration pattern selection | ✓ | ✓ | ✓ | 6-75 | | |
| — | 30 | 1E | 9E | 0 | Regenerative function selection | ✓ | ✓ | ✓ | 6-101 | | |
| Frequency jump | 31 | 1F | 9F | 0 | Frequency jump 1A | ✓ | ✓ | ✓ | 6-52 | | |
| | 32 | 20 | A0 | 0 | Frequency jump 1B | ✓ | ✓ | ✓ | | | |
| | 33 | 21 | A1 | 0 | Frequency jump 2A | ✓ | ✓ | ✓ | | | |
| | 34 | 22 | A2 | 0 | Frequency jump 2B | ✓ | ✓ | ✓ | | | |
| | 35 | 23 | A3 | 0 | Frequency jump 3A | ✓ | ✓ | ✓ | | | |
| | 36 | 24 | A4 | 0 | Frequency jump 3B | ✓ | ✓ | ✓ | | | |
| — | 37 | 25 | A5 | 0 | Speed display | ✓ | ✓ | ✓ | 6-136 | | |
| — | 40 | 28 | A8 | 0 | RUN key rotation direction selection | ✓ | ✓ | ✓ | 6-306 | | |
| Frequency detection (SU, FU) | 41 | 29 | A9 | 0 | Up-to-frequency sensitivity | ✓ | ✓ | ✓ | 6-129 | | |
| | 42 | 2A | AA | 0 | Output frequency detection | ✓ | ✓ | ✓ | | | |
| | 43 | 2B | AB | 0 | Output frequency detection for reverse rotation | ✓ | ✓ | ✓ | | | |

Tab. A-5: Parameter list with instruction codes (2)

| Function | Parameter | Instruction Code | | | Name | Control Mode-based Correspondence Table | | | Refer to Page | Customer Setting | |
|-------------------------------------|-----------|------------------|-----------------|----------|---|---|--|---------------------------------------|---------------|------------------|--|
| | | Read | Write | Extended | | V/f control | General-purpose magnetic flux vector control | Advanced magnetic flux vector control | | | |
| Second functions | 44 | 2C | AC | 0 | Second acceleration/deceleration time | ✓ | ✓ | ✓ | 6-69 | | |
| | 45 | 2D | AD | 0 | Second deceleration time | ✓ | ✓ | ✓ | | | |
| | 46 | 2E | AE | 0 | Second torque boost | ✓ | — | — | 6-33 | | |
| | 47 | 2F | AF | 0 | Second V/F (base frequency) | ✓ | — | — | 6-54 | | |
| | 48 | 30 | B0 | 0 | Second stall prevention operation current | ✓ | ✓ | ✓ | 6-42 | | |
| | 51 | 33 | B3 | 0 | Second electronic thermal O/L relay | ✓ | ✓ | ✓ | 6-80 | | |
| Monitor functions | 52 | 34 | B4 | 0 | DU/PU main display data selection | ✓ | ✓ | ✓ | 6-138 | | |
| | 55 | 37 | B7 | 0 | Frequency monitoring reference | ✓ | ✓ | ✓ | 6-146 | | |
| | 56 | 38 | B8 | 0 | Current monitoring reference | ✓ | ✓ | ✓ | | | |
| Automatic restart functions | 57 | 39 | B9 | 0 | Restart coasting time | ✓ | ✓ | ✓ | 6-151 | | |
| | 58 | 3A | BA | 0 | Restart cushion time | ✓ | ✓ | ✓ | | | |
| — | 59 | 3B | BB | 0 | Remote function selection | ✓ | ✓ | ✓ | 6-65 | | |
| — | 60 | 3C | BC | 0 | Energy saving control selection | ✓ | — | — | 6-171 | | |
| Automatic acceleration/deceleration | 61 | 3D | BD | 0 | Automatic acceleration/deceleration | Reference current | ✓ | ✓ | 6-77 | | |
| | 62 | 3E | BE | 0 | | Reference value at acceleration | ✓ | ✓ | | ✓ | |
| | 63 | 3F | BF | 0 | | Reference value at deceleration | ✓ | ✓ | | ✓ | |
| Retry function at alarm occurrence | 65 | 41 | C1 | 0 | Retry selection | ✓ | ✓ | ✓ | 6-166 | | |
| — | 66 | 42 | C2 | 0 | Stall prevention operation reduction starting frequency | ✓ | ✓ | ✓ | 6-42 | | |
| Retry function at alarm occurrence | 67 | 43 | C3 | 0 | Number of retries at alarm occurrence | ✓ | ✓ | ✓ | 6-166 | | |
| | 68 | 44 | C4 | 0 | Retry waiting time | ✓ | ✓ | ✓ | | | |
| | 69 | 45 | C5 | 0 | Retry count display erase | ✓ | ✓ | ✓ | | | |
| — | 70 | 46 | C6 | 0 | Special regenerative brake duty | ✓ | ✓ | ✓ | 6-101 | | |
| — | 71 | 47 | C7 | 0 | Applied motor | ✓ | ✓ | ✓ | 6-85 | | |
| — | 72 | 48 | C8 | 0 | PWM frequency selection | ✓ | ✓ | ✓ | 6-172 | | |
| — | 73 | 49 | C9 | 0 | Analog input selection | ✓ | ✓ | ✓ | 6-174 | | |
| — | 74 | 4A | CA | 0 | Input filter time constant | ✓ | ✓ | ✓ | 6-179 | | |
| — | 75 | 4B | CB | 0 | Reset selection/disconnected PU detection/PU stop selection | ✓ | ✓ | ✓ | 6-187 | | |
| — | 77 | 4D | CD ^① | 0 | Parameter write selection | ✓ | ✓ | ✓ | 6-192 | | |
| — | 78 | 4E | CE | 0 | Reverse rotation prevention selection | ✓ | ✓ | ✓ | 6-194 | | |
| — | ⊗ 79 | 4F | CF ^① | 0 | Operation mode selection | ✓ | ✓ | ✓ | 6-198 | | |

Tab. A-5: Parameter list with instruction codes (3)

① Can be written by only communication from the PU connector.

| Function | Parameter | Instruction Code | | | Name | Control Mode-based Correspondence Table | | | Refer to Page | Customer Setting |
|----------------------------|-----------|------------------|-------|----------------------------|--|---|--|---------------------------------------|---------------|------------------|
| | | Read | Write | Extended | | V/f control | General-purpose magnetic flux vector control | Advanced magnetic flux vector control | | |
| Vector control | 80 | 50 | D0 | 0 | Motor capacity | — | ✓ | ✓ | 6-36 | |
| | 81 | 51 | D1 | 0 | Number of motor poles | — | ✓ | ✓ | | |
| | 82 | 52 | D2 | 0 | Motor excitation current | — | ✓ | ✓ | | 6-88 |
| | 83 | 53 | D3 | 0 | Motor rated voltage | — | ✓ | ✓ | | |
| | 84 | 54 | D4 | 0 | Rated motor frequency | — | ✓ | ✓ | 6-36 | |
| | 89 | 59 | D9 | 0 | Speed control gain (advanced magnetic flux vector) | — | ✓ | — | | |
| | 90 | 5A | DA | 0 | Motor constants | R1 | — | ✓ | | ✓ |
| | 91 | 5B | DB | 0 | | R2 | — | ✓ | | ✓ |
| | 92 | 5C | DC | 0 | | L1 | — | ✓ | | ✓ |
| | 93 | 5D | DD | 0 | | L2 | — | ✓ | | ✓ |
| | 94 | 5E | DE | 0 | | X | — | ✓ | | ✓ |
| 96 | 60 | E0 | 0 | Auto tuning setting/status | ✓ | ✓ | ✓ | | | |
| PU connector communication | 117 | 11 | 91 | 1 | PU communication station number | ✓ | ✓ | ✓ | 6-226 | |
| | 118 | 12 | 92 | 1 | PU communication speed | ✓ | ✓ | ✓ | | |
| | 119 | 13 | 93 | 1 | PU communication stop bit length | ✓ | ✓ | ✓ | | |
| | 120 | 14 | 94 | 1 | PU communication parity check | ✓ | ✓ | ✓ | | |
| | 121 | 15 | 95 | 1 | Number of PU communication retries | ✓ | ✓ | ✓ | | |
| | 122 | 16 | 96 | 1 | PU communication check time interval | ✓ | ✓ | ✓ | | |
| | 123 | 17 | 97 | 1 | PU communication waiting time setting | ✓ | ✓ | ✓ | | |
| | 124 | 18 | 98 | 1 | PU communication CR/LF selection | ✓ | ✓ | ✓ | | |
| — | Ⓒ 125 | 19 | 99 | 1 | Terminal 2 frequency setting gain frequency | ✓ | ✓ | ✓ | 6-180 | |
| — | Ⓒ 126 | 1A | 9A | 1 | Terminal 4 frequency setting gain frequency | ✓ | ✓ | ✓ | | |
| PID control | 127 | 1B | 9B | 1 | PID control automatic switchover frequency | ✓ | ✓ | ✓ | 6-270 | |
| | 128 | 1C | 9C | 1 | PID action selection | ✓ | ✓ | ✓ | | |
| | 129 | 1D | 9D | 1 | PID proportional band | ✓ | ✓ | ✓ | | |
| | 130 | 1E | 9E | 1 | PID integral time | ✓ | ✓ | ✓ | | |
| | 131 | 1F | 9F | 1 | PID upper limit | ✓ | ✓ | ✓ | | |
| | 132 | 20 | A0 | 1 | PID lower limit | ✓ | ✓ | ✓ | | |
| | 133 | 21 | A1 | 1 | PID action set point | ✓ | ✓ | ✓ | | |
| | 134 | 22 | A2 | 1 | PID differential time | ✓ | ✓ | ✓ | | |

Tab. A-5: Parameter list with instruction codes (4)

| Function | Parameter | Instruction Code | | | Name | Control Mode-based Correspondence Table | | | Refer to Page | Customer Setting |
|-------------------------------------|-----------|--|-------|----------|---|---|--|---------------------------------------|---------------|------------------|
| | | Read | Write | Extended | | V/f control | General-purpose magnetic flux vector control | Advanced magnetic flux vector control | | |
| PU | 145 | 2D | AD | 1 | PU display language selection | ✓ | ✓ | ✓ | 6-306 | |
| — | 146 | Parameter for manufacturer setting. Do not make setting. | | | | | | | | |
| — | 147 | 2F | AF | 1 | Acceleration/deceleration switching frequency | ✓ | ✓ | ✓ | 6-69 | |
| Current detection | 150 | 32 | B2 | 1 | Output current detection level | ✓ | ✓ | ✓ | 6-131 | |
| | 151 | 33 | B3 | 1 | Output current detection signal delay time | ✓ | ✓ | ✓ | | |
| | 152 | 34 | B4 | 1 | Zero current detection level | ✓ | ✓ | ✓ | | |
| | 153 | 35 | B5 | 1 | Zero current detection time | ✓ | ✓ | ✓ | | |
| — | 156 | 38 | B8 | 1 | Stall prevention operation selection | ✓ | ✓ | ✓ | 6-42 | |
| — | 157 | 39 | B9 | 1 | OL signal output timer | ✓ | ✓ | ✓ | | |
| Display selection | 158 | 3A | BA | 1 | AM terminal function selection | ✓ | ✓ | ✓ | 6-138 | |
| — | Ⓢ 160 | 00 | 80 | 2 | User group read selection | ✓ | ✓ | ✓ | 6-195 | |
| — | 161 | 01 | 81 | 2 | Frequency setting/key lock operation selection | ✓ | ✓ | ✓ | 6-307 | |
| Automatic restart functions | 162 | 02 | 82 | 2 | Automatic restart after instantaneous power failure selection | ✓ | ✓ | ✓ | 6-151 | |
| | 165 | 05 | 85 | 2 | Stall prevention operation level for restart | ✓ | ✓ | ✓ | | |
| — | 168 | Parameter for manufacturer setting. Do not make setting. | | | | | | | | |
| — | 169 | Parameter for manufacturer setting. Do not make setting. | | | | | | | | |
| Cumulative monitor clear | 170 | 0A | 8A | 2 | Watt-hour meter clear | ✓ | ✓ | ✓ | 6-138 | |
| | 171 | 0B | 8B | 2 | Operation hour meter clear | ✓ | ✓ | ✓ | | |
| User group | 172 | 0C | 8C | 2 | User group registered display/batch clear | ✓ | ✓ | ✓ | 6-195 | |
| | 173 | 0D | 8D | 2 | User group registration | ✓ | ✓ | ✓ | | |
| | 174 | 0E | 8E | 2 | User group clear | ✓ | ✓ | ✓ | | |
| Input terminal function assignment | 178 | 12 | 92 | 2 | Function selection | STF terminal | ✓ | ✓ | 6-114 | |
| | 179 | 13 | 93 | 2 | | STR terminal | ✓ | ✓ | | |
| | 180 | 14 | 94 | 2 | | RL terminal | ✓ | ✓ | | |
| | 181 | 15 | 95 | 2 | | RM terminal | ✓ | ✓ | | |
| | 182 | 16 | 96 | 2 | | RH terminal | ✓ | ✓ | | |
| | 183 | 17 | 97 | 2 | | MRS terminal | ✓ | ✓ | | |
| Output terminal function assignment | 184 | 18 | 98 | 2 | RES terminal | ✓ | ✓ | ✓ | 6-124 | |
| | 190 | 1E | 9E | 2 | Function selection | RUN terminal | ✓ | ✓ | | |
| | 191 | 1F | 9F | 2 | FU terminal | ✓ | ✓ | ✓ | | |
| | 192 | 20 | A0 | 2 | A, B and C terminal | ✓ | ✓ | ✓ | | |

Tab. A-5: Parameter list with instruction codes (5)

| Function | Parameter | Instruction Code | | | Name | Control Mode-based Correspondence Table | | | Refer to Page | Customer Setting |
|-------------------------|-----------|--|-------|----------|---|---|--|---------------------------------------|---------------|------------------|
| | | Read | Write | Extended | | V/f control | General-purpose magnetic flux vector control | Advanced magnetic flux vector control | | |
| Multi-speed setting | 232 | 28 | A8 | 2 | Multi-speed setting (speeds 8) | ✓ | ✓ | ✓ | 6-58 | |
| | 233 | 29 | A9 | 2 | Multi-speed setting (speeds 9) | ✓ | ✓ | ✓ | | |
| | 234 | 2A | AA | 2 | Multi-speed setting (speeds 10) | ✓ | ✓ | ✓ | | |
| | 235 | 2B | AB | 2 | Multi-speed setting (speeds 11) | ✓ | ✓ | ✓ | | |
| | 236 | 2C | AC | 2 | Multi-speed setting (speeds 12) | ✓ | ✓ | ✓ | | |
| | 237 | 2D | AD | 2 | Multi-speed setting (speeds 13) | ✓ | ✓ | ✓ | | |
| | 238 | 2E | AE | 2 | Multi-speed setting (speeds 14) | ✓ | ✓ | ✓ | | |
| — | 239 | 2F | AF | 2 | Multi-speed setting (speeds 15) | ✓ | ✓ | ✓ | | |
| — | 240 | 30 | B0 | 2 | Soft-PWM operation selection | ✓ | ✓ | ✓ | 6-172 | |
| — | 241 | 31 | B1 | 2 | Analog input display unit switch over | ✓ | ✓ | ✓ | 6-180 | |
| — | 244 | 34 | B4 | 2 | Cooling fan operation selection | ✓ | ✓ | ✓ | 6-295 | |
| Slip compensation | 245 | 35 | B5 | 2 | Rated slip | ✓ | — | ✓ | 6-41 | |
| | 246 | 36 | B6 | 2 | Slip compensation time constant | ✓ | — | ✓ | | |
| | 247 | 37 | B7 | 2 | Constant-output region slip compensation selection | ✓ | — | ✓ | | |
| — | 249 | 39 | B9 | 2 | Earth (ground) fault detection at start | ✓ | ✓ | ✓ | 6-170 | |
| — | 250 | 3A | BA | 2 | Stop selection | ✓ | ✓ | ✓ | 6-103 | |
| — | 251 | 3B | BB | 2 | Output phase failure protection selection | ✓ | ✓ | ✓ | 6-169 | |
| Life check | 255 | 3F | BF | 2 | Life alarm status display | ✓ | ✓ | ✓ | 6-296 | |
| | 256 | 40 | C0 | 2 | Inrush current suppression circuit life display | ✓ | ✓ | ✓ | | |
| | 257 | 41 | C1 | 2 | Control circuit capacitor life display | ✓ | ✓ | ✓ | | |
| | 258 | 42 | C2 | 2 | Main circuit capacitor life display | ✓ | ✓ | ✓ | | |
| | 259 | 43 | C3 | 2 | Main circuit capacitor life measuring | ✓ | ✓ | ✓ | | |
| Power failure stop | 261 | 45 | C5 | 2 | Power failure stop selection | ✓ | ✓ | ✓ | 6-162 | |
| — | 267 | 4B | CB | 2 | Terminal 4 input selection | ✓ | ✓ | ✓ | 6-174 | |
| — | 268 | 4C | CC | 2 | Monitor decimal digits selection | ✓ | ✓ | ✓ | 6-138 | |
| — | 269 | Parameter for manufacturer setting. Do not make setting. | | | | | | | | |
| Stop-on contact control | 270 | 4E | CE | 2 | Stop-on contact control selection | — | ✓ | ✓ | 6-105 | |
| | 275 | 53 | D3 | 2 | Stop-on contact excitation current low-speed multiplying factor | — | ✓ | ✓ | | |
| | 276 | 54 | D4 | 2 | PWM carrier frequency at stop-on contact | — | ✓ | ✓ | | |
| — | 277 | 55 | D5 | 2 | Stall prevention operation current switchover | ✓ | ✓ | ✓ | 6-42 | |

Tab. A-5: Parameter list with instruction codes (6)

| Function | Parameter | Instruction Code | | | Name | Control Mode-based Correspondence Table | | | Refer to Page | Customer Setting |
|-------------------------------|-----------|------------------|-------|----------|--|---|--|---------------------------------------|---------------|------------------|
| | | Read | Write | Extended | | V/f control | General-purpose magnetic flux vector control | Advanced magnetic flux vector control | | |
| Brake sequence function | 278 | 56 | D6 | 2 | Brake opening frequency | — | ✓ | ✓ | 6-109 | |
| | 279 | 57 | D7 | 2 | Brake opening current | — | ✓ | ✓ | | |
| | 280 | 58 | D8 | 2 | Brake opening current detection time | — | ✓ | ✓ | | |
| | 281 | 59 | D9 | 2 | Brake operation time at start | — | ✓ | ✓ | | |
| | 282 | 5A | DA | 2 | Brake operation frequency | — | ✓ | ✓ | | |
| | 283 | 5B | DB | 2 | Brake operation time at stop | — | ✓ | ✓ | | |
| Droop control | 286 | 5E | DE | 2 | Droop gain | — | ✓ | — | 6-291 | |
| | 287 | 5F | DE | 2 | Droop filter time constant | — | ✓ | — | | |
| — | 292 | 64 | E4 | 2 | Automatic acceleration/deceleration | ✓ | ✓ | ✓ | 6-77 | |
| — | 293 | 65 | E5 | 2 | Acceleration/deceleration separate selection | ✓ | ✓ | ✓ | | |
| | 295 | 67 | E7 | 2 | Magnitude of frequency change setting | ✓ | ✓ | ✓ | 6-308 | |
| | 298 | 6A | EA | 2 | Frequency search gain | ✓ | ✓ | ✓ | 6-151 | |
| — | 299 | 6B | EB | 2 | Rotation direction detection selection at restarting | ✓ | ✓ | ✓ | | |
| Digital input (FR-A7AX E kit) | 300 | 00 | 80 | 3 | BCD input | Bias | ✓ | ✓ | — | |
| | 301 | 01 | 81 | 3 | | Gain | ✓ | ✓ | | ✓ |
| | 302 | 02 | 82 | 3 | BIN input | Bias | ✓ | ✓ | | ✓ |
| | 303 | 03 | 83 | 3 | | Gain | ✓ | ✓ | | ✓ |
| | 304 | 04 | 84 | 3 | Digital input and analog input compensation enable/disable selection | ✓ | ✓ | ✓ | | |
| | 305 | 05 | 85 | 3 | Read timing operation selection | ✓ | ✓ | ✓ | | |
| Analog output (FR-A7AY E kit) | 306 | 06 | 86 | 3 | Analog output signal selection | ✓ | ✓ | ✓ | — | |
| | 307 | 07 | 87 | 3 | Setting for zero analog output | ✓ | ✓ | ✓ | | |
| | 308 | 08 | 88 | 3 | Setting for maximum analog output | ✓ | ✓ | ✓ | | |
| | 309 | 09 | 89 | 3 | Analog output signal voltage/current switch over | ✓ | ✓ | ✓ | | |
| | 310 | 0A | 8A | 3 | Analog meter voltage output selection | ✓ | ✓ | ✓ | | |
| | 311 | 0B | 8B | 3 | Setting for zero analog meter voltage output | ✓ | ✓ | ✓ | | |
| | 312 | 0C | 8C | 3 | Setting for maximum analog meter voltage output | ✓ | ✓ | ✓ | | |

Tab. A-5: Parameter list with instruction codes (7)

| Function | Parameter | Instruction Code | | | Name | Control Mode-based Correspondence Table | | | Refer to Page | Customer Setting | |
|--|-----------|------------------|-------|----------|---|---|--|---------------------------------------|---------------|------------------|--|
| | | Read | Write | Extended | | V/f control | General-purpose magnetic flux vector control | Advanced magnetic flux vector control | | | |
| Analog output (FR-A7AY E kit) | 313 | 0D | 8D | 3 | Function selection | Y0 terminal | ✓ | ✓ | ✓ | — | |
| | 314 | 0E | 8E | 3 | | Y1 terminal | ✓ | ✓ | ✓ | | |
| | 315 | 0F | 8F | 3 | | Y2 terminal | ✓ | ✓ | ✓ | | |
| | 316 | 10 | 90 | 3 | | Y3 terminal | ✓ | ✓ | ✓ | | |
| | 317 | 11 | 91 | 3 | | Y4 terminal | ✓ | ✓ | ✓ | | |
| | 318 | 12 | 92 | 3 | | Y5 terminal | ✓ | ✓ | ✓ | | |
| | 319 | 13 | 93 | 3 | | Y6 terminal | ✓ | ✓ | ✓ | | |
| Relay output (FR-A7AR E kit) | 320 | 14 | 94 | 3 | Function selection | RA1 terminal | ✓ | ✓ | ✓ | — | |
| | 321 | 15 | 95 | 3 | | RA2 terminal | ✓ | ✓ | ✓ | | |
| | 322 | 16 | 96 | 3 | | RA3 terminal | ✓ | ✓ | ✓ | | |
| Analog output (FR-A7AY E kit) | 323 | 17 | 97 | 3 | AM0 0V adjustment | ✓ | ✓ | ✓ | — | | |
| | 324 | 18 | 98 | 3 | AM1 0mA adjustment | ✓ | ✓ | ✓ | | | |
| Digital input (FR-A7AX E kit) | 329 | 1D | 9D | 3 | Digital input unit selection | ✓ | ✓ | ✓ | — | | |
| RS-485 communication | 338 | 26 | A6 | 3 | Communication operation command source | * | ✓ | ✓ | 6-212 | | |
| | 339 | 27 | A7 | 3 | Communication speed command source | ✓ | ✓ | ✓ | | | |
| | 340 | 28 | A8 | 3 | Communication start-up mode selection | ✓ | ✓ | ✓ | 6-210 | | |
| | 342 | 2A | AA | 3 | Communication E ² PROM write selection | ✓ | ✓ | ✓ | 6-226 | | |
| | 343 | 2B | AB | 3 | Communication error count | ✓ | ✓ | ✓ | | | |
| DeviceNet communication (FR-A7ND E kit FR-A7NCA E kit) | 345 | 2D | AD | 3 | DeviceNet address | ✓ | ✓ | ✓ | — | | |
| | 346 | 2E | AE | 3 | DeviceNet baud rate | ✓ | ✓ | ✓ | — | | |
| Parameter for option FR-A7NC E kit FR-A7ND E kit FR-A7NL E kit FR-A7NP E kit | 349 | 31 | B1 | 3 | Communication reset selection | ✓ | ✓ | ✓ | — | | |
| LonWorks communication (FR-A7NLE E kit) | 387 | 57 | D7 | 3 | Initial communication delay time | ✓ | ✓ | ✓ | — | | |
| | 388 | 58 | D8 | 3 | Send time interval at heart beat | ✓ | ✓ | ✓ | | | |
| | 389 | 59 | D9 | 3 | Minimum sending time at heart beat | ✓ | ✓ | ✓ | | | |
| | 390 | 5A | DA | 3 | % setting reference frequency | ✓ | ✓ | ✓ | | | |
| | 391 | 5B | DB | 3 | Receive time interval at heart beat | ✓ | ✓ | ✓ | | | |
| | 392 | 5C | DC | 3 | Event driven detection width | ✓ | ✓ | ✓ | | | |
| Second applied motor | 450 | 32 | B2 | 3 | Second applied motor | ✓ | ✓ | ✓ | 6-85 | | |

Tab. A-5: Parameter list with instruction codes (8)

| Function | Parameter | Instruction Code | | | Name | Control Mode-based Correspondence Table | | | Refer to Page | Customer Setting |
|--|-----------|------------------|-------|----------|---|---|--|---------------------------------------|---------------|------------------|
| | | Read | Write | Extended | | V/f control | General-purpose magnetic flux vector control | Advanced magnetic flux vector control | | |
| Remote output | 495 | 5F | DF | 4 | Remote output selection | ✓ | ✓ | ✓ | 6-133 | |
| | 496 | 60 | E0 | 4 | Remote output data 1 | ✓ | ✓ | ✓ | | |
| | 497 | 61 | E1 | 4 | Remote output data 2 | ✓ | ✓ | ✓ | | |
| Parameter for option FR-A7NC E kit FR-A7ND E kit FR-A7NL E kit FR-A7NP E kit | 500 | 00 | 80 | 5 | Communication error execution waiting time | ✓ | ✓ | ✓ | — | |
| | 501 | 01 | 81 | 5 | Communication error occurrence count display | ✓ | ✓ | ✓ | | |
| | 502 | 02 | 82 | 5 | Stop mode selection at communication error | ✓ | ✓ | ✓ | | |
| Maintenance | 503 | 03 | 83 | 5 | Maintenance timer | ✓ | ✓ | ✓ | 6-300 | |
| | 504 | 04 | 84 | 5 | Maintenance timer alarm output set time | ✓ | ✓ | ✓ | | |
| CC-Link communication (FR-A7NC E kit) | 541 | 29 | A9 | 5 | Frequency command sign selection (CC-Link) | ✓ | ✓ | ✓ | — | |
| | 542 | 2A | AA | 5 | Communication station number (CC-Link) | ✓ | ✓ | ✓ | | |
| | 543 | 2B | AB | 5 | Baud rate (CC-Link) | ✓ | ✓ | ✓ | | |
| | 544 | 2C | AC | 5 | CC-Link extended setting | ✓ | ✓ | ✓ | | |
| USB | 547 | 2F | AD | 5 | USB communication station number | ✓ | ✓ | ✓ | 6-269 | |
| | 548 | 30 | B0 | 5 | USB communication check time interval | ✓ | ✓ | ✓ | | |
| Communication | 549 | 31 | B1 | 5 | Protocol selection | ✓ | ✓ | ✓ | 6-226 | |
| | 550 | 32 | B2 | 5 | NET mode operation command source selection | ✓ | ✓ | ✓ | 6-212 | |
| | 551 | 33 | B3 | 5 | PU mode operation command source selection | ✓ | ✓ | ✓ | | |
| Current average monitor | 555 | 37 | B7 | 5 | Current average time | ✓ | ✓ | ✓ | 6-301 | |
| | 556 | 38 | B8 | 5 | Data output mask time | ✓ | ✓ | ✓ | | |
| | 557 | 39 | B9 | 5 | Current average value monitor signal output reference current | ✓ | ✓ | ✓ | | |
| — | 563 | 3F | BF | 5 | Energizing time carrying-over times | ✓ | ✓ | ✓ | 6-138 | |
| — | 564 | 40 | C0 | 5 | Operating time carrying-over times | ✓ | ✓ | ✓ | | |
| — | 571 | 47 | C7 | 5 | Holding time at a start | ✓ | ✓ | ✓ | 6-73 | |
| — | 611 | 0B | 8B | 6 | Acceleration time at a restart | ✓ | ✓ | ✓ | 6-151 | |
| — | 645 | 2D | AD | 6 | AM 0V adjustment | ✓ | — | ✓ | 6-148 | |
| Reduce mechanical resonance | 653 | 35 | B5 | 6 | Speed smoothing control | ✓ | ✓ | ✓ | 6-173 | |
| — | 665 | 41 | C1 | 6 | Regeneration avoidance frequency gain | ✓ | ✓ | ✓ | 6-292 | |
| — | 800 | 00 | 80 | 8 | Control method selection | — | ✓ | ✓ | 6-36 | |
| — | 859 | 3B | BB | 8 | Torque current | — | ✓ | ✓ | 6-88 | |
| Protective function | 872 | 48 | C8 | 8 | Input phase loss protection selection | ✓ | ✓ | ✓ | 6-169 | |

Tab. A-5: Parameter list with instruction codes (9)

| Function | Parameter | Instruction Code | | | Name | Control Mode-based Correspondence Table | | | Refer to Page | Customer Setting |
|--|-----------------------|--|-------|----------|---|---|--|---------------------------------------|---------------|------------------|
| | | Read | Write | Extended | | V/f control | General-purpose magnetic flux vector control | Advanced magnetic flux vector control | | |
| Regeneration avoidance function | 882 | 52 | D2 | 8 | Regeneration avoidance operation selection | ✓ | ✓ | ✓ | 6-292 | |
| | 883 | 53 | D3 | 8 | Regeneration avoidance operation level | ✓ | ✓ | ✓ | | |
| | 885 | 55 | D5 | 8 | Regeneration avoidance compensation frequency limit value | ✓ | ✓ | ✓ | | |
| | 886 | 56 | D6 | 8 | Regeneration avoidance voltage gain | ✓ | ✓ | ✓ | | |
| Free parameter | 888 | 58 | D8 | 8 | Free parameter 1 | ✓ | ✓ | ✓ | 6-305 | |
| | 889 | 59 | D9 | 8 | Free parameter 2 | ✓ | ✓ | ✓ | | |
| Calibration parameters | C1 (901) | 5D | DD | 1 | AM terminal calibration | ✓ | ✓ | ✓ | 6-148 | |
| | C2 (902) | 5E | DE | 1 | Terminal 2 frequency setting bias frequency | ✓ | ✓ | ✓ | 6-180 | |
| | C3 (902) | 5E | DE | 1 | Terminal 2 frequency setting bias | ✓ | ✓ | ✓ | | |
| | 125 (903) | 5F | DF | 1 | Terminal 2 frequency setting gain frequency | ✓ | ✓ | ✓ | | |
| | C4 (903) | 5F | DF | 1 | Terminal 2 frequency setting gain | ✓ | ✓ | ✓ | | |
| | C5 (904) | 60 | E0 | 1 | Terminal 4 frequency setting bias frequency | ✓ | ✓ | ✓ | | |
| | C6 (904) | 60 | E0 | 1 | Terminal 4 frequency setting bias | ✓ | ✓ | ✓ | | |
| | 126 (905) | 61 | E1 | 1 | Terminal 4 frequency setting gain frequency | ✓ | ✓ | ✓ | | |
| | C7 (905) | 61 | E1 | 1 | Terminal 4 frequency setting gain | ✓ | ✓ | ✓ | | |
| — | C22 - C25 (922 - 923) | Parameter for manufacturer setting. Do not make setting. | | | | | | | | |
| PU | 990 | 5A | DA | 9 | PU buzzer control | ✓ | ✓ | ✓ | 6-309 | |
| | 991 | 5B | DB | 9 | PU contrast adjustment | ✓ | ✓ | ✓ | 6-309 | |
| Clear parameters/ Initial value change list | PR.CL | — | | | Parameter clear | — | — | — | 4-16 | |
| | ALLC | — | | | All parameter clear | — | — | — | 4-16 | |
| | Er.CL | — | | | Faults history clear | — | — | — | 7-18 | |
| | PR.CH | — | | | Initial value change list | — | — | — | 4-17 | |

Tab. A-5: Parameter list with instruction codes (10)

Index

A

| | |
|---------------------------------------|-------|
| AC reactor | 3-37 |
| Acceleration | |
| Characteristic | 6-75 |
| Acceleration and deceleration time | |
| Parameter | 6-69 |
| Accessory | 1-3 |
| Advanced magnetic flux vector control | 6-30 |
| Parameter | 6-36 |
| Alarm output | |
| Terminals | 3-16 |
| Auto tuning | 6-88 |
| Automatic restart | 6-151 |

B

| | |
|----------------|-------|
| Base frequency | 6-54 |
| Basic settings | 5-1 |
| Bias | |
| adjust | 6-180 |
| Buzzer | |
| control | 6-309 |

C

| | |
|------------------------------|-------|
| Cables | |
| Size | 3-9 |
| Calibration | |
| Terminal AM | 6-148 |
| Case | 1-2 |
| Characteristic | |
| Acceleration/deceleration | 6-75 |
| Load torque | 6-56 |
| Cleaning | 8-6 |
| Combined operation mode | 6-204 |
| Communication | |
| Basic settings | 6-226 |
| Mitsubishi inverter protocol | 6-233 |
| Modbus-RTU | 6-251 |
| PU connector | 6-221 |
| USB | 6-269 |
| Contactors and breakers | 3-3 |
| Contrast | |
| Parameter | 6-309 |
| Control codes | 6-237 |
| Control modes | 6-30 |
| Cooling | 2-10 |

| | |
|------------------------|-------|
| Cooling fan | |
| Operation | 6-295 |
| Reinstallation | 8-8 |
| Removal | 8-7 |
| Cooling system | 2-10 |
| Cumulative power meter | |
| clear | 6-138 |

D

| | |
|------------------------|-------|
| Dancer control | |
| Parameter | 6-282 |
| DC injection brake | |
| Parameter | 6-98 |
| DC reactor | 3-37 |
| Digital dial | |
| Description | 4-8 |
| Magnitude | 6-308 |
| Dimensions | |
| Inverter | A-5 |
| Parameter unit FR-PA07 | A-10 |
| Parameter unit FR-PU07 | A-9 |
| Display | |
| I/O terminals | 6-143 |
| Selection | 6-138 |
| Speed | 6-136 |
| Droop control | 6-291 |

E

| | |
|-------------------------------|-------|
| Earthing | |
| Leakage currents | 3-11 |
| Electromagnetic compatibility | 3-38 |
| Enclosure | |
| Cooling system | 2-10 |
| Design | 2-7 |
| Energy saving operation | 6-171 |
| Environment specifications | 2-7 |
| Error | |
| corrective action | 7-4 |
| Diagnosis | 7-1 |
| Display | 7-4 |
| LED/LCD display | 7-2 |
| List | 7-2 |
| Message | 7-2 |
| Troubleshooting | 7-20 |

| F | |
|----------------------|-------|
| Fault history | |
| clear | 7-18 |
| read | 7-18 |
| Frequency jump | |
| Parameter | 6-52 |
| Frequency monitor | |
| Reference | 6-146 |
| Frequency setting | |
| Digital dial | 5-23 |
| Front cover | |
| Reinstallation | 2-1 |
| Removal | 2-1 |

| G | |
|--------------|-------|
| Gain | |
| adjust | 6-180 |

| I | |
|----------------------------------|-------|
| Input terminals | |
| Function selection | 6-114 |
| Inspection | 8-1 |
| Installation | |
| Enclosure | 2-6 |
| Instruction codes | A-11 |
| Insulation resistance test | 8-11 |

| J | |
|-----------------|------|
| Jog operation | |
| Parameter | 6-61 |

| L | |
|------------------------|-------|
| Language | |
| Selection | 6-306 |
| Language selection | |
| Parameter | 6-306 |
| Leakage currents | 3-38 |
| Life | |
| Monitor | 6-296 |
| Load pattern | |
| Selection | 6-56 |
| Logic | |
| Sink logic | 3-20 |
| Source logic | 3-20 |

| M | |
|------------------------------------|-------|
| Maintenance | 8-1 |
| Maintenance timer | |
| Parameter | 6-300 |
| Mechanical brake | |
| Control | 6-109 |
| Mitsubishi inverter protocol | 6-233 |
| Mode | |
| external Operation | 5-30 |
| PU operation | 5-20 |
| Motor | |
| Selection | 6-85 |
| Motor protection | |
| Parameter | 6-80 |
| Multi-speed setting | |
| Parameter | 6-58 |

| O | |
|---------------------------|-------|
| Operation hour meter | |
| clear | 6-138 |
| Operation mode | |
| at power on | 6-210 |
| combined | 6-204 |
| Communication | 6-215 |
| external operation | 6-202 |
| PU operation mode | 6-203 |
| Operation mode selection | |
| Flow chart | 6-201 |
| Parameter | 6-198 |
| Operation panel | |
| Basic functions | 4-9 |
| Functions | 4-7 |
| Output | |
| analog | 6-146 |
| Output current | |
| Detection | 6-131 |
| Output frequency | |
| Detection | 6-129 |
| Frequency jumps | 6-52 |
| Jog frequency | 6-61 |
| maximum | 6-50 |
| minimum | 6-50 |
| Multi-speed setting | 6-58 |
| Starting frequency | 6-73 |
| Output terminals | |
| Function selection | 6-124 |

| P | | S | |
|-----------------------------|-------|------------------------------------|-------|
| Parameter | | Second functions | |
| clear | 4-16 | Setting | 6-119 |
| free | 6-305 | Set value | |
| Instruction codes | A-11 | adjust | 6-180 |
| Overview | 6-1 | analog | 6-174 |
| set | 4-15 | Bias | 6-184 |
| Simple mode parameters | 5-1 | Filter | 6-179 |
| Parameter unit | | Gain | 6-184 |
| Wiring | 3-23 | Shortest acceleration/deceleration | 6-77 |
| Parameter write disable | 6-192 | Specifications | A-1 |
| PID control | | Speed display | |
| Parameter | 6-270 | Parameter | 6-136 |
| PLC | | Stall prevention | |
| Connection | 3-22 | Parameter | 6-42 |
| Power failure | | Stall prevention operation | 6-42 |
| Automatic restart | 6-151 | Start signal | |
| Protective earth | | Assignment | 6-120 |
| Wiring | 3-6 | Starting frequency | |
| Protective functions | | DC injection brake | 6-98 |
| Overview | A-4 | Parameter | 6-73 |
| reset | 7-16 | Starting the inverter | 4-6 |
| | | Station number | 6-226 |
| | | Stop-on contact | 6-105 |
| | | Switch | |
| | | Voltage/current | 6-175 |
| R | | T | |
| Reactor | 3-37 | Terminal | |
| Regeneration avoidance | | Control circuit | 3-14 |
| Parameter | 6-292 | Terminals | |
| Remote outputs | | Communication | 3-16 |
| Parameter | 6-133 | Function assignment | 6-114 |
| Remote setting function | | Torque | |
| Parameter | 6-65 | Boost | 6-33 |
| Reset | 7-16 | Parameter | 6-33 |
| Resonance points | | | |
| Avoidance | 6-52 | U | |
| Restart | | Up-to-frequency sensivity | |
| at alarm occurrence | 6-166 | Parameter | 6-129 |
| at power failure | 6-153 | USB connector | 6-269 |
| Reverse rotation prevention | | User group | |
| Parameter | 6-194 | Parameter deletion | 6-197 |
| | | User groups | |
| | | Parameter | 6-195 |

V

| | |
|-------------------|------|
| V/f control | 6-30 |
| V/f pattern | |
| Parameter | 6-54 |
| Vector control | |
| Parameter | 6-39 |

W

| | |
|---|------|
| Wiring | |
| Control circuit | 3-14 |
| DC reactor | 3-37 |
| external brake unit | 3-32 |
| High power factor converter | 3-35 |
| Magnetic contactor | 3-26 |
| Main circuit | 3-6 |
| Parameter unit | 3-23 |
| Power regeneration common converter ... | 3-36 |
| Reactor | 3-37 |
| stand-alone option units | 3-26 |
| System configuration | 3-1 |
| Terminal connection diagram | 3-4 |

Z

| | |
|-----------------|-------|
| Zero current | |
| Detection | 6-132 |

HEADQUARTERS

MITSUBISHI ELECTRIC EUROPE B.V. **EUROPE**
 German Branch
 Gothaer Straße 8
D-40880 Ratingen
 Phone: +49 (0)2102 / 486-0
 Fax: +49 (0)2102 / 486-1120

MITSUBISHI ELECTRIC EUROPE B.V.-org.sl. **CZECH REP.**
 Czech Branch
 Avenir Business Park, Radlická 714/113a
CZ-158 00 Praha 5
 Phone: +420 - 251 551 470
 Fax: +420 - 251-551-471

MITSUBISHI ELECTRIC EUROPE B.V. **FRANCE**
 French Branch
 25, Boulevard des Bouvets
F-92741 Nanterre Cedex
 Phone: +33 (0)1 / 55 68 55 68
 Fax: +33 (0)1 / 55 68 57 57

MITSUBISHI ELECTRIC EUROPE B.V. **IRELAND**
 Irish Branch
 Westgate Business Park, Ballymount
IRL-Dublin 24
 Phone: +353 (0)1 4198800
 Fax: +353 (0)1 4198890

MITSUBISHI ELECTRIC EUROPE B.V. **ITALY**
 Italian Branch
 Viale Colleoni 7
I-20041 Agrate Brianza (MB)
 Phone: +39 039 / 60 53 1
 Fax: +39 039 / 60 53 312

MITSUBISHI ELECTRIC EUROPE B.V. **POLAND**
 Poland Branch
 Krakowska 50
PL-32-083 Balice
 Phone: +48 (0)12 / 630 47 00
 Fax: +48 (0)12 / 630 47 01

MITSUBISHI ELECTRIC EUROPE B.V. **RUSSIA**
 52, bid. 3 Kosmodamianskaya nab 8 floor
RU-115054 Moscow
 Phone: +7 495 721-2070
 Fax: +7 495 721-2071

MITSUBISHI ELECTRIC EUROPE B.V. **SPAIN**
 Spanish Branch
 Carretera de Rubí 76-80
E-08190 Sant Cugat del Vallés (Barcelona)
 Phone: 902 131121 // +34 935653131
 Fax: +34 935891579

MITSUBISHI ELECTRIC EUROPE B.V. **UK**
 UK Branch
 Travellers Lane
UK-Hatfield, Herts. AL10 8XB
 Phone: +44 (0)1707 / 27 61 00
 Fax: +44 (0)1707 / 27 86 95

MITSUBISHI ELECTRIC CORPORATION **JAPAN**
 Office Tower "Z" 14 F
 8-12,1 chome, Harumi Chuo-Ku
Tokyo 104-6212
 Phone: +81 3 622 160 60
 Fax: +81 3 622 160 75

MITSUBISHI ELECTRIC AUTOMATION, Inc. **USA**
 500 Corporate Woods Parkway
Vernon Hills, IL 60061
 Phone: +1 847 478 21 00
 Fax: +1 847 478 22 53

EUROPEAN REPRESENTATIVES

GEVA **AUSTRIA**
 Wiener Straße 89
AT-2500 Baden
 Phone: +43 (0)2252 / 85 55 20
 Fax: +43 (0)2252 / 488 60

TEHNIKON **BELARUS**
 Oktyabrskaya 16/5, Off. 703-711
BY-220030 Minsk
 Phone: +375 (0)17 / 210 46 26
 Fax: +375 (0)17 / 210 46 26

ESCO DRIVES & AUTOMATION **BELGIUM**
 Culliganlaan 3
BE-1831 Diegem
 Phone: +32 (0)2 / 717 64 30
 Fax: +32 (0)2 / 717 64 31

Koning & Hartman b.v. **BELGIUM**
 Woluwelaan 31
BE-1800 Vilvoorde
 Phone: +32 (0)2 / 257 02 40
 Fax: +32 (0)2 / 257 02 49

INEA BH d.o.o. **BOSNIA AND HERZEGOVINA**
 Aleja Lipa 56
BA-71000 Sarajevo
 Phone: +387 (0)33 / 921 164
 Fax: +387 (0)33 / 524 539

AKHNATON **BULGARIA**
 4 Andrej Ljapchev Blvd. Pb 21
BG-1756 Sofia
 Phone: +359 (0)2 / 817 6044
 Fax: +359 (0)2 / 97 44 06 1

INEA CR d.o.o. **CROATIA**
 Losinjska 4 a
HR-10000 Zagreb
 Phone: +385 (0)1 / 36 940 - 01 / -02 / -03
 Fax: +385 (0)1 / 36 940 - 03

AutoCont C.S. s.r.o. **CZECH REPUBLIC**
 Technologická 374/6
CZ-708 00 Ostrava-Pustkovce
 Phone: +420 595 691 150
 Fax: +420 595 691 199

Beijer Electronics A/S **DENMARK**
 Lykkegårdsvej 17
DK-4000 Roskilde
 Phone: +45 (0)46 / 75 76 66
 Fax: +45 (0)46 / 75 56 26

Beijer Electronics Eesti OÜ **ESTONIA**
 Pärnu mnt.160i
EE-11317 Tallinn
 Phone: +372 (0)6 / 51 81 40
 Fax: +372 (0)6 / 51 81 49

Beijer Electronics OY **FINLAND**
 Peltoie 37
FIN-28400 Ulvila
 Phone: +358 (0)207 / 463 540
 Fax: +358 (0)207 / 463 541

UTEKO **GREECE**
 5, Mavrogenou Str.
GR-18542 Piraeus
 Phone: +30 211 / 1206 900
 Fax: +30 211 / 1206 999

MELTRADE Kft. **HUNGARY**
 Fertő utca 14.
HU-1107 Budapest
 Phone: +36 (0)1 / 431-9726
 Fax: +36 (0)1 / 431-9727

Beijer Electronics SIA **LATVIA**
 Rītausmas iela 23
LV-1058 Rīga
 Phone: +371 (0)784 / 2280
 Fax: +371 (0)784 / 2281

Beijer Electronics UAB **LITHUANIA**
 Savanorių Pr. 187
LT-02300 Vilnius
 Phone: +370 (0)5 / 232 3101
 Fax: +370 (0)5 / 232 2980

EUROPEAN REPRESENTATIVES

ALFATRADE Ltd. **MALTA**
 99, Paola Hill
Malta- Paola PLA 1702
 Phone: +356 (0)21 / 697 816
 Fax: +356 (0)21 / 697 817

INTEHSIS srl **MOLDOVA**
 bld. Traian 23/1
MD-2060 Kishinev
 Phone: +373 (0)22 / 66 4242
 Fax: +373 (0)22 / 66 4280

HIFLEX AUTOM.TECHNIEK B.V. **NETHERLANDS**
 Wolveverstraat 22
NL-2984 CD Ridderkerk
 Phone: +31 (0)180 - 46 60 04
 Fax: +31 (0)180 - 44 23 55

Koning & Hartman b.v. **NETHERLANDS**
 Haarlbergweg 21-23
NL-1101 CH Amsterdam
 Phone: +31 (0)20 / 587 76 00
 Fax: +31 (0)20 / 587 76 05

Beijer Electronics AS **NORWAY**
 Postboks 487
NO-3002 Drammen
 Phone: +47 (0)32 / 24 30 00
 Fax: +47 (0)32 / 84 85 77

Fonseca S.A. **PORTUGAL**
 R. João Francisco do Casal 87/89
PT - 3801-997 Aveiro, Esgueira
 Phone: +351 (0)234 / 303 900
 Fax: +351 (0)234 / 303 910

Sirius Trading & Services srl **ROMANIA**
 Aleea Lacul Morii Nr. 3
RO-060841 Bucuresti, Sector 6
 Phone: +40 (0)21 / 430 40 06
 Fax: +40 (0)21 / 430 40 02

Craft Con. & Engineering d.o.o. **SERBIA**
 Bulevar Svetog Cara Konstantina 80-86
SER-18106 Nis
 Phone: +381 (0)18 / 292-24-4/5
 Fax: +381 (0)18 / 292-24-4/5

INEA SR d.o.o. **SERBIA**
 Izletnicka 10
SER-113000 Smederevo
 Phone: +381 (0)26 / 617 163
 Fax: +381 (0)26 / 617 163

SIMAP s.r.o. **SLOVAKIA**
 Jána Derku 1671
SK-911 01 Trenčín
 Phone: +421 (0)32 743 04 72
 Fax: +421 (0)32 743 75 20

PROCONT, spol. s r.o. Prešov **SLOVAKIA**
 Kúpeľná 1/A
SK-080 01 Prešov
 Phone: +421 (0)51 7580 611
 Fax: +421 (0)51 7580 650

INEA d.o.o. **SLOVENIA**
 Stegne 11
SI-1000 Ljubljana
 Phone: +386 (0)1 / 513 8100
 Fax: +386 (0)1 / 513 8170

Beijer Electronics AB **SWEDEN**
 Box 426
SE-20124 Malmö
 Phone: +46 (0)40 / 35 86 00
 Fax: +46 (0)40 / 93 23 01

Omni Ray AG **SWITZERLAND**
 Im Schörlif 5
CH-8600 Dübendorf
 Phone: +41 (0)44 / 802 28 80
 Fax: +41 (0)44 / 802 28 28

GTS **TURKEY**
 Bayraktar Bulvarı Nutuk Sok. No:5
TR-34775 Yukarı Dudullu-Ümraniye-İSTANBUL
 Phone: +90 (0)216 526 39 90
 Fax: +90 (0)216 526 39 95

CSC Automation Ltd. **UKRAINE**
 4-B, M. Raskovoyi St.
UA-02660 Kiev
 Phone: +380 (0)44 / 494 33 55
 Fax: +380 (0)44 / 494-33-66

EURASIAN REPRESENTATIVES

Kazpromautomatiks Ltd. **KAZAKHSTAN**
 Mustafina Str. 7/2
KAZ-470046 Karaganda
 Phone: +7 7212 / 50 11 50
 Fax: +7 7212 / 50 11 50

MIDDLE EAST REPRESENTATIVE

SHERF Motion Techn. Ltd. **ISRAEL**
 Rehov Hamerkava 19
IL-58851 Holon
 Phone: +972 (0)3 / 559 54 62
 Fax: +972 (0)3 / 556 01 82

CEG INTERNATIONAL **LEBANON**
 Cebaco Center/Block A Autostrade DORA
Lebanon - Beirut
 Phone: +961 (0)1 / 240 430
 Fax: +961 (0)1 / 240 438

AFRICAN REPRESENTATIVE

CBI Ltd. **SOUTH AFRICA**
 Private Bag 2016
ZA-1600 Isando
 Phone: +27 (0)11 / 977 0770
 Fax: +27 (0)11 / 977 0761